

Copyright © 2009, Forel Publishing Company, LLC, Woodbridge, Virginia

All Rights Reserved. No part of this book may be used or reproduced in any manner whatsoever without written permission of Forel Publishing Company, LLC. For information write to Forel Publishing Company, LLC, 3999 Peregrine Ridge Ct., Woodbridge, VA 22192

1965 Mustang Part and Body Illustrations
EAN: 978-1-60371-033-6
ISBN: 1-60371-033-7

Forel Publishing Company, LLC
3999 Peregrine Ridge Ct.
Woodbridge, VA 22192
Email address: webmaster@ForelPublishing.com
Website: <http://www.ForelPublishing.com>



This publication contains material that is reproduced and distributed under a license from Ford Motor Company. No further reproduction or distribution of the Ford Motor Company material is allowed without the express written permission of Ford Motor Company.

Note from the Editor

This product was compiled using original Ford Motor Company publications. The contents of this product were extracted from: 1965/72 Ford Car Master Parts and Accessory Catalog (FP-7635- A and FP-7635- B).

Disclaimer

Although every effort was made to ensure the accuracy of this book, no representations or warranties of any kind are made concerning the accuracy, completeness or suitability of the information, either expressed or implied. As a result, the information contained within this book should be used as general information only. The author and Forel Publishing Company, LLC shall have neither liability nor responsibility to any person or entity with respect to any loss or damage caused, or alleged to be caused, directly or indirectly by the information contained in this book. Further, the publisher and author are not engaged in rendering legal or other professional services. If legal, mechanical, electrical, or other expert assistance is required, the services of a competent professional should be sought.

Navigating with bookmarks

This manual is primarily organized using “bookmarks”. Bookmarks are found on the left side of the screen and allow the user to navigate directly to a specific location within the document.

To browse using a bookmark:

1. Click the Bookmarks tab on the left side of the window, or choose view>Navigation Tabs>Bookmarks to display bookmarks.
2. To jump to a topic using its bookmark, click the bookmark. Click the plus sign (+) next to a parent bookmark to expand it. Click the minus sign (-) next to a bookmark to hide its children.

Note: Clicking a bookmark might perform an action instead of taking you to another location. It depends on how the bookmark was defined. For example, a hyperlinked bookmark could take you to a website.

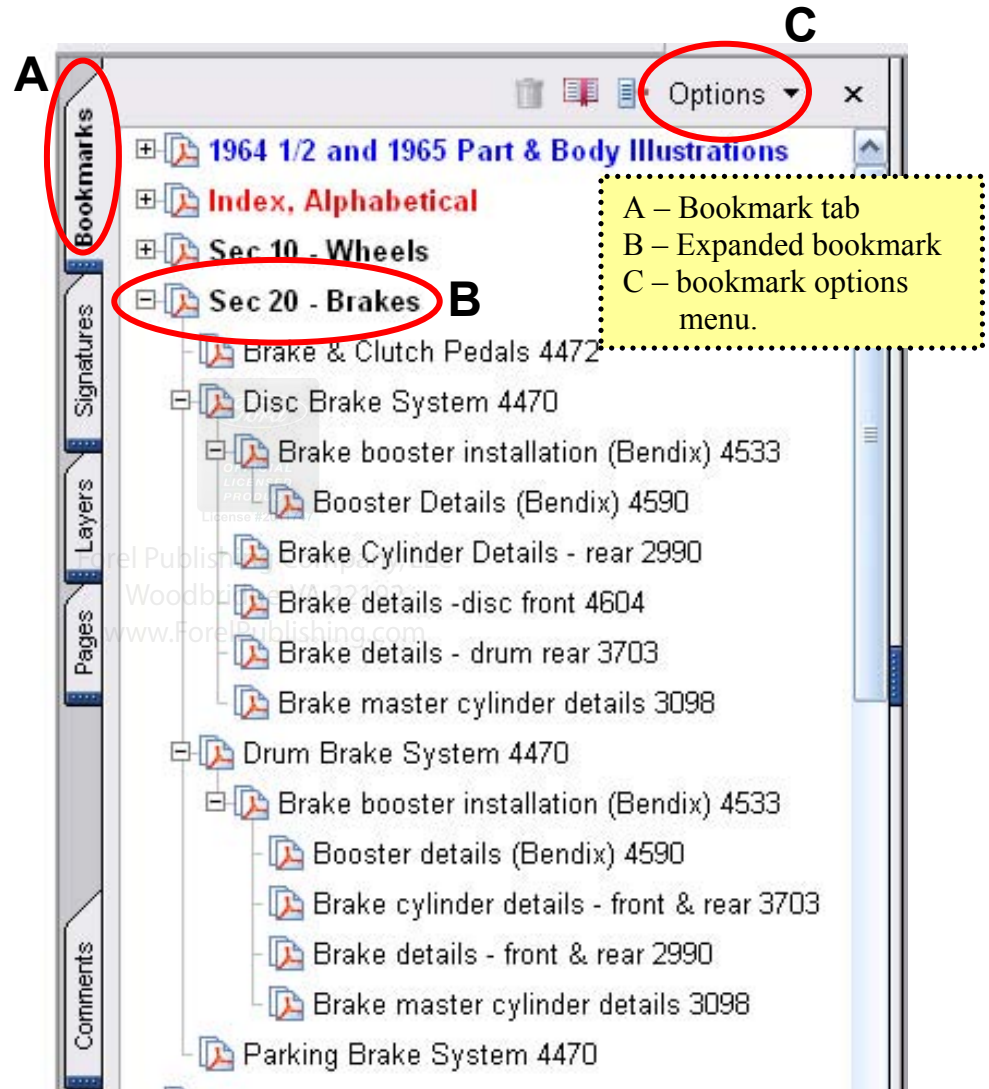

If the list of bookmarks disappears when you click a bookmark, click the Bookmarks tab to display the list again. If you want the Bookmarks tab to always remain open after you click a bookmark, click the Options menu at the top of the Bookmarks panel, and make sure Hide After Use is not selected.

Basic Manual Organization

This manual is organized in three ways: **Illustration Number, Groupings by Sections** and **Alphabetical**.

Illustration Number:

Each illustration has its own illustration number. For example, the illustration for Brake & Clutch Pedals is illustration number “P-4472” and the illustration for the Brake Cylinder Details is “P-2990”. The pages of this book are arranged in illustration number order. Therefore, illustration 4473 would follow 2990.

Note: Illustrations are in numerical, not alphabetical order.

Groupings by Sections:

The grouping of diagrams by “section” is similar to how the Ford Motor Company originally organized its Master Parts and Accessories Catalog which contained both illustrations and part numbers to identify parts. For example, **Section 20 – Brakes** groups most brake related parts for this vehicle.

This manual uses bookmarks to follow that same organization and uses the same terms Ford used to identify the diagrams. In addition, the diagram number has been added to the end of the description. For example, **“Disc Brake System 4470”** is the basic name of the diagram and the diagram number is 4470. For the bookmarks and index’s in this manual, the “P-“ has been omitted.

Sec 20 - Brakes

Brake & Clutch Pedals 4472
Disc Brake System 4470
 Brake booster installation (Bendix) 4533
 Booster Details (Bendix) 4590
Brake Cylinder Details - rear 2990
Brake details -disc front 4604
Brake details - drum rear 3703
Brake master cylinder details 3098
Drum Brake System 4470
 Brake booster installation (Bendix) 4533
 Booster details (Bendix) 4590
 Brake cylinder details - front & rear 2990
 Brake details - front & rear 2990
 Brake master cylinder details 3098
Parking Brake System 4470

The grouping of diagrams by number is useful in finding most diagrams related to a major group.

Alphabetical:

The alphabetical listing is a simple alphabetized listing of all diagrams. In some cases, if the diagram contained more than one major component, the diagram may be identified more than once. Expand the “Index, Alphabetical” bookmark to view details. The associated page contains the description, diagram number and page number for easy reference.

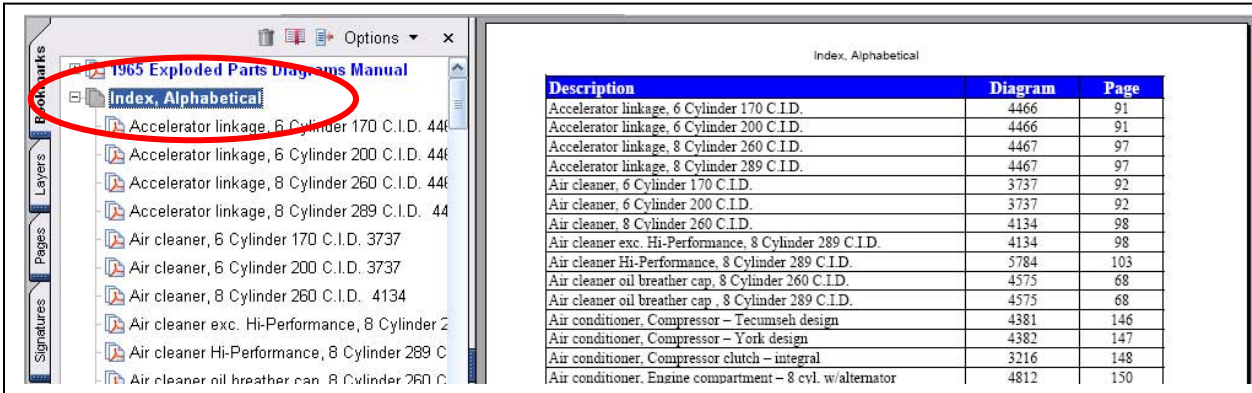

Index, Alphabetical

Description	Diagram	Page
Accelerator linkage, 6 Cylinder 170 C.I.D.	4466	91
Accelerator linkage, 6 Cylinder 200 C.I.D.	4466	91
Accelerator linkage, 8 Cylinder 260 C.I.D.	4467	97
Accelerator linkage, 8 Cylinder 289 C.I.D.	4467	97
Air cleaner, 6 Cylinder 170 C.I.D.	3737	92
Air cleaner, 6 Cylinder 200 C.I.D.	3737	92
Air cleaner, 8 Cylinder 260 C.I.D.	4134	98
Air cleaner exc. Hi-Performance, 8 Cylinder 289 C.I.D.	4134	98
Air cleaner Hi-Performance, 8 Cylinder 289 C.I.D.	5784	103
Air cleaner oil breather cap, 8 Cylinder 260 C.I.D.	4575	68
Air cleaner oil breather cap, 8 Cylinder 289 C.I.D.	4575	68
Air conditioner, Compressor - Tecumseh design	4381	146
Air conditioner, Compressor - York design	4382	147
Air conditioner, Compressor clutch - integral	3216	148
Air conditioner, Engine compartment - 8 cyl. w/alternator	4812	150

Note: Illustrations are in numerical, not alphabetical order.

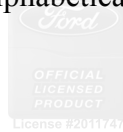

Forel Publishing Company, LLC
Woodbridge, VA 22192
www.ForelPublishing.com

Index, Numerical Order
1965 Mustang Part and Body Illustrations

Diagram	Description	Page
1246	Oil filters - cartridge type	18
1535	Voltage Regulator – typical (Generator)	19
2130	Rear Axle Non-Locking (separate carrier)	20
2384	Oil filters - spin-on type	21
2819	Rear Axle Locking - Equa Lock (separate carrier)	22
2926	Distributor (8 cylinder - Pivot Plate type-exc. With stamped weights)	23
2961	Distributor (6 cylinder 200 engines)	24
2962	Water Pumps, 6 cyl. - 200, 250 engines	25
2963	Oil pump, 6 Cylinder 200, 250 C.I.D.	26
2964	Camshaft, gear and bearings, 6 Cylinder 200, 250 C.I.D.	27
2965	Crankshaft and flywheel, 6 Cylinder 170 C.I.D.	28
2966	Transmission, Manual, 3 Speed manual trans 2.77 type	29
2990	Brake cylinder details - front & rear	30
3088	Cylinder block, 6 Cylinder 200, 250 C.I.D.	31
3089	Valves, push rods and rocker arm cover, 6 Cylinder	32
3090	Piston and connecting rod, 6 Cylinder 200, 250 C.I.D.	33
3098	Brake master cylinder details	34
3118	Front and rear wheel, hub, & bearing	35
3120	Front Suspension	36
3121	Steering Linkage - 6 cyl.	37
3122	Steering Gear Details	38
3125	Springs	39
3129	Shock absorber - front	40
3137	Shock absorber - rear	41
3144	Drive Shaft	42
3147	Cooling Systems, 6 & 8 Cyl. Engines	43
3191	Starter and Drive Assy. – Positive Engagement	44
3192	Generator and Related Parts (Ford 15 volt – 25, 30 amp)	45
3216	Air conditioner, Compressor clutch (integral)	46
3446	Interior trim parts, folding top compartment trim	47
3475	Distributor (6 cylinder 240 engines)	48
3627	Transmission Automatic, Vacuum throttle valve, lines and fittings - typical	49

Index, Numerical Order
1965 Mustang Part and Body Illustrations

Diagram	Description	Page
3703	Brake details - drum rear	50
3715	Fuel pump, 8 Cylinder 260/289 C.I.D.	51
3726	Valves, push rods and rocker arm cover, 6 Cyl and 8 Cyl 260,	52
3727	Cylinder head, valves, and related parts, 8 Cyl.	53
3732	Piston and connecting rod, 6 Cyl and 8 Cyl 260, 289,302,351,400,429,460 C.I.D.	54
3733	Camshaft, gear and bearings, 8 Cylinder 289 C.I.D.	55
3734	Crankshaft and flywheel, 8 Cylinder 289 C.I.D.	56
3736	Oil pump, 8 Cylinder 260, 289,302,351,400,429,460 C.I.D.	57
3737	Air cleaner, 6 Cylinder 200 C.I.D.	58
3742	Intake manifold & related parts, 8 Cylinder 289 CID Engine	59
3744	Transmission, Manual, Warner 4 speed less forks, 1	60
3745	Transmission, Manual, Warner 4 speed forks, levers	61
3767	Cylinder block and cylinder head, 8 Cylinder 289 C	62
3772	Water Pumps, 8 cyl. - 260, 289 engines (without cover)	63
3843	Alternator (Leece Neville 15 volt-60, 65 amp)	64
3849	Alternator (Leece Neville 15 volt-40, 53 amp)	65
3903	Transmission, Manual, Dagenham 4 speed less forks,	66
3904	Transmission, Manual, Dagenham 4 speed forks, lever	67
4012	Transmission, Manual, 3 Speed manual trans 3.03 type	68
4020	Ventilating ducts	69
4134	Air cleaner exc. Hi-Performance, 8 Cylinder	70
4139	Steering Linkage - 6 & 8 cyl. with Eaton pump	71
4146	Intake manifold type-open system, 8 Cylinder 289 C	72
4148	Transmission Oil cooling system, automatic - typical	73
4180	Cylinder Details	74
4200	Wiper motor (2 speed Ford electric)	75
4326	Transmission C4 Type, Case, converter assy., extension, pump - typical	76
4327	Transmission C4 Type, Clutches, gears, shafts, rear support - typical	77
4328	Transmission C4 Type, Servo and band, front - typical	78
4329	Transmission C4 Type, Servo and band, rear - typical	79
4330	Transmission C4 Type, Parking pawl, throttle and manual control linkage - typical	80
4367	Fuel pump, 6 Cylinder 200 C.I.D.	81

Index, Numerical Order
1965 Mustang Part and Body Illustrations

Diagram	Description	Page
4381	Air conditioner, Compressor (Tecumseh design)	82
4382	Air conditioner, Compressor (York design)	83
4389	Rocker arm cover type-open system, 6 Cylinder 200	84
4424	Transmission, Manual, Ford 4 speed	85
4455	Front seats – bucket - body types 63A, 65, and 76A	86
4456	Interior trim parts (Two door hardtop formal roof)	87
4457	Interior trim parts (Convertible)	88
4458	Radiator Grille and Related Parts	89
4459	Battery Carrier and Related Parts	90
4460	Headlamp	91
4461	Parking Lamp	92
4462	Hood	93
4463	Rear lamp, back up & license plate	94
4464	Bumper, Front	95
4465	Bumper, Rear	96
4466	Accelerator linkage, 6 Cylinder 170, 200 C.I.D. Engines	97
4467	Accelerator linkage, 8 Cylinder 280, 289 C.I.D. Engines	98
4470	Brake System, Disc/Drum	99
4472	Brake & Clutch Pedals	100
4476	Back window – body type 65	101
4477	Latch parts – body type 65, 70 (luggage compartment)	102
4478	Roof side mouldings and weatherstrips – body type 65	103
4479	Folding top parts – less trim – body type 76	104
4483	Steering Linkage - 8 cyl.	105
4486	Sheet Metal, Two door hardtop fastback/formal roof	106
4487	Sheet Metal, Convertible - Under body	107
4488	Sheet Metal, Two door hardtop formal roof - Upper	108
4489	Sheet Metal, Convertible - Upper body	109
4490	Exterior Moulding, All,	110
4491	Windshield – body types 63, 65	111
4492	Windshield – body type 76	112
4493	Console – without A/C	113
4494	Window parts (front door) 4494	114

Index, Numerical Order
1965 Mustang Part and Body Illustrations

Diagram	Description	Page
4495	Handles and latch parts (front door)	115
4496	Window parts (quarter) – body types 65, 76	116
4498	Wiring System	117
4499	Fuel System	118
4500	Engine Supports	119
4501	Transmission Automatic, Shift control selector mechanism, Automatic	120
4507	Transmission C4 Type, Main control valve body assy. (Basic 7A100) - typical	121
4508	Alternator (Ford 15 volt-38, 42, 45, 55, 60 amp)	122
4514	Horn Ring, Steering Wheel and related parts – non-woodgrain wheel	123
4516	Transmission, Manual, 3 speed trans, Gear shift mechanism - console or floor mtd	124
4524	Windshield Wiper	125
4525	Washer, windshield	126
4526	Carburetor – Ford 2V, 8 Cylinder 289 C.I.D.	127
4527	Carburetor – Ford 4V, 8 Cylinder 289 C.I.D.	128
4533	Brake booster installation (Bendix)	129
4540	Heater	130
4543	Mirror – remote control	131
4548	Convertible top, wiring	132
4549	Air conditioner, Passenger compartment – hang-on	133
4573	Air conditioner, Engine compartment – hang-on 6 cy	134
4574	Pump Details - Ford Type	135
4575	Air cleaner oil breather cap , Closed System	136
4590	Booster Details (Bendix)	137
4592	Emission Reduction System, rocker arm cover type-open system	138
4596	Jack and spare wheel parts	139
4602	Console – with A/C	140
4604	Brake details -disc front	141
4605	Power Steering System - 8 cyl.	142
4606	Power Steering System - 6 cyl.	143
4640	Sheet Metal, Two door hardtop fastback roof - Uppe	144
4728	Carburetor – Ford Type, 6 Cylinder 200 C.I.D.	145
4734	Courtesy lamp – instrument panel mounted	146

Index, Numerical Order
1965 Mustang Part and Body Illustrations

Diagram	Description	Page
4735	Courtesy lamp – quarter panel mounted	147
4764	Rear seat – folding – body type 63	148
4767	Interior trim parts (Two door hardtop fastback roof)	149
4795	Air extractor parts (quarter) – body type 63	150
4812	Air conditioner, Engine compartment (8 cyl. w/alt)	151
4838	Roof side mouldings and weatherstrips – body type 63	152
4839	Back window – body type 63	153
4844	Latch parts – body type 63 (luggage compartment)	154
4862	Transmission Automatic, bushings	155
4863	Luggage and ski carrier – non adjustable – roof mounted	156
4885	Front seat – full width	157
4889	Fog, lights	158
4899	Crankshaft and flywheel, 6 Cylinder 200, 250 C.I.D.	159
4921	Emergency Warning Flasher	160
4924	Distributor (8 cylinder – with stamped weights)	161
4926	Courtesy lamp – Door mounted	162
4940	Thermostatic choke control - except Hi-Performance	163
4955	Steering Wheel, 3 Spoke – woodgrain wheel	164
5143	Water Pumps, 8 cyl. - 289, 302, 351W engine (with cover)	165
5376	Wiper motor (single speed Ford electric)	166
5525	Voltage Regulator (Ford 15 volt, negative ground)	167
5526	Starter Drive (Ford 12 volt – positive engagement)	168
5741	Alternator (Leece Neville 15 volt-53, 60, 65 amp)	169
5784	Air cleaner Hi-Performance, 8 Cylinder 289 C.I.D.	170
5796	Rear Axle Equa Lock (integral carrier) and Non-Locking (integral carrier)	171
5810	Transmission, Manual, Ford 4 speed, Gear shift mechanism - console or floor mtd	172
6366	Steering column - floor shift	173
6980	Hinges - front door upper	174
6981	Hinges – front door lower	175
7453	Control Valve Details - 8 cyl.	176
7454	Control Valve Details - 6 cyl.	177
7460	Carburetor – Holley Type, 6 Cylinder 200 C.I.D.	178

Index, Numerical Order
1965 Mustang Part and Body Illustrations

Diagram	Description	Page
8393	Engine assembly, 8 Cylinder 260 C.I.D.	179
8396	Engine assembly, 8 Cylinder 289 C.I.D.	180
8398	Engine assembly, 6 Cylinder 200, 250 C.I.D.	181
8408	Rocker arm cover type-closed system, 6 Cylinder 200, 250	182
8972	Instrument panel and pad – w/gauges	183
8973	Instrument Cluster and Related Parts – w/Gauges	184
8984	Instrument panel and pad – w/indicator lights	185
8985	Instrument Cluster and Related Parts – w/Warning Lights	186
9205	Fender and apron sheet metal	187
9579	Pump Details - Eaton Type	188
10675	Auxiliary air spring installation	189
11536	Child safety seat	190
EA-21	Exhaust System, Regular Fuel, Single Exhaust	191
EA-22	Exhaust System, Single Exhaust	192
EA-27	Exhaust System, Regular Fuel, GT, Shelby, dual Exhaust from 10/15/64	193
EA-28	Exhaust System, Transverse, Before 10/15/64	194
EA-45	Exhaust System, In-line, Before 10/15/64	195

Index, Alphabetical Order
1965 Mustang Part and Body Illustrations

Description	Diagram	Page
Accelerator linkage, 6 Cylinder 170, 200 C.I.D. Engines	4466	97
Accelerator linkage, 8 Cylinder 280, 289 C.I.D. Engines	4467	98
Air cleaner exc. Hi-Performance, 8 Cylinder	4134	70
Air cleaner Hi-Performance, 8 Cylinder 289 C.I.D.	5784	170
Air cleaner oil breather cap , Closed System	4575	136
Air cleaner, 6 Cylinder 200 C.I.D.	3737	58
Air conditioner, Compressor (York design)	4382	83
Air conditioner, Compressor (Tecumseh design)	4381	82
Air conditioner, Compressor clutch (integral)	3216	46
Air conditioner, Engine compartment – hang-on 6 cy	4573	134
Air conditioner, Engine compartment (8 cyl. w/alt)	4812	151
Air conditioner, Passenger compartment – hang-on	4549	133
Air extractor parts (quarter) – body type 63	4795	150
Alternator (Ford 15 volt-38, 42, 45, 55, 60 amp)	4508	122
Alternator (Leece Neville 15 volt-40, 53 amp)	3849	65
Alternator (Leece Neville 15 volt-53, 60, 65 amp)	5741	169
Alternator (Leece Neville 15 volt-60, 65 amp)	3843	64
Auxiliary air spring installation	10675	189
Back window – body type 63	4839	153
Back window – body type 65	4476	101
Battery Carrier and Related Parts	4459	90
Booster Details (Bendix)	4590	137
Brake & Clutch Pedals	4472	100
Brake booster installation (Bendix)	4533	129
Brake cylinder details - front & rear	2990	30
Brake details - drum rear	3703	50
Brake details -disc front	4604	141
Brake master cylinder details	3098	34
Brake System, Disc/Drum	4470	99
Bumper, Front	4464	95
Bumper, Rear	4465	96
Camshaft, gear and bearings, 6 Cylinder 200, 250 C.I.D.	2964	27
Camshaft, gear and bearings, 8 Cylinder 289 C.I.D.	3733	55

Index, Alphabetical Order
1965 Mustang Part and Body Illustrations

Description	Diagram	Page
Carburetor – Ford 2V, 8 Cylinder 289 C.I.D.	4526	127
Carburetor – Ford 4V, 8 Cylinder 289 C.I.D.	4527	128
Carburetor – Ford Type, 6 Cylinder 200 C.I.D.	4728	145
Carburetor – Holley Type, 6 Cylinder 200 C.I.D.	7460	178
Child safety seat	11536	190
Console – with A/C	4602	140
Console – without A/C	4493	113
Control Valve Details - 6 cyl.	7454	177
Control Valve Details - 8 cyl.	7453	176
Convertible top, wiring	4548	132
Cooling Systems, 6 & 8 Cyl. Engines	3147	43
Courtesy lamp – Door mounted	4926	162
Courtesy lamp – instrument panel mounted	4734	146
Courtesy lamp – quarter panel mounted	4735	147
Crankshaft and flywheel, 6 Cylinder 170 C.I.D.	2965	28
Crankshaft and flywheel, 6 Cylinder 200, 250 C.I.D.	4899	159
Crankshaft and flywheel, 8 Cylinder 289 C.I.D.	3734	56
Cylinder block and cylinder head, 8 Cylinder 289 C	3767	62
Cylinder block, 6 Cylinder 200, 250 C.I.D.	3088	31
Cylinder Details	4180	74
Cylinder head, valves, and related parts, 8 Cyl.	3727	53
Distributor (6 cylinder 200 engines)	2961	24
Distributor (6 cylinder 240 engines)	3475	48
Distributor (8 cylinder - Pivot Plate type-exc. With stamped weights)	2926	23
Distributor (8 cylinder – with stamped weights)	4924	161
Drive Shaft	3144	42
Emergency Warning Flasher	4921	160
Emission Reduction System, rocker arm cover type-open system	4592	138
Engine assembly, 6 Cylinder 200, 250 C.I.D.	8398	181
Engine assembly, 8 Cylinder 260 C.I.D.	8393	179
Engine assembly, 8 Cylinder 289 C.I.D.	8396	180
Engine Supports	4500	119
Exhaust System, In-line, Before 10/15/64	EA-45	195

Index, Alphabetical Order
1965 Mustang Part and Body Illustrations

Description	Diagram	Page
Exhaust System, Regular Fuel, GT, Shelby, dual Exhaust from 10/15/64	EA-27	193
Exhaust System, Regular Fuel, Single Exhaust	EA-21	191
Exhaust System, Single Exhaust	EA-22	192
Exhaust System, Transverse, Before 10/15/64	EA-28	194
Exterior Moulding, All,	4490	110
Fender and apron sheet metal	9205	187
Fog, lights	4889	158
Folding top parts – less trim – body type 76	4479	104
Front and rear wheel, hub, & bearing	3118	35
Front seat – full width	4885	157
Front seats – bucket - body types 63A, 65, and 76A	4455	86
Front Suspension	3120	36
Fuel pump, 6 Cylinder 200 C.I.D.	4367	81
Fuel pump, 8 Cylinder 260/289 C.I.D.	3715	51
Fuel System	4499	118
Generator and Related Parts (Ford 15 volt – 25, 30 amp)	3192	45
Handles and latch parts (front door)	4495	115
Headlamp	4460	91
Heater	4540	130
Hinges – front door lower	6981	175
Hinges - front door upper	6980	174
Hood	4462	93
Horn Ring, Steering Wheel and related parts – non-woodgrain wheel	4514	123
Instrument Cluster and Related Parts – w/Gauges	8973	184
Instrument Cluster and Related Parts – w/Warning Lights	8985	186
Instrument panel and pad – w/gauges	8972	183
Instrument panel and pad – w/indicator lights	8984	185
Intake manifold & related parts, 8 Cylinder 289 CID Engine	3742	59
Intake manifold type-open system, 8 Cylinder 289 C	4146	72
Interior trim parts (Convertible)	4457	88
Interior trim parts (Two door hardtop fastback roof)	4767	149
Interior trim parts (Two door hardtop formal roof)	4456	87
Interior trim parts, folding top compartment trim	3446	47

Index, Alphabetical Order
1965 Mustang Part and Body Illustrations

Description	Diagram	Page
Jack and spare wheel parts	4596	139
Latch parts – body type 63 (luggage compartment)	4844	154
Latch parts – body type 65, 70 (luggage compartment)	4477	102
Luggage and ski carrier – non adjustable – roof mounted	4863	156
Mirror – remote control	4543	131
Oil filters - cartridge type	1246	18
Oil filters - spin-on type	2384	21
Oil pump, 6 Cylinder 200, 250 C.I.D.	2963	26
Oil pump, 8 Cylinder 260, 289,302,351,400,429,460 C.I.D.	3736	57
Parking Lamp	4461	92
Piston and connecting rod, 6 Cyl and 8 Cyl 260, 289,302,351,400,429,460 C.I.D.	3732	54
Piston and connecting rod, 6 Cylinder 200, 250 C.I.D.	3090	33
Power Steering System - 6 cyl.	4606	143
Power Steering System - 8 cyl.	4605	142
Pump Details - Eaton Type	9579	188
Pump Details - Ford Type	4574	135
Radiator Grille and Related Parts	4458	89
Rear Axle Equa Lock (integral carrier) and Non-Locking (integral carrier)	5796	171
Rear Axle Locking - Equa Lock (separate carrier)	2819	22
Rear Axle Non-Locking (separate carrier)	2130	20
Rear lamp, back up & license plate	4463	94
Rear seat – folding – body type 63	4764	148
Rocker arm cover type-closed system, 6 Cylinder 200, 250	8408	182
Rocker arm cover type-open system, 6 Cylinder 200	4389	84
Roof side mouldings and weatherstrips – body type 63	4838	152
Roof side mouldings and weatherstrips – body type 65	4478	103
Sheet Metal, Convertible - Under body	4487	107
Sheet Metal, Convertible - Upper body	4489	109
Sheet Metal, Two door hardtop fastback roof - Upper	4640	144
Sheet Metal, Two door hardtop fastback/formal roof	4486	106
Sheet Metal, Two door hardtop formal roof - Upper	4488	108

Index, Alphabetical Order
1965 Mustang Part and Body Illustrations

Description	Diagram	Page
Shock absorber - front	3129	40
Shock absorber - rear	3137	41
Springs	3125	39
Starter and Drive Assy. – Positive Engagement	3191	44
Starter Drive (Ford 12 volt – positive engagement)	5526	168
Steering column - floor shift	6366	173
Steering Gear Details	3122	38
Steering Linkage - 6 & 8 cyl. with Eaton pump	4139	71
Steering Linkage - 6 cyl.	3121	37
Steering Linkage - 8 cyl.	4483	105
Steering Wheel, 3 Spoke – woodgrain wheel	4955	164
Thermostatic choke control - except Hi-Performance	4940	163
Transmission Automatic, bushings	4862	155
Transmission Automatic, Shift control selector mechanism, Automatic	4501	120
Transmission Automatic, Vacuum throttle valve, lines and fittings - typical	3627	49
Transmission C4 Type, Case, converter assy., extension, pump - typical	4326	76
Transmission C4 Type, Clutches, gears, shafts, rear support - typical	4327	77
Transmission C4 Type, Main control valve body assy. (Basic 7A100) - typical	4507	121
Transmission C4 Type, Parking pawl, throttle and manual control linkage - typical	4330	80
Transmission C4 Type, Servo and band, front - typical	4328	78
Transmission C4 Type, Servo and band, rear - typical	4329	79
Transmission Oil cooling system, automatic - typical	4148	73
Transmission, Manual, 3 Speed manual trans 2.77 type	2966	29
Transmission, Manual, 3 Speed manual trans 3.03 type	4012	68
Transmission, Manual, 3 speed trans, Gear shift mechanism - console or floor mtd	4516	124
Transmission, Manual, Dagenham 4 speed forks, lever	3904	67
Transmission, Manual, Dagenham 4 speed less forks,	3903	66
Transmission, Manual, Ford 4 speed	4424	85
Transmission, Manual, Ford 4 speed, Gear shift mechanism - console or floor mtd	5810	172
Transmission, Manual, Warner 4 speed forks, levers	3745	61
Transmission, Manual, Warner 4 speed less forks, l	3744	60
Valves, push rods and rocker arm cover, 6 Cyl and 8 Cyl 260,	3726	52

Index, Alphabetical Order
1965 Mustang Part and Body Illustrations

Description	Diagram	Page
Valves, push rods and rocker arm cover, 6 Cylinder	3089	32
Ventilating ducts	4020	69
Voltage Regulator – typical (Generator)	1535	19
Voltage Regulator (Ford 15 volt, negative ground)	5525	167
Washer, windshield	4525	126
Water Pumps, 6 cyl. - 200, 250 engines	2962	25
Water Pumps, 8 cyl. - 260, 289 engines (without cover)	3772	63
Water Pumps, 8 cyl. - 289, 302, 351W engine (with cover)	5143	165
Window parts (front door) 4494	4494	114
Window parts (quarter) – body types 65, 76	4496	116
Windshield – body type 76	4492	112
Windshield – body types 63, 65	4491	111
Windshield Wiper	4524	125
Wiper motor (2 speed Ford electric)	4200	75
Wiper motor (single speed Ford electric)	5376	166
Wiring System	4498	117

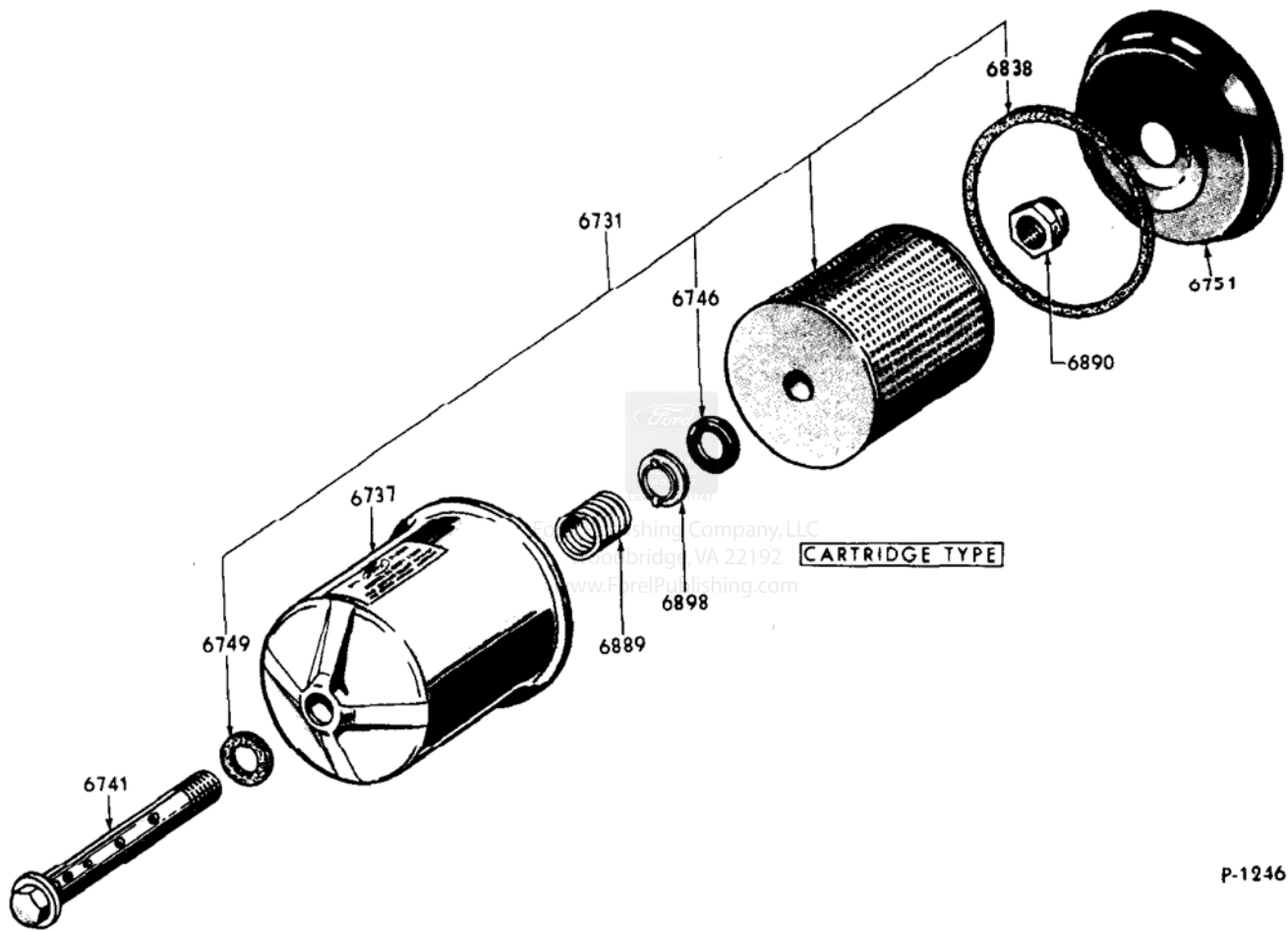

P-1246

**ENGINE FILTER AND RELATED PARTS - CARTRIDGE TYPE - TYPICAL
 1965 / 72 6 CYLINDER 170, 200, 240, 250 AND 8 CYLINDER 260, 289, 302 AND 351**

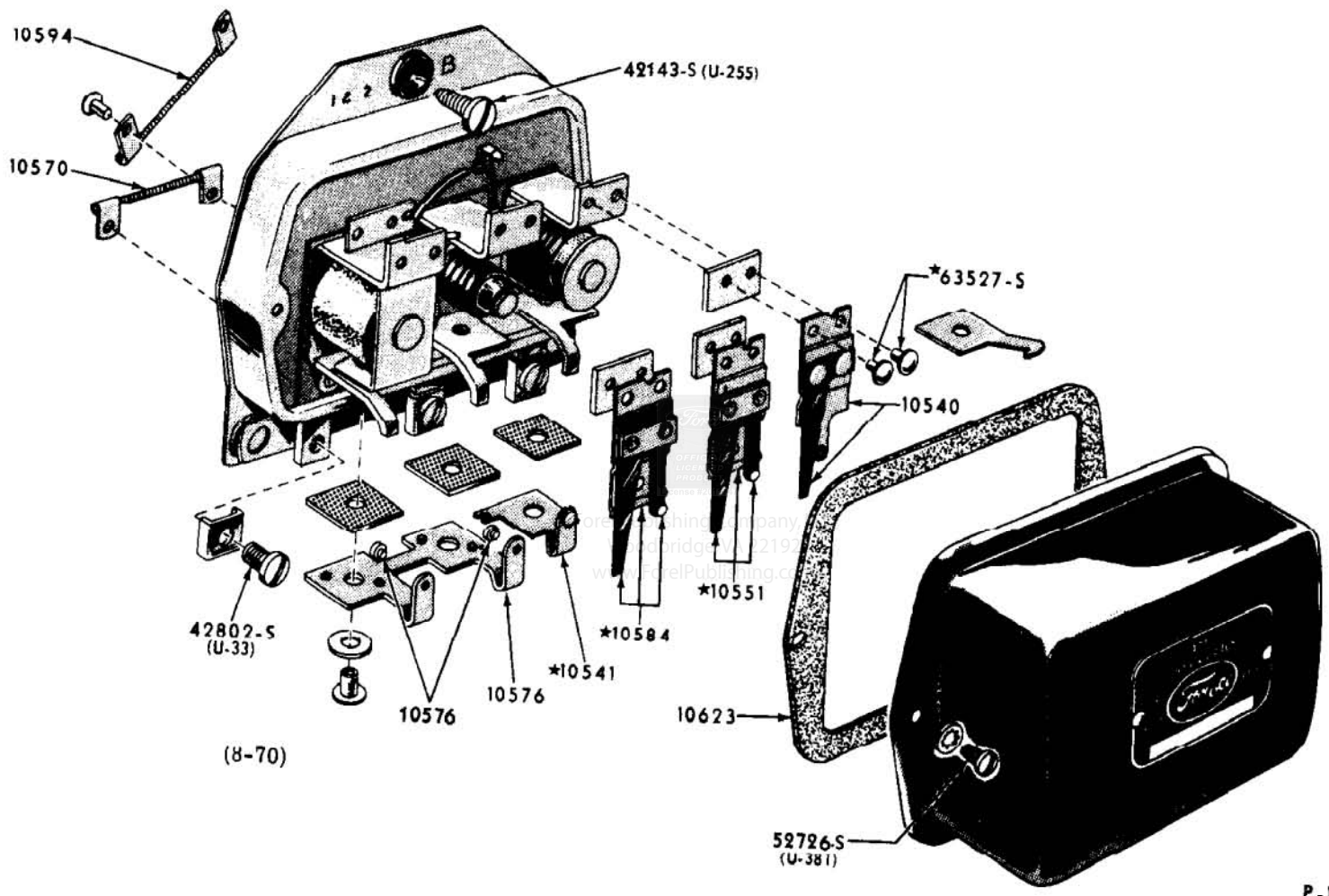

P-1535

VOLTAGE REGULATOR - TYPICAL (GENERATOR)
1965

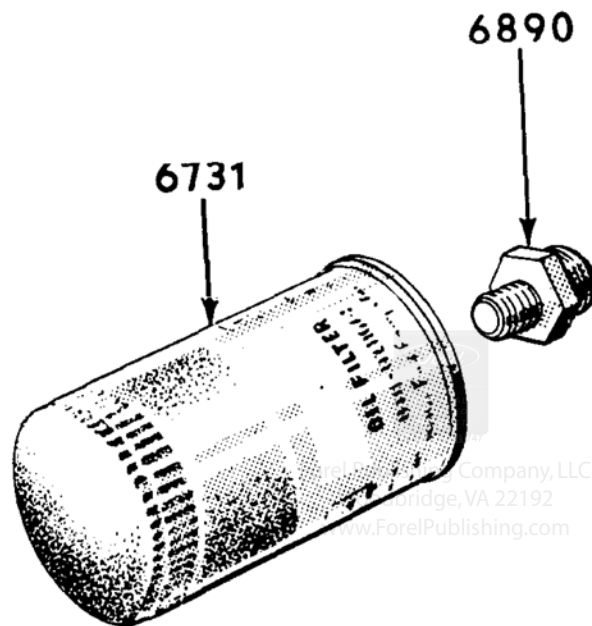

P-2384

ENGINE FILER AND RELATED PARTS - SPIN-ON TYPE - TYPICAL

1965 / 72 6 CYLINDER 170, 200, 240, 250 AND 8 CYLINDER 260, 289, 302, 351, 352, 390, 400, 427, 428, 429 AND 460

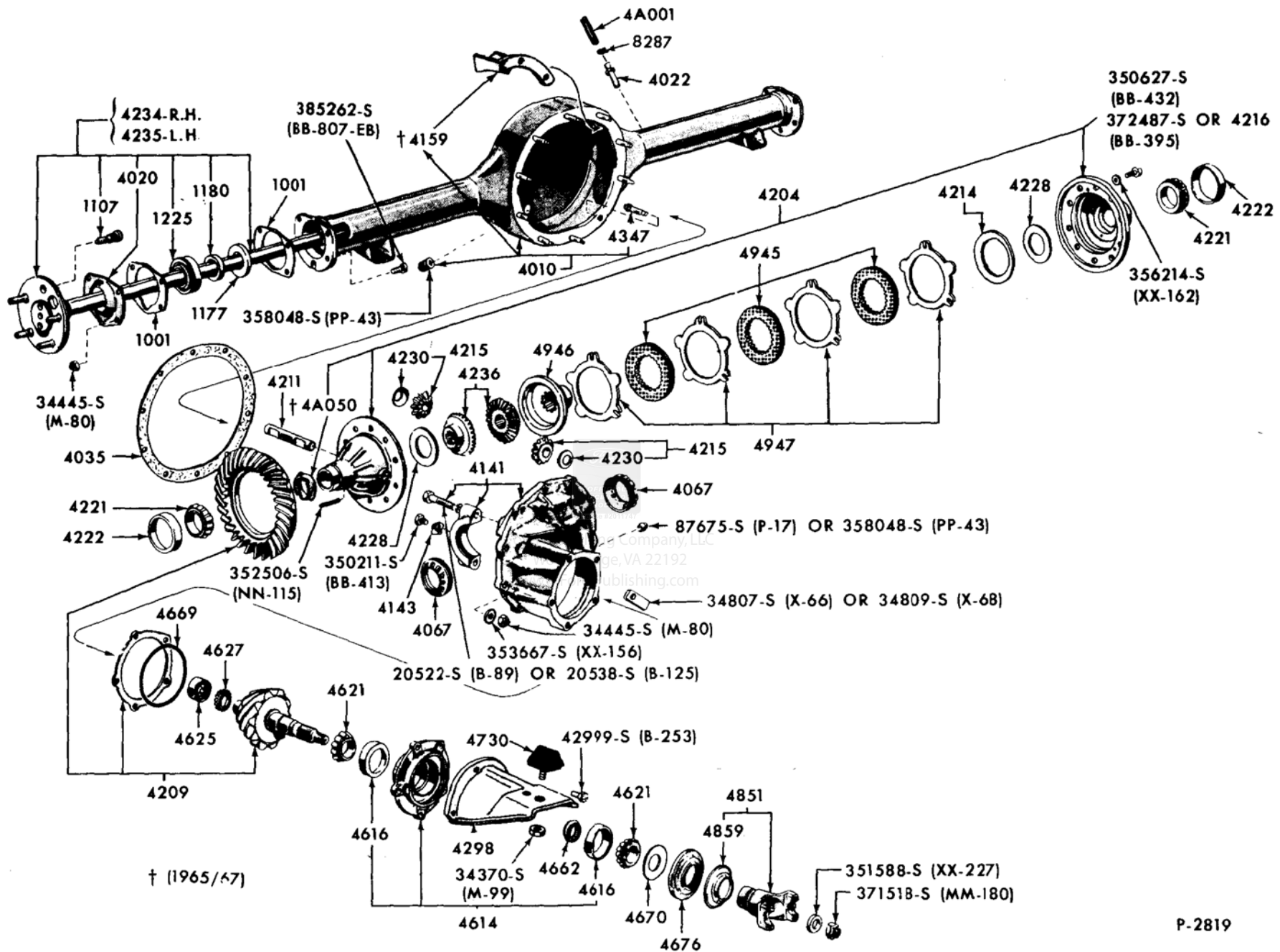

REAR AXLE - LOCKING (EQUA LOCK) WITH SEPARATE CARRIER - TYPICAL
 7 3/4", 8", 8 3/4", 9" RING GEAR

1966 /69 BRONCO, 1965 / 70 FALCON, 1965 / 68 FAIRLANE/TORINO, MUSTANG, 1965 / 69 FORD, 1965 / 67 THUNDERBIRD

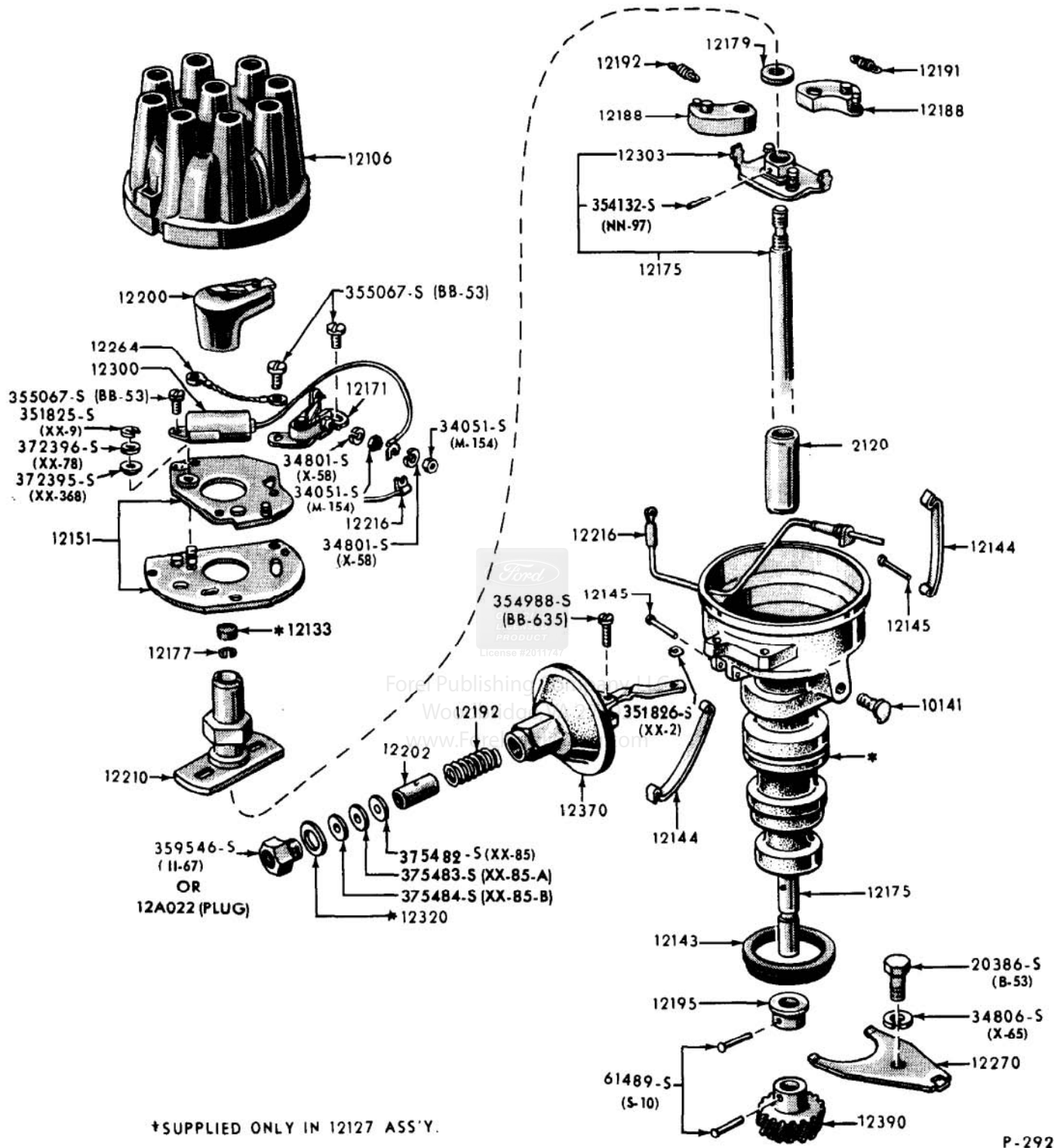

† SUPPLIED ONLY IN 12127 ASS'Y.

P-2926

**DISTRIBUTOR - (PIVOT PLATE EXCEPT WITH STAMPED WEIGHTS)
1965 / 67 8 CYLINDER - ALL**

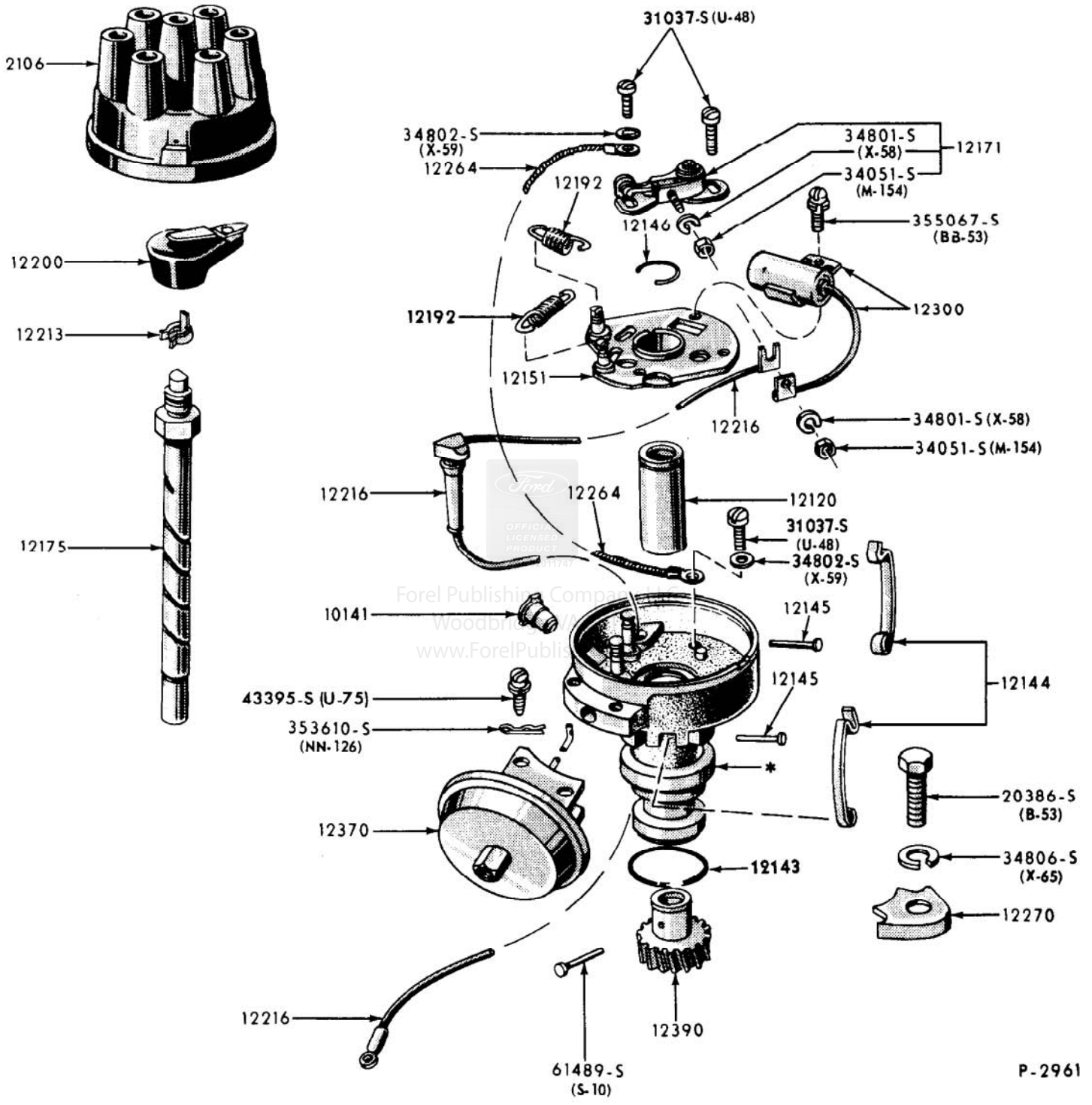

DISTRIBUTOR
1965 / 69 6 CYLINDER 170, 200 ENGINES

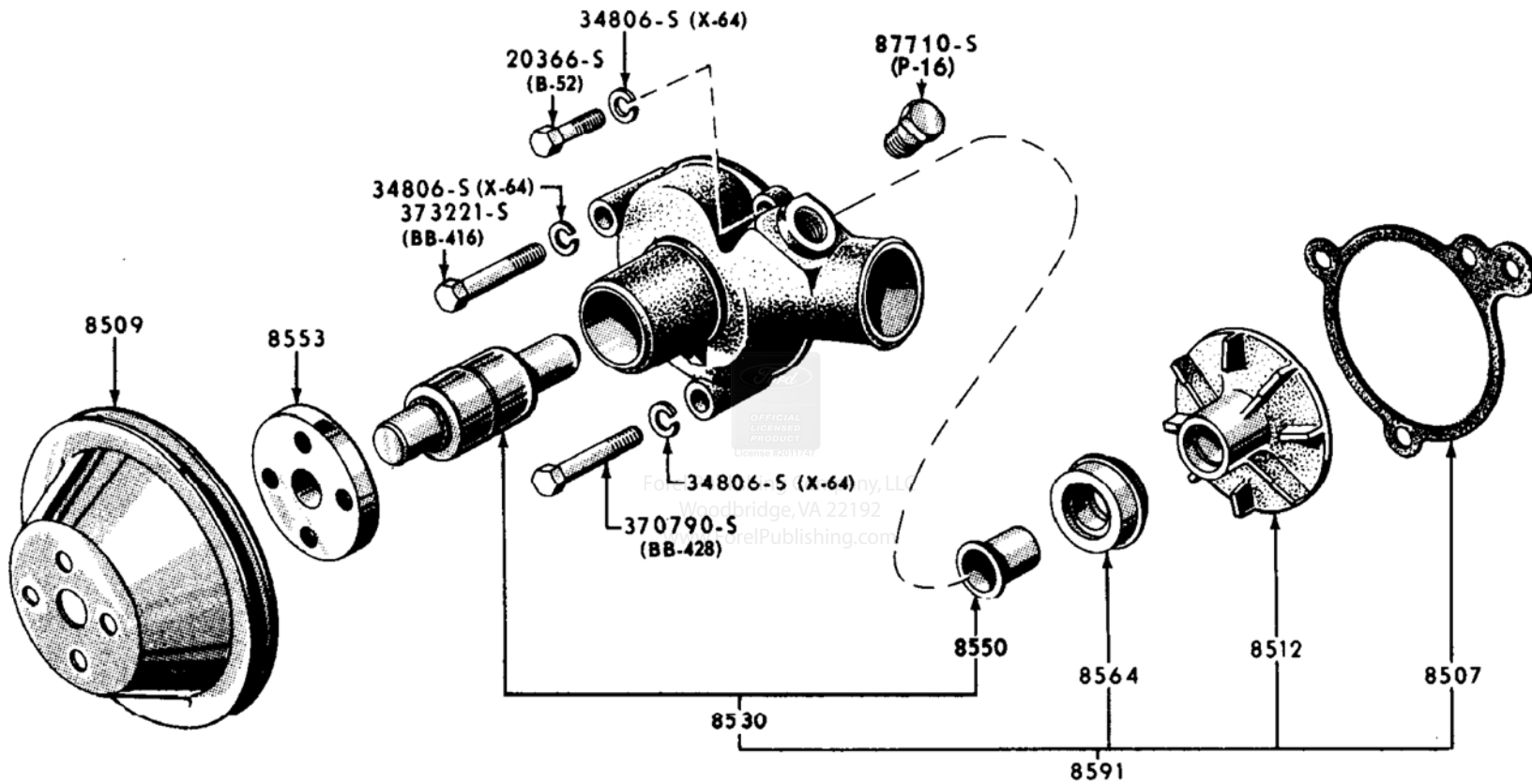

P-2962

WATER PUMP
 1965 / 72 6 CYLINDER 170, 200 AND 250

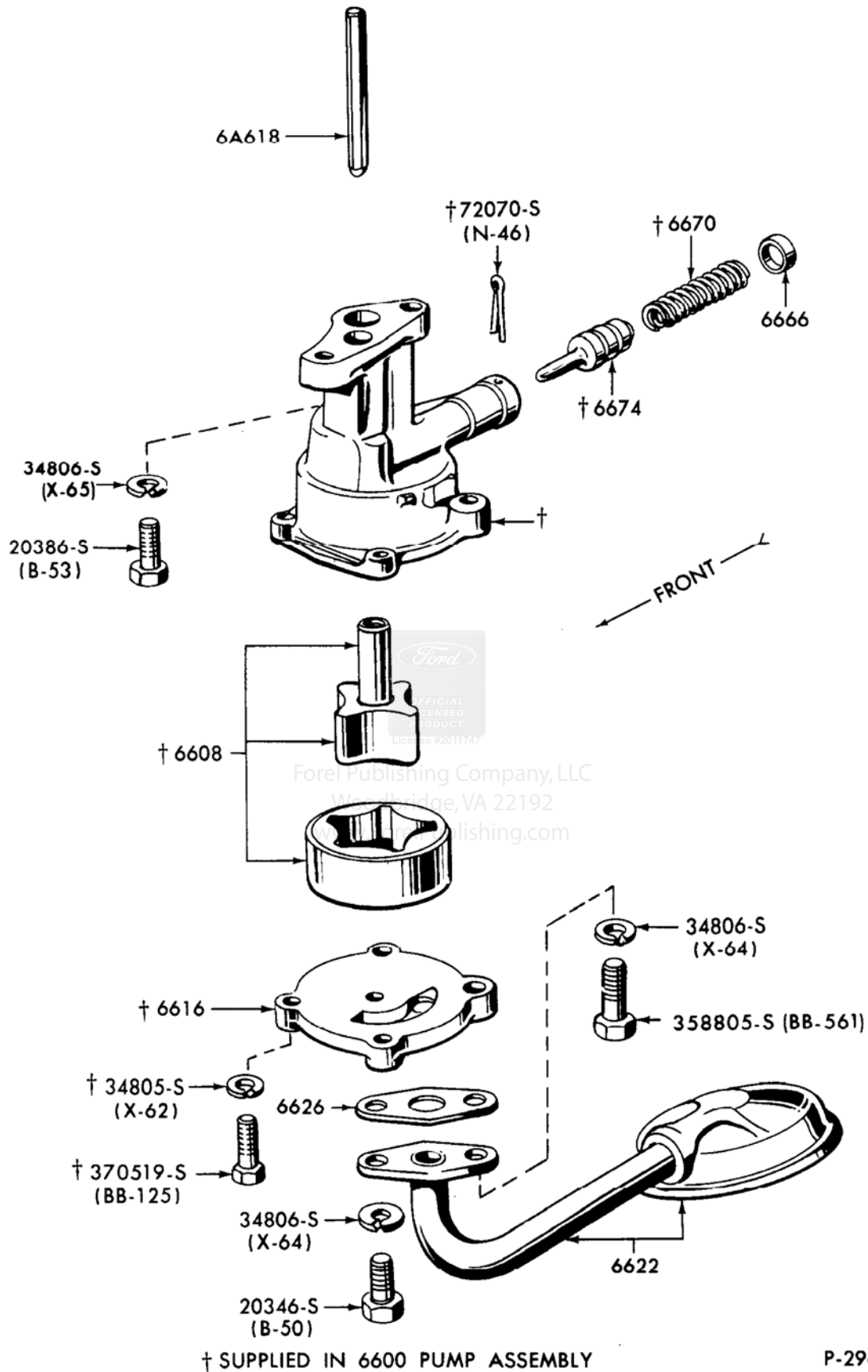

ENGINE OIL PUMP AND RELATED PARTS -- TYPICAL
1965/72 6 CYLINDER 170, 200 AND 250

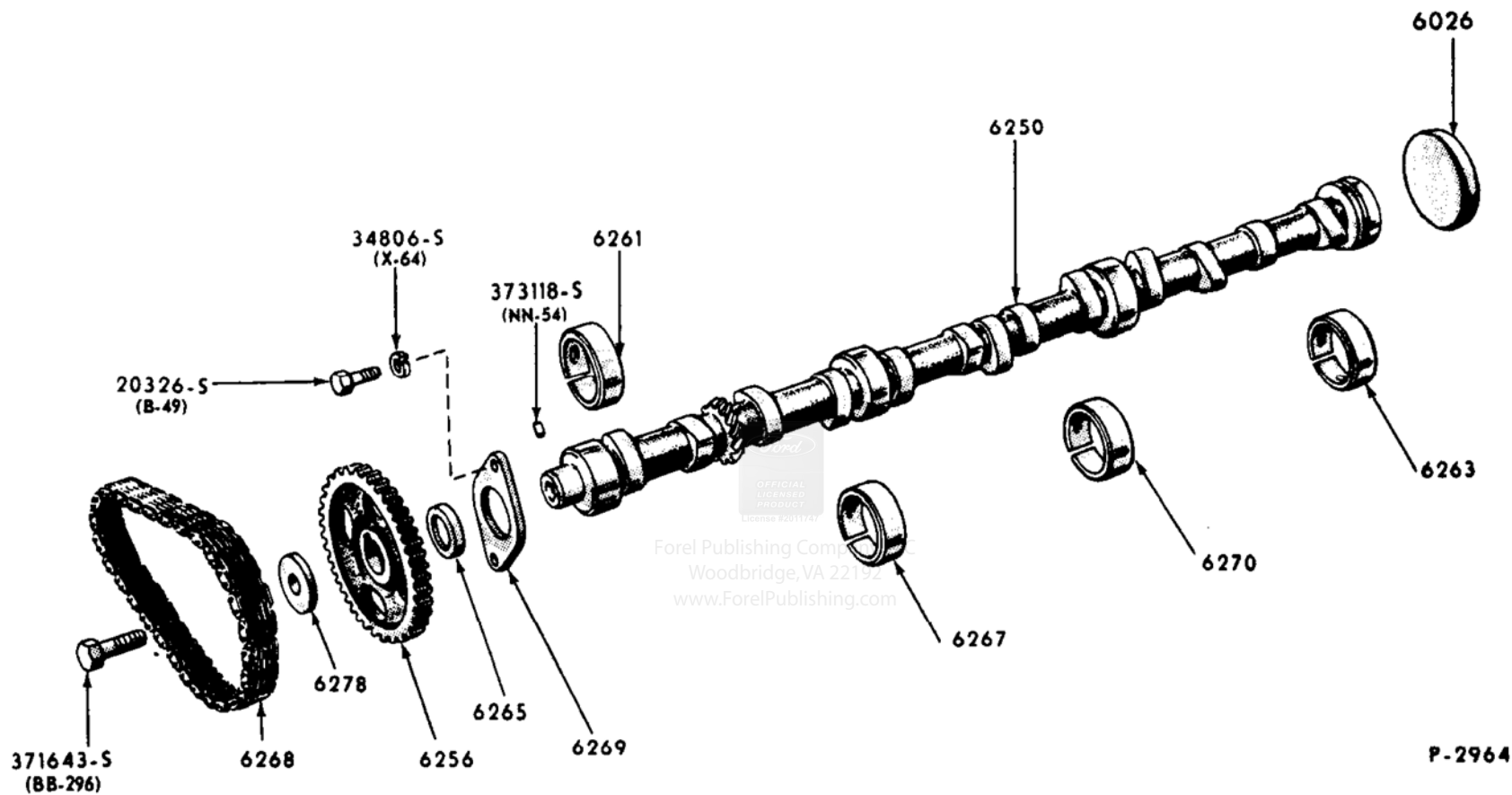

ENGINE CAMSHAFT, GEAR, BEARINGS AND RELATED PARTS -- TYPICAL
 1965 / 72 6 CYLINDER 170, 200 AND 250

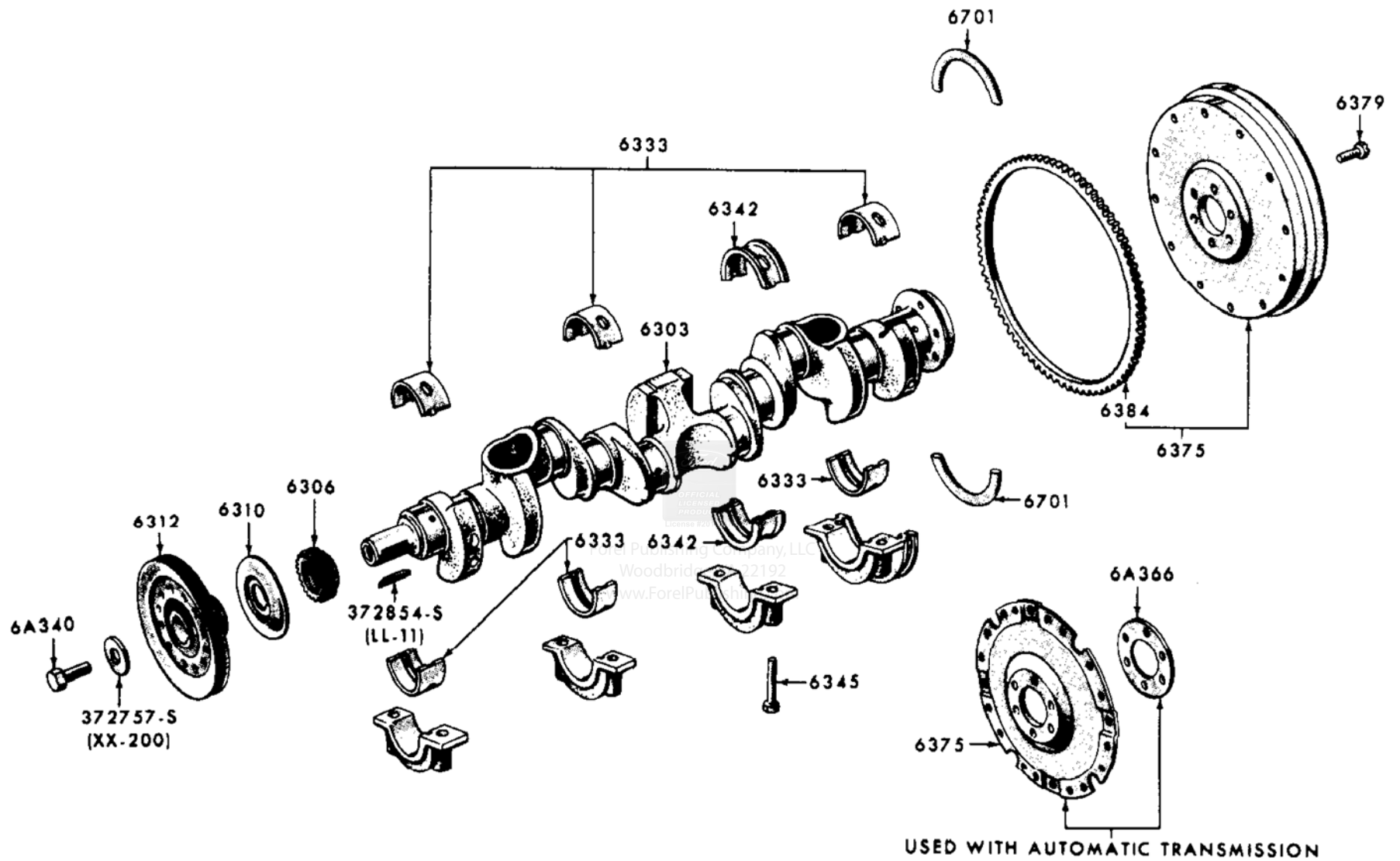

P-2965

ENGINE CRANKSHAFT, FLYWHEEL AND RELATED PARTS -- TYPICAL
1965 / 72 6 CYLINDER 170

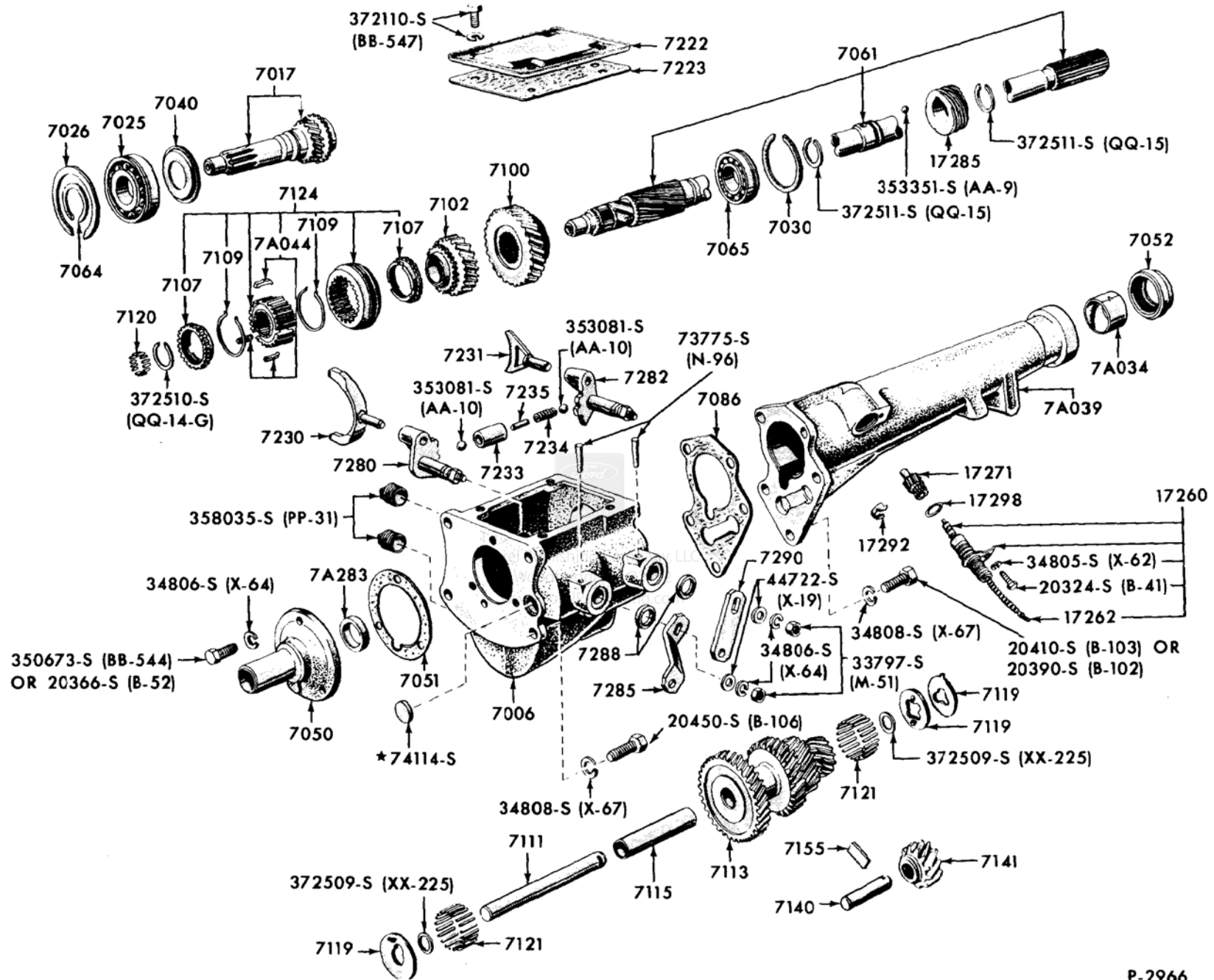

P-2966

3 SPEED MANUAL TRANSMISSION - 2.77 TYPE - TYPICAL
 1965 / 67 FAIRLANE, MUSTANG, FALCON

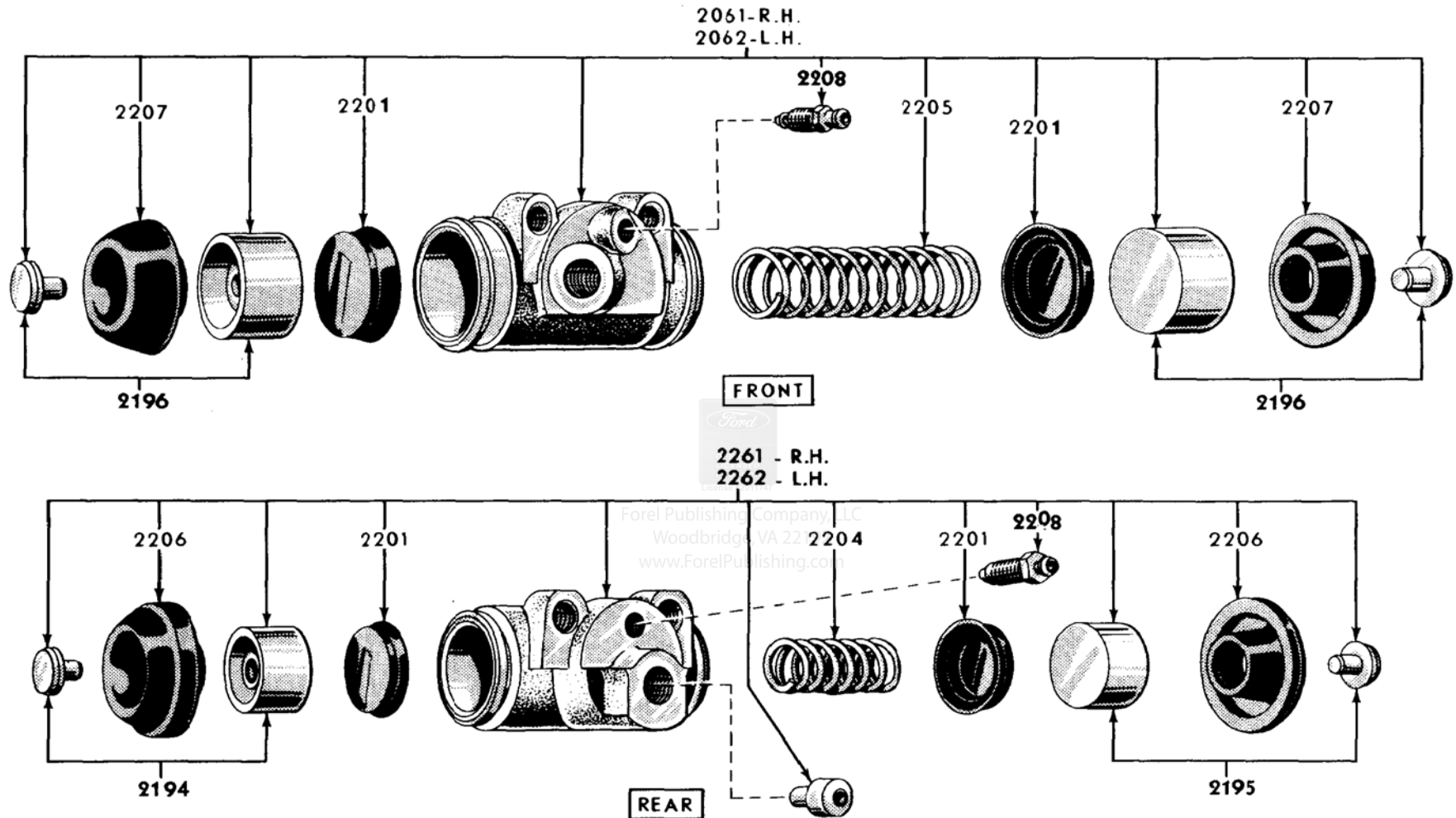

P-2990

**BRAKE CYLINDER
1965 FALCON AND MUSTANG**

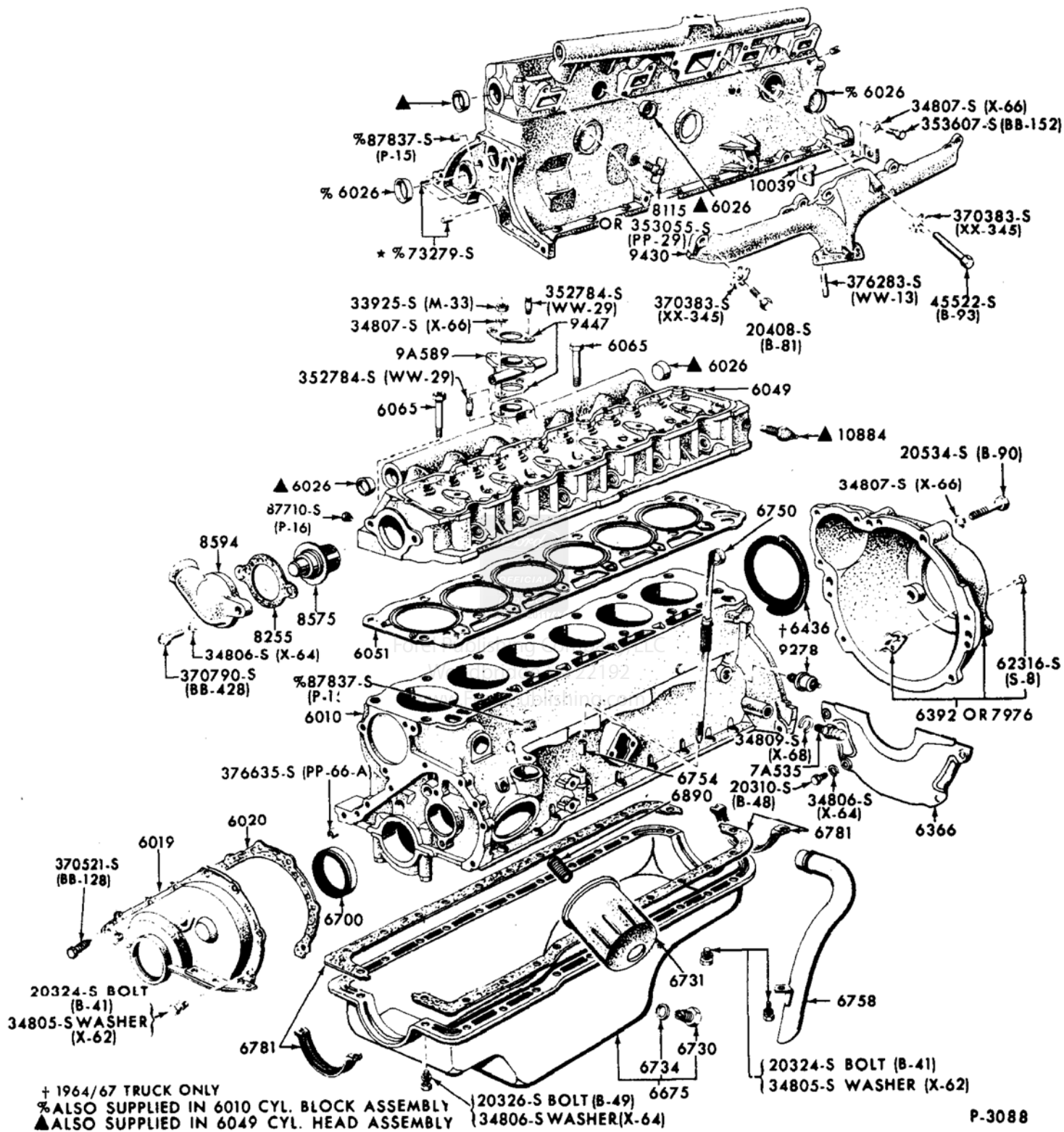

CYLINDER BLOCK AND RELATED PARTS
6 CYLINDER 170, 200 AND 250 ENGINES -- TYPICAL
1965 / 72

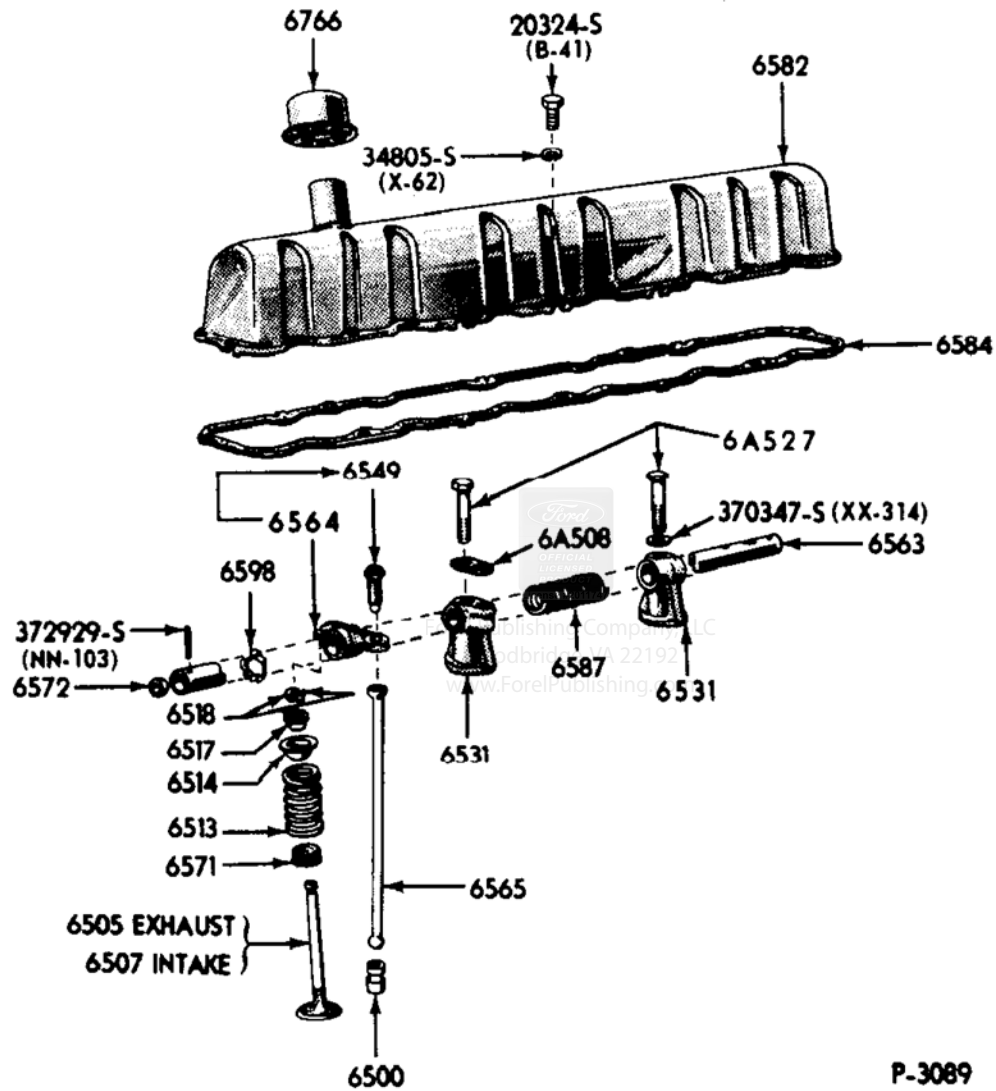

ENGINE VALVES, PUSH RODS, ROCKER ARM COVER AND RELATED PARTS -- TYPICAL
 1965/72 6 CYLINDER 170, 200 AND 250

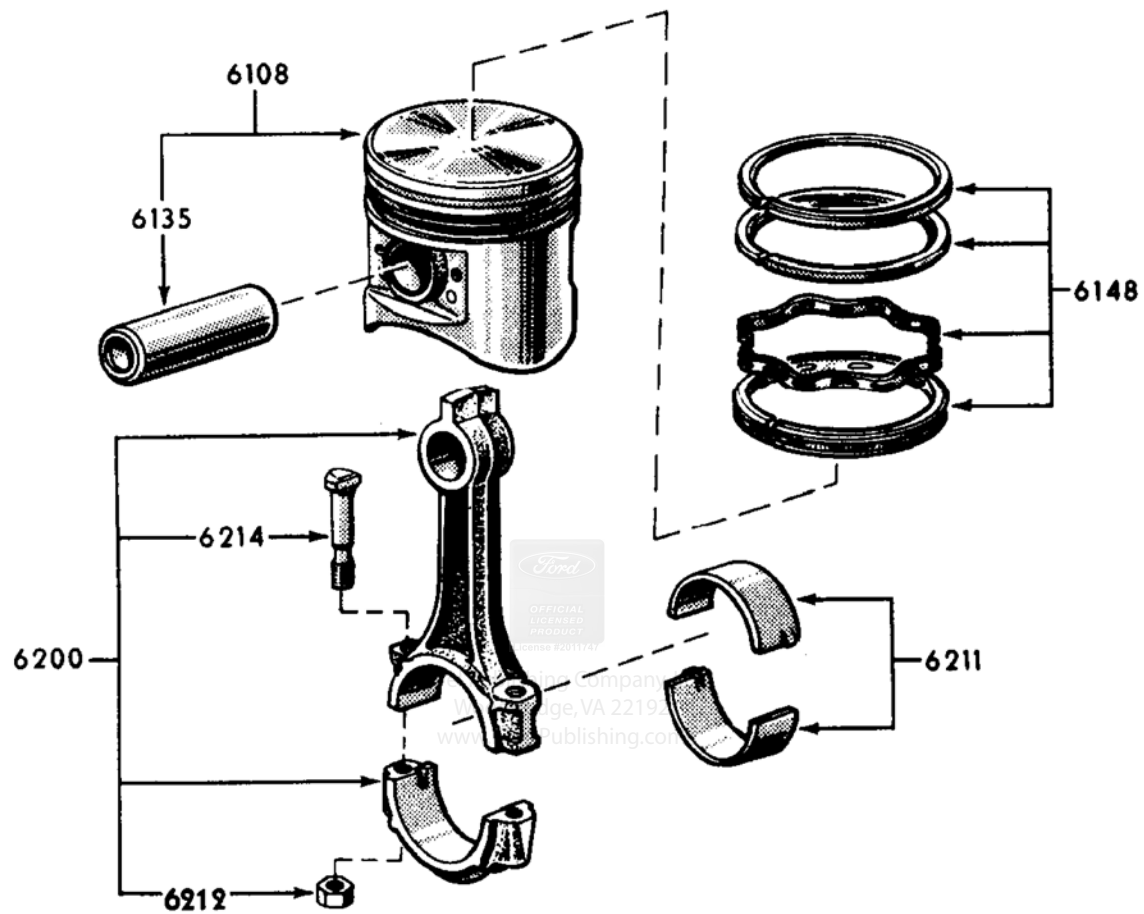

P-3090

ENGINE PISTON, CONNECTION ROD AND RELATED PARTS -- TYPICAL
1965 /72 6 CYLINDER 170, 200 AND 250

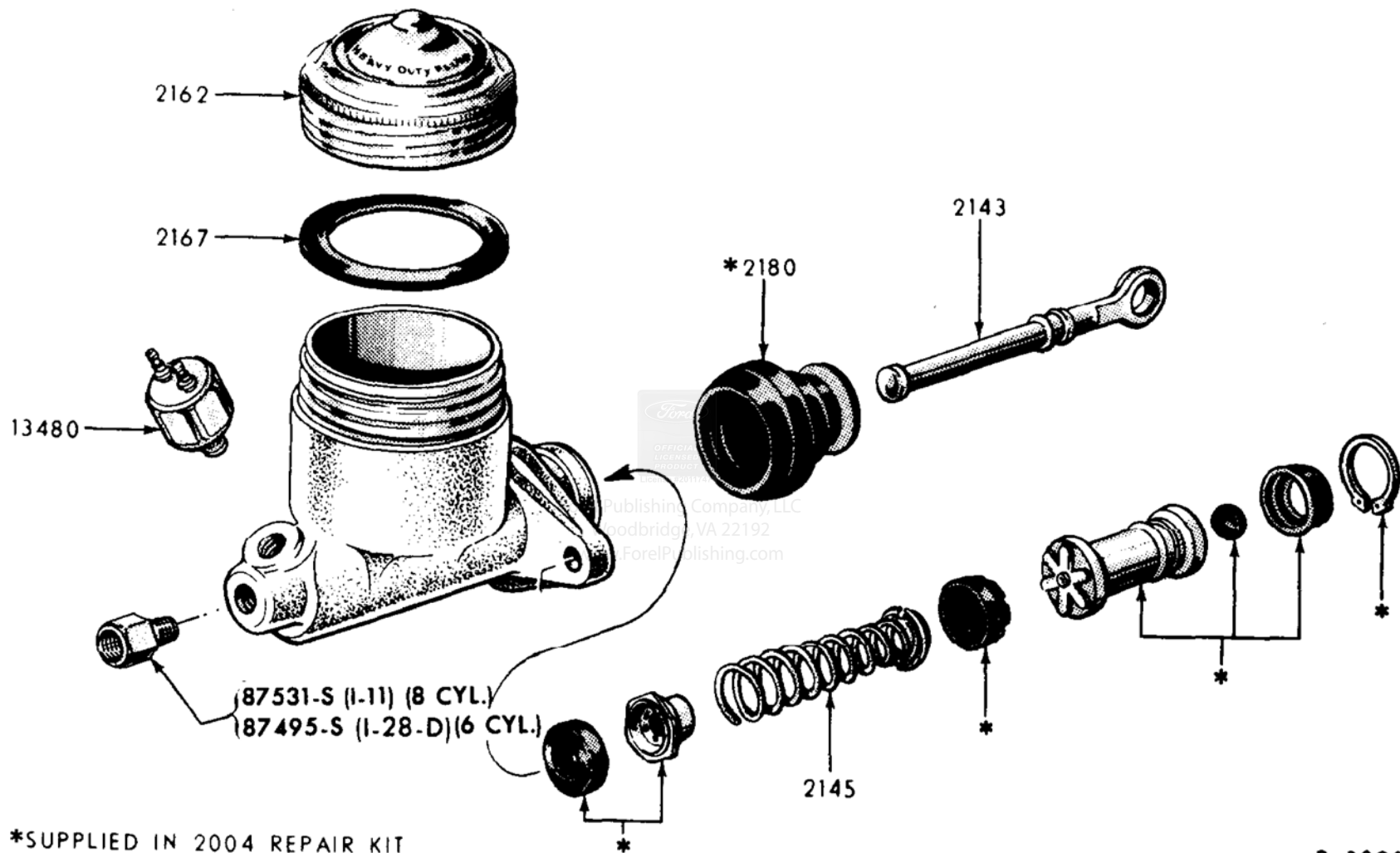

P-3098

BRAKE MASTER CYLINDER - TYPICAL
 1965/66 FORD, FAIRLANE, FALCON, MUSTANG, THUNDERBIRD and 1966 BRONCO

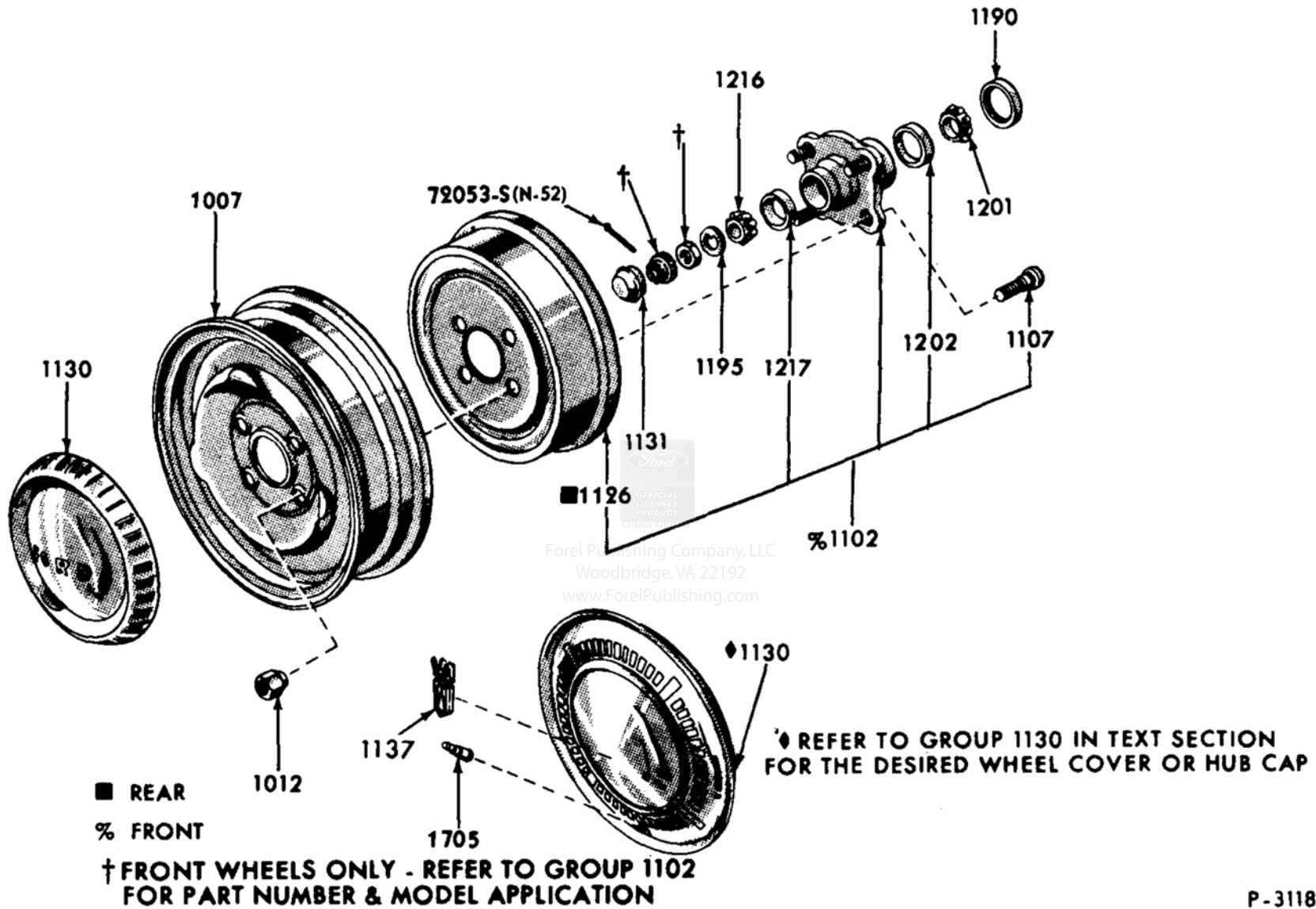

FRONT & REAR WHEEL, HUB, & BEARINGS - TYPICAL
 1965/72 FAIRLANE/TORINO, FALCON, MAVERICK, MUSTANG 1971 PINTO

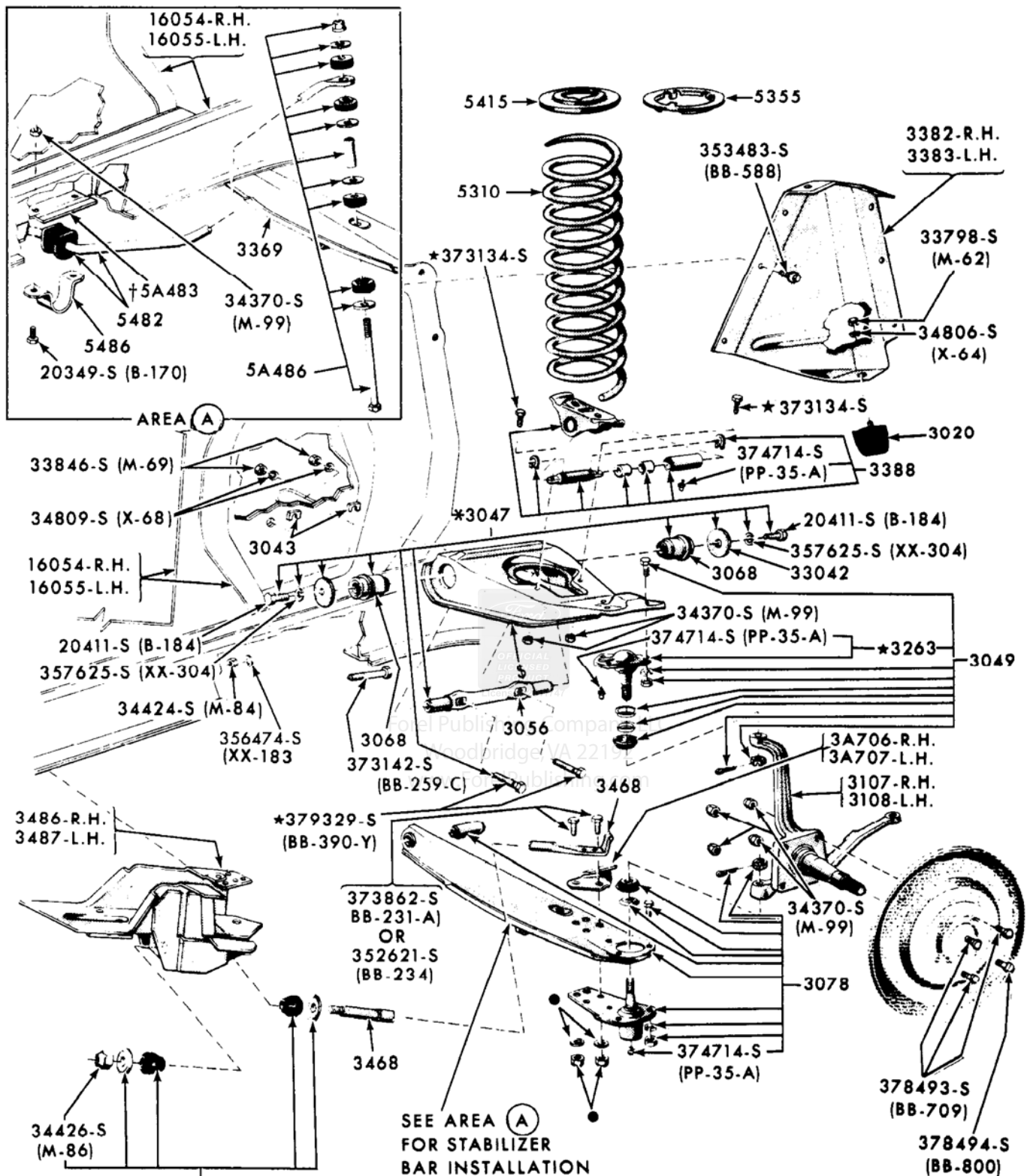

- † FALCON ONLY
- * ALSO SUPPLIED IN 3082 UPPER ARM, SHAFT AND JOINT ASSEMBLY
- SUPPLIED IN 3468 LOWER ARM STRUT REPAIR KIT
- SUPPLIED IN 3082 UPPER ARM ASSY
- & SUPPLIED ONLY IN 3082 UPPER ARM, SHAFT AND JOINT ASSEMBLY

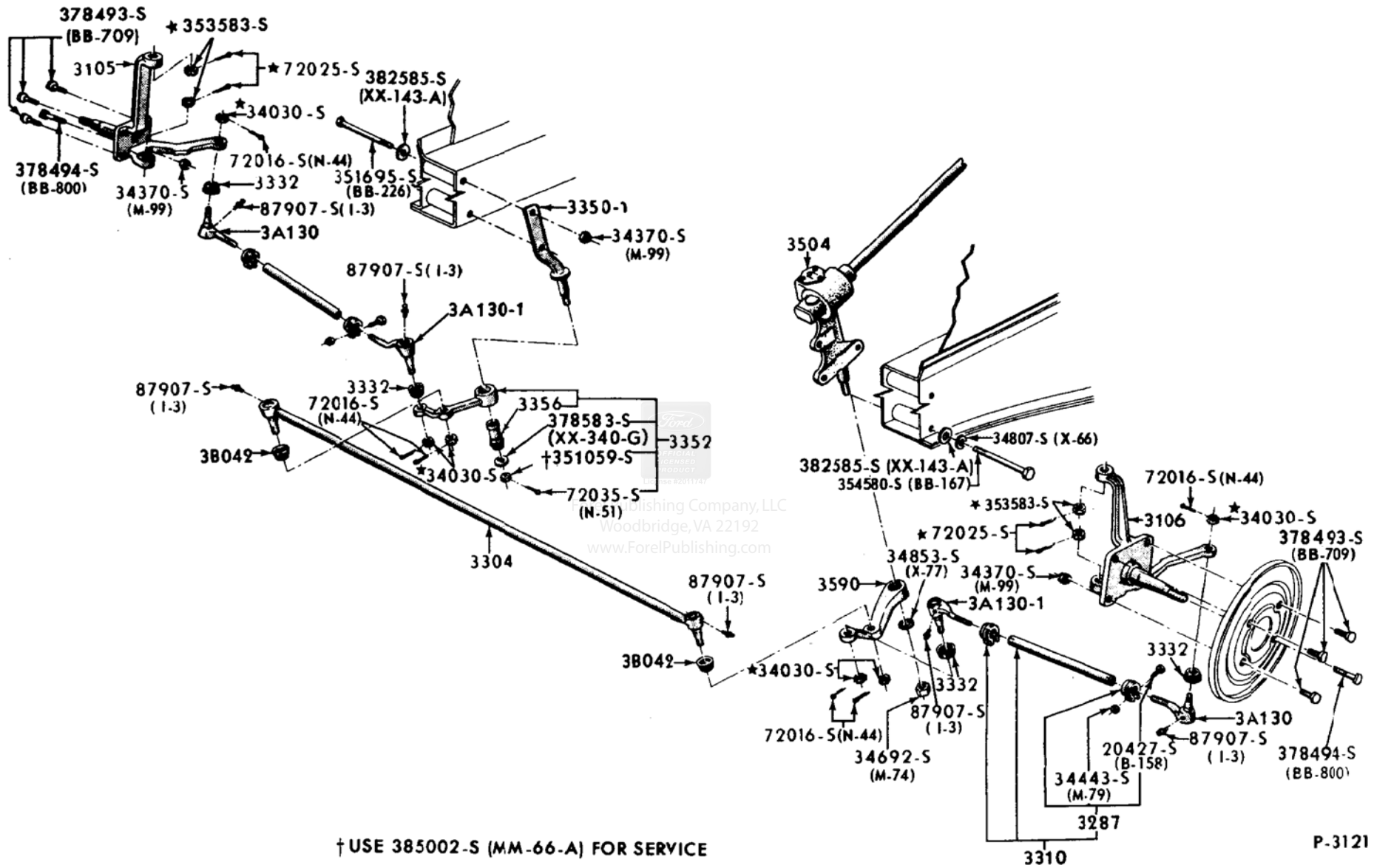

MANUAL STEERING LINKAGE - 6 CYLINDER
 1965 FALCON, 1965 / 66 MUSTANG

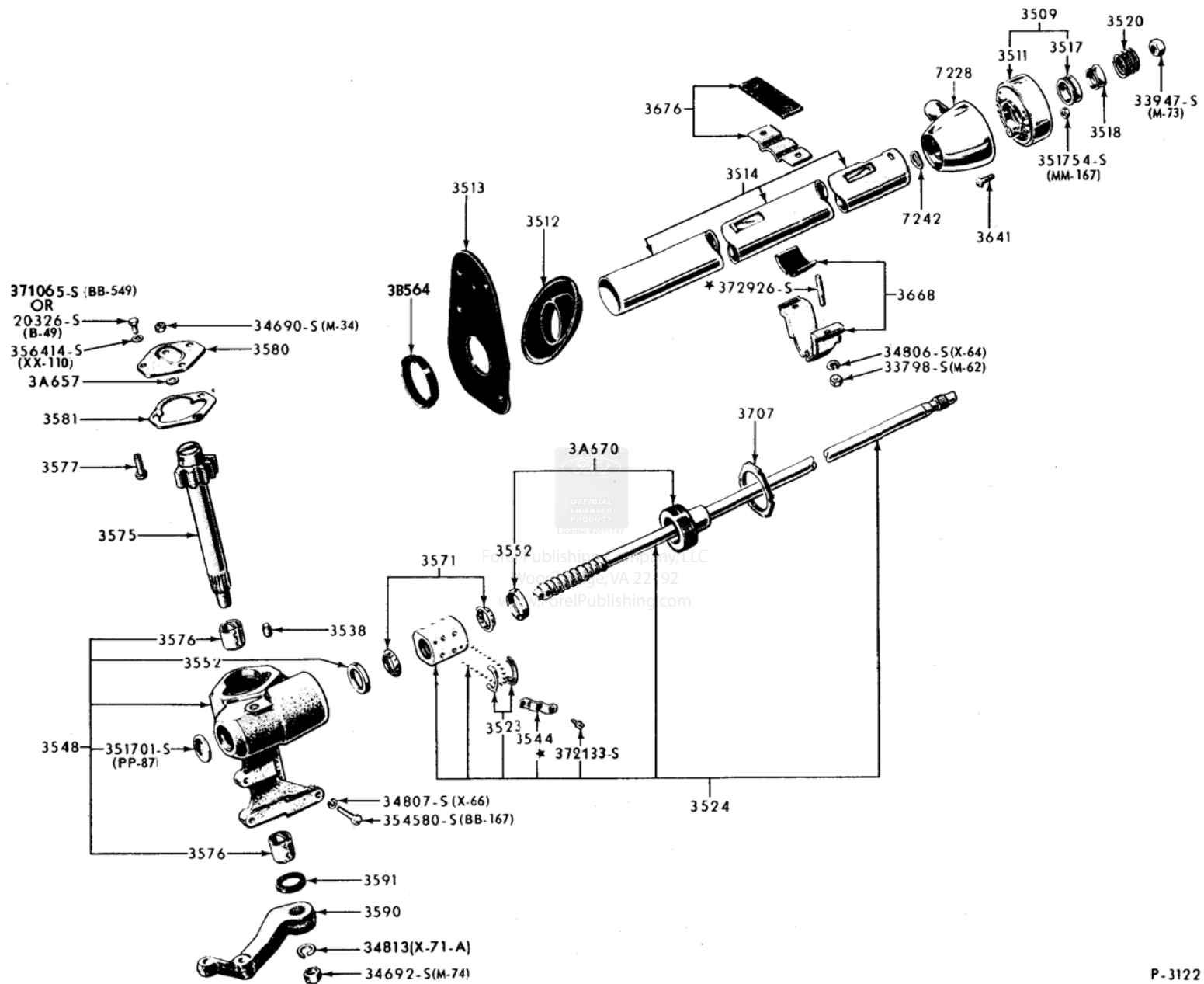

STEERING GEAR DETAILS
1965 FALCON & MUSTANG

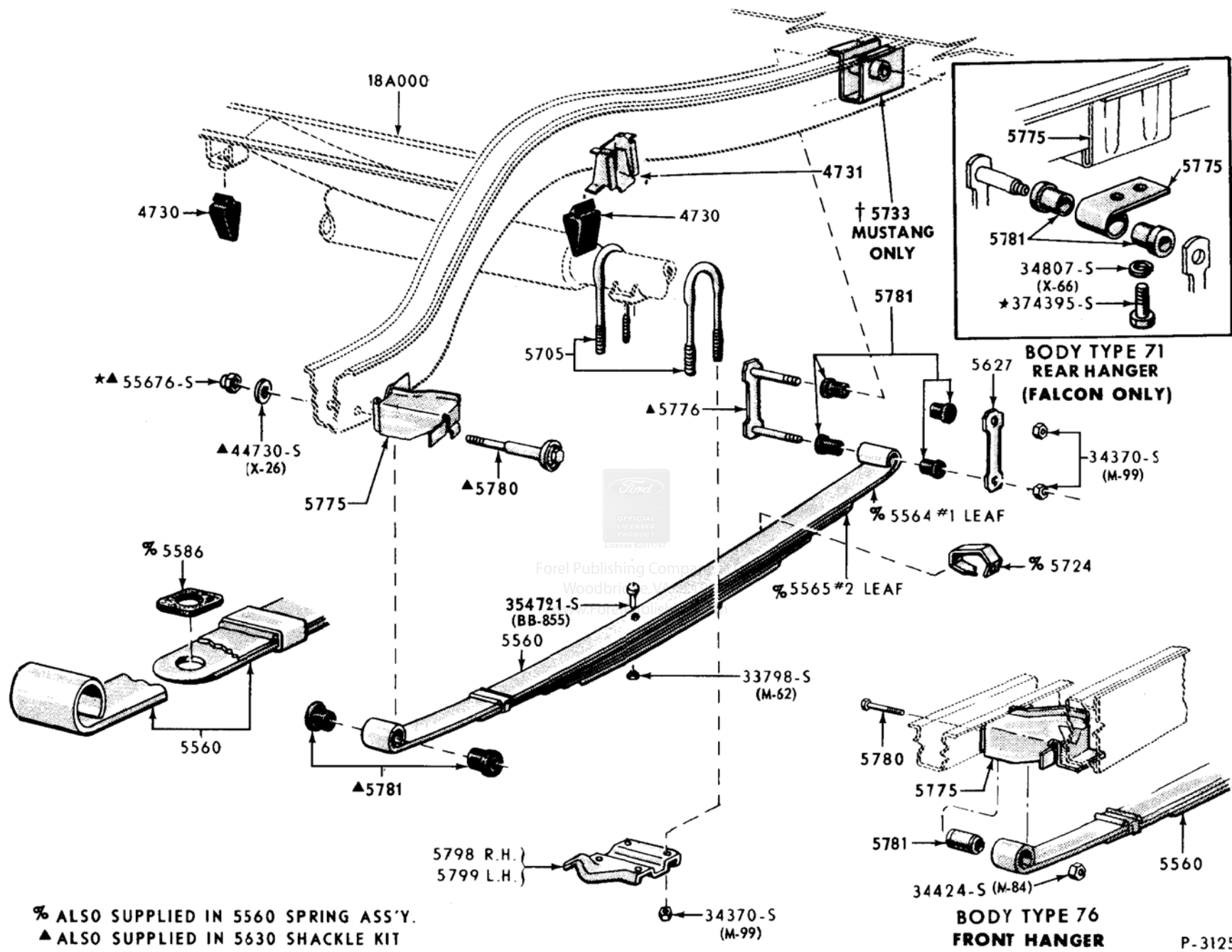

% ALSO SUPPLIED IN 5560 SPRING ASS'Y.

▲ ALSO SUPPLIED IN 5630 SHACKLE KIT

† SERVICED ONLY IN ASSY.-GROUP 10124-5. REFER TO BODY SECTION

REAR SUSPENSION
1965 / 70 MUSTANG 1965 FALCON

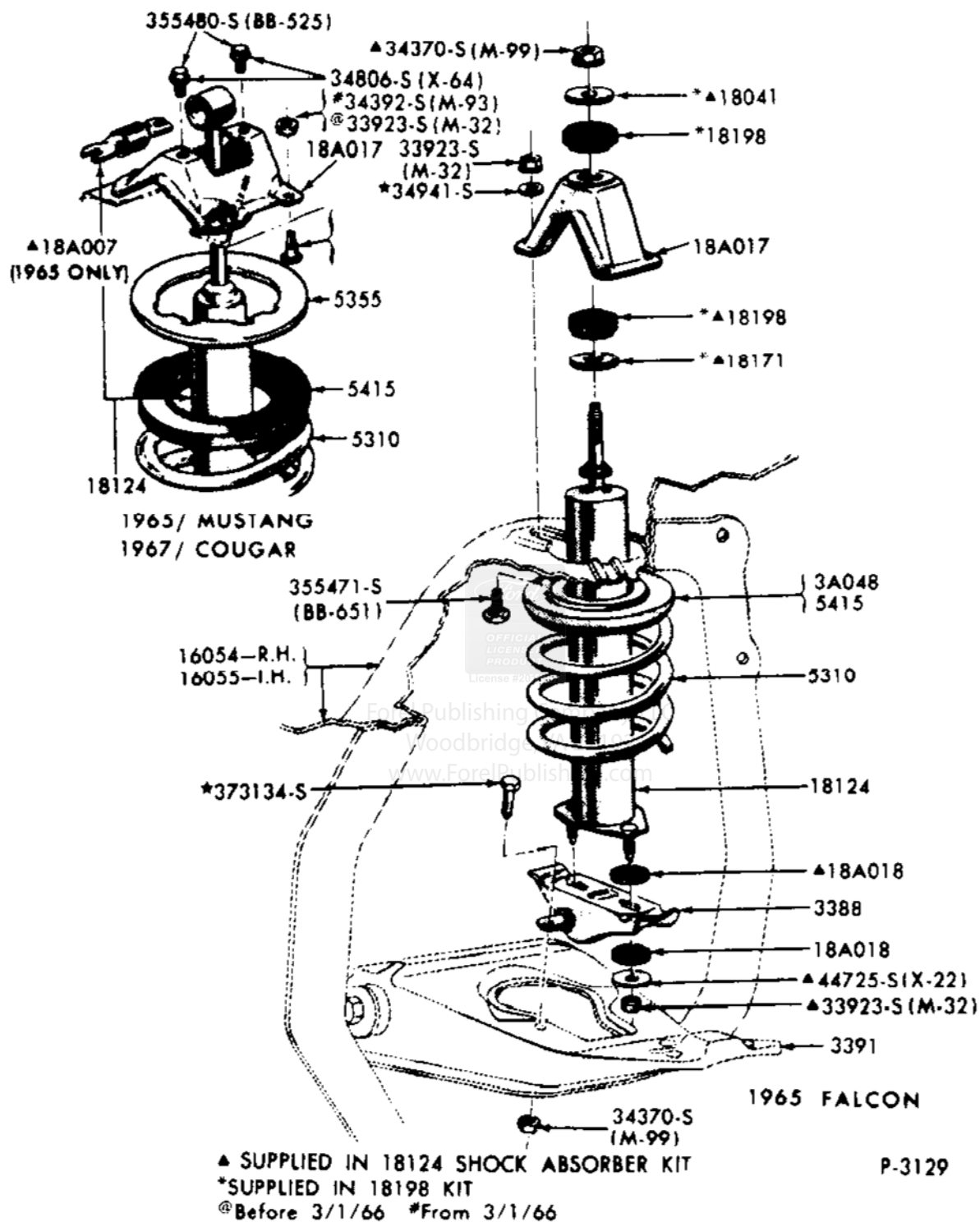

SHOCK ABSORBER - FRONT
1965 FALCON AND 1965 / 69 MUSTANG

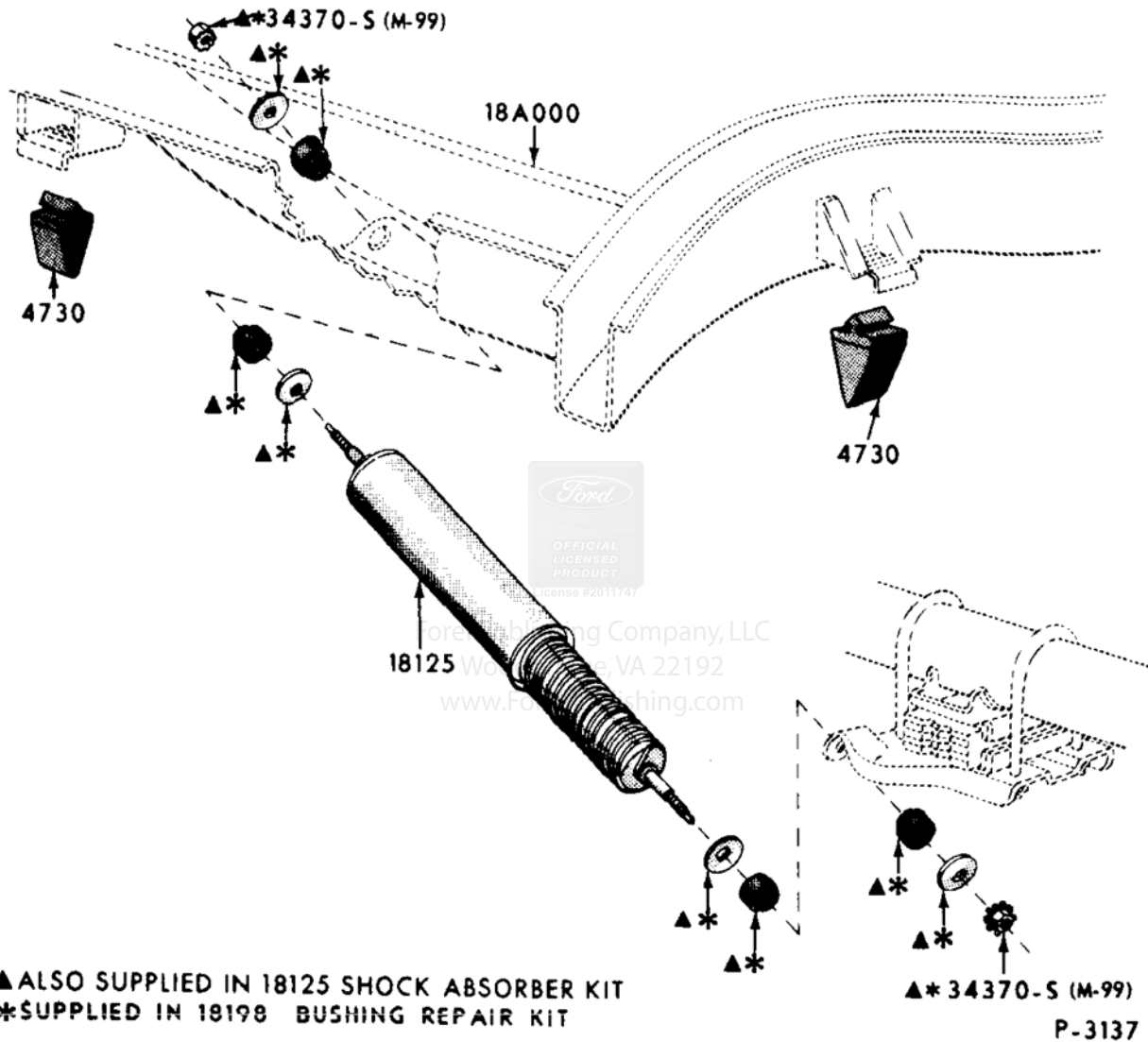

**SHOCK ABSORBER - REAR
1965 / 68 FALCON AND MUSTANG**

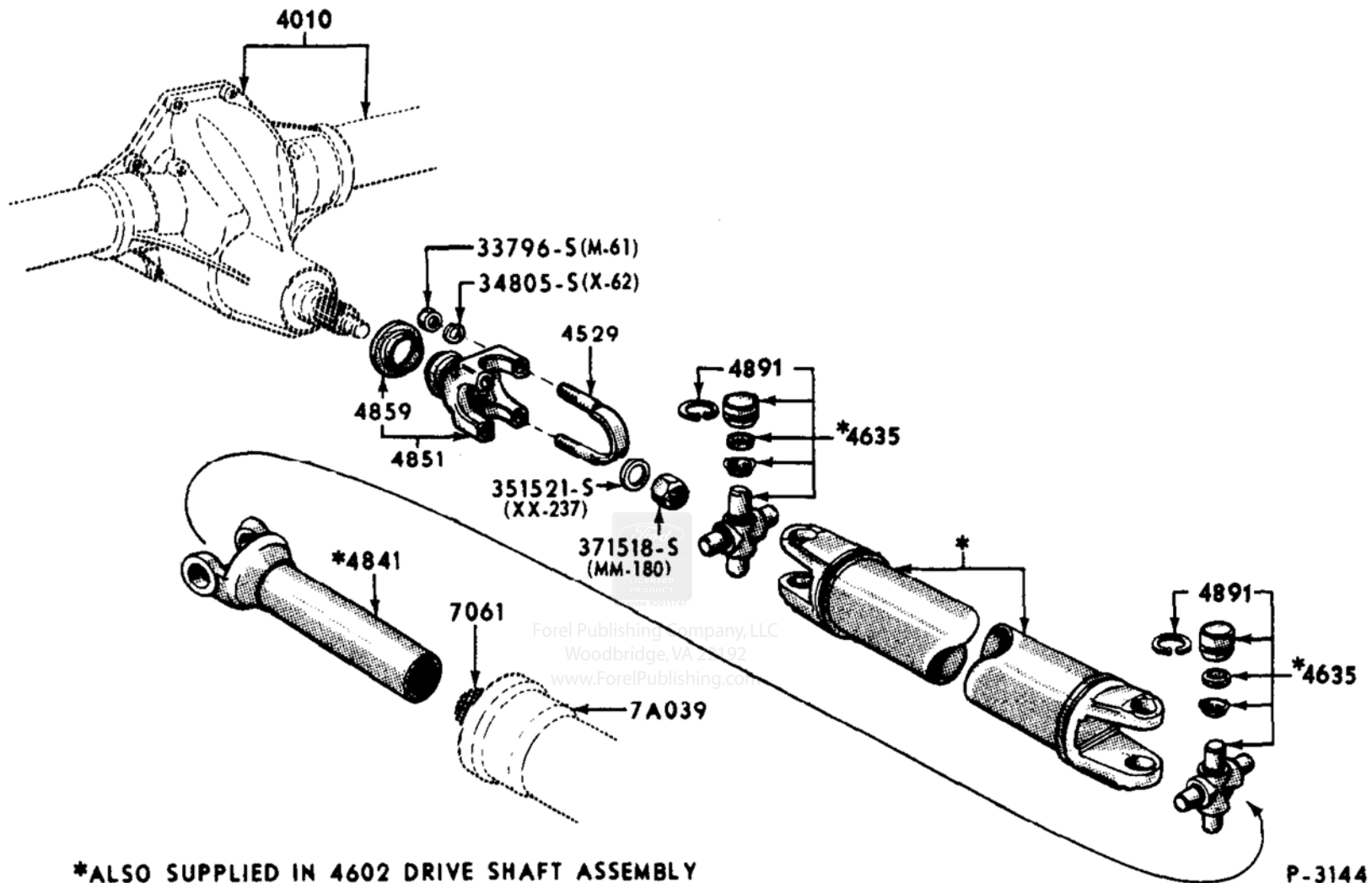

DRIVE SHAFT - TYPICAL
1965/72 MUSTANG, FAIRLANE/TORINO & 1965/70 FALCON
1970/72 MAVERICK, 1971/72 PINTO

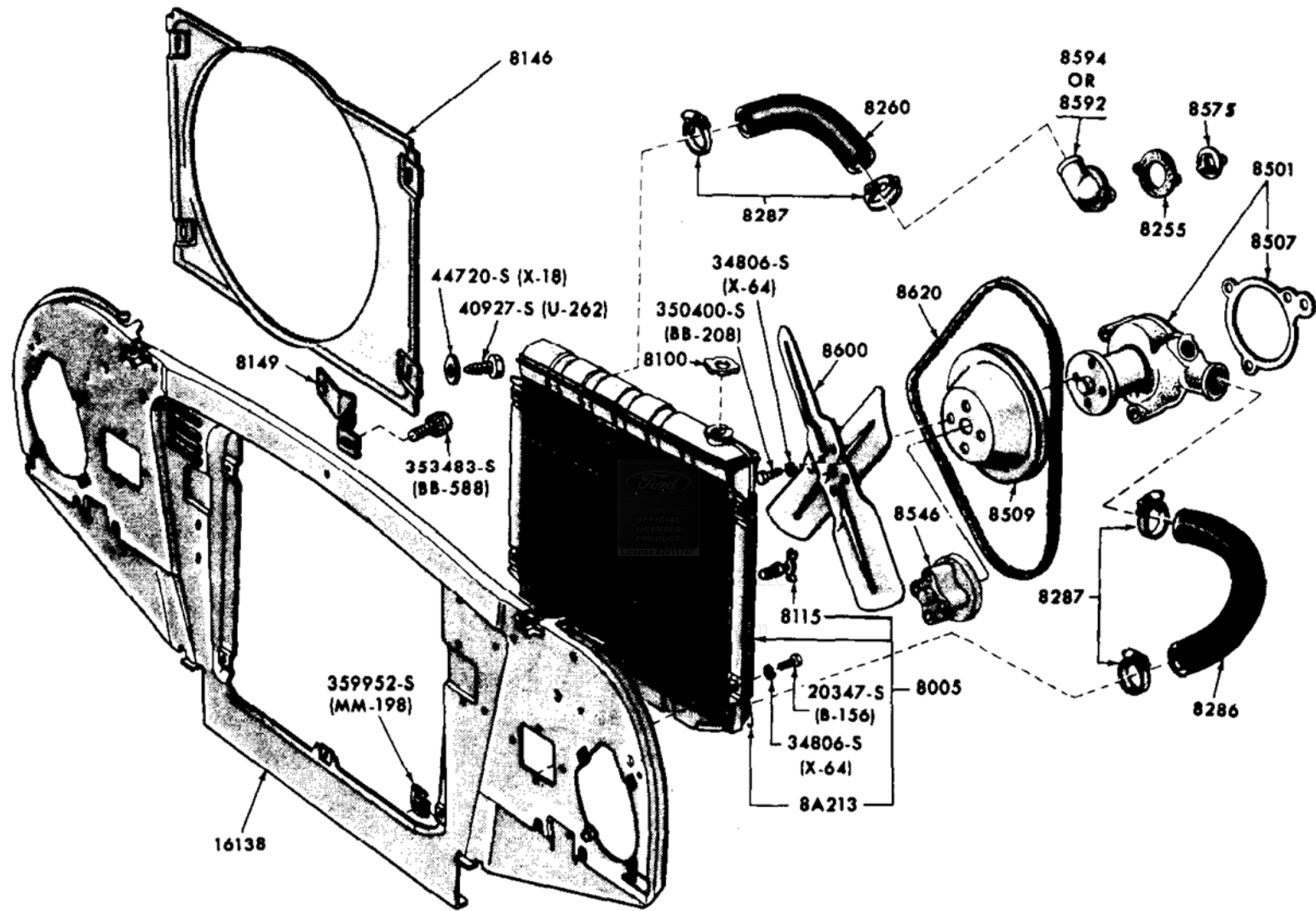

P-3147

COOLING SYSTEM AND RELATED PARTS - TYPICAL
1965 / 72 FALCON, MAVERICK, MUSTANG - 6 CYLINDER 170, 200, 250, AND 8 CYLINDER 260, 289, 302 & 351
1966 / 72 BRONCO - 6 CYLINDER 170

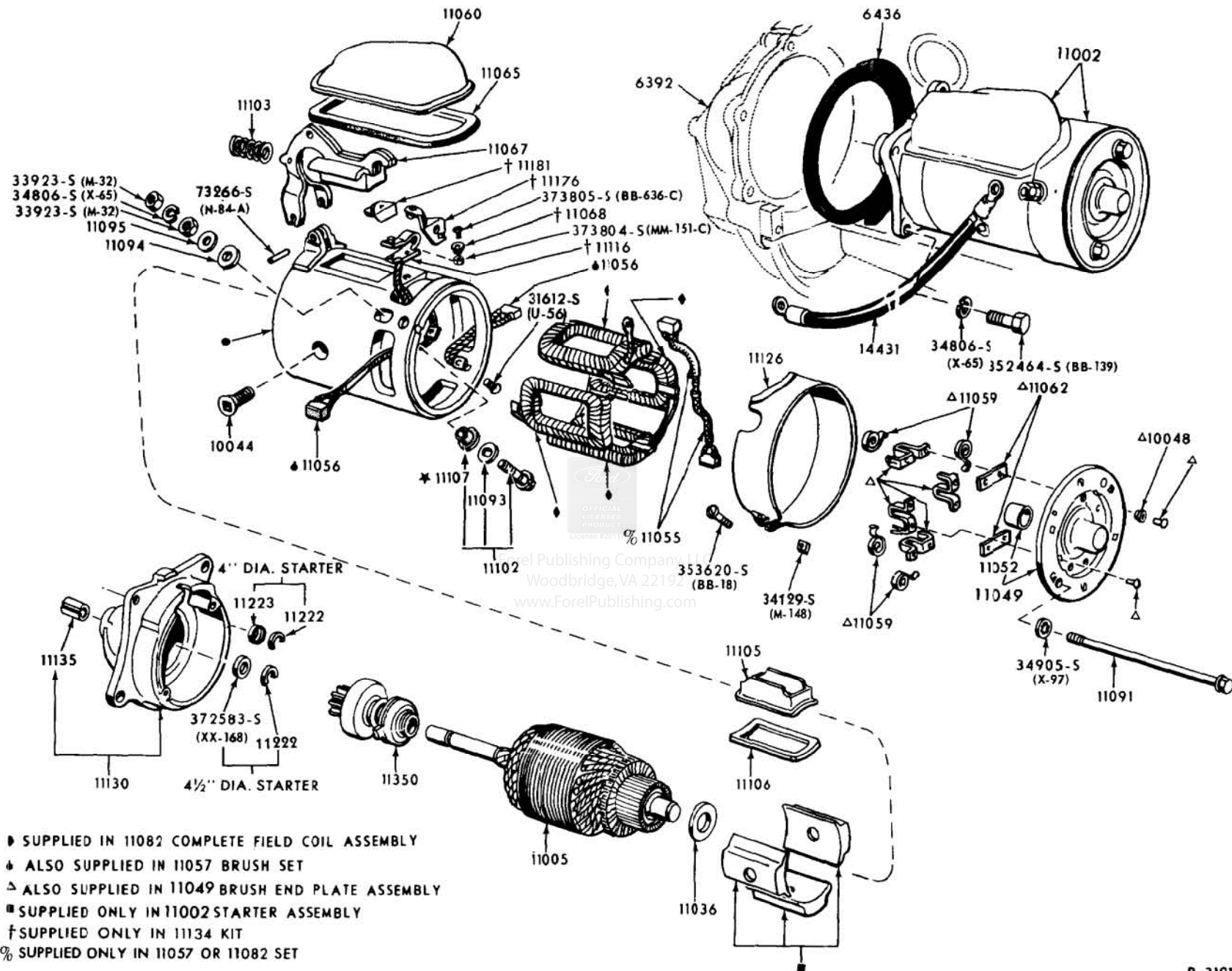

STARTER AND DRIVE ASSY. - POSITIVE ENGAGEMENT
1965 / 72

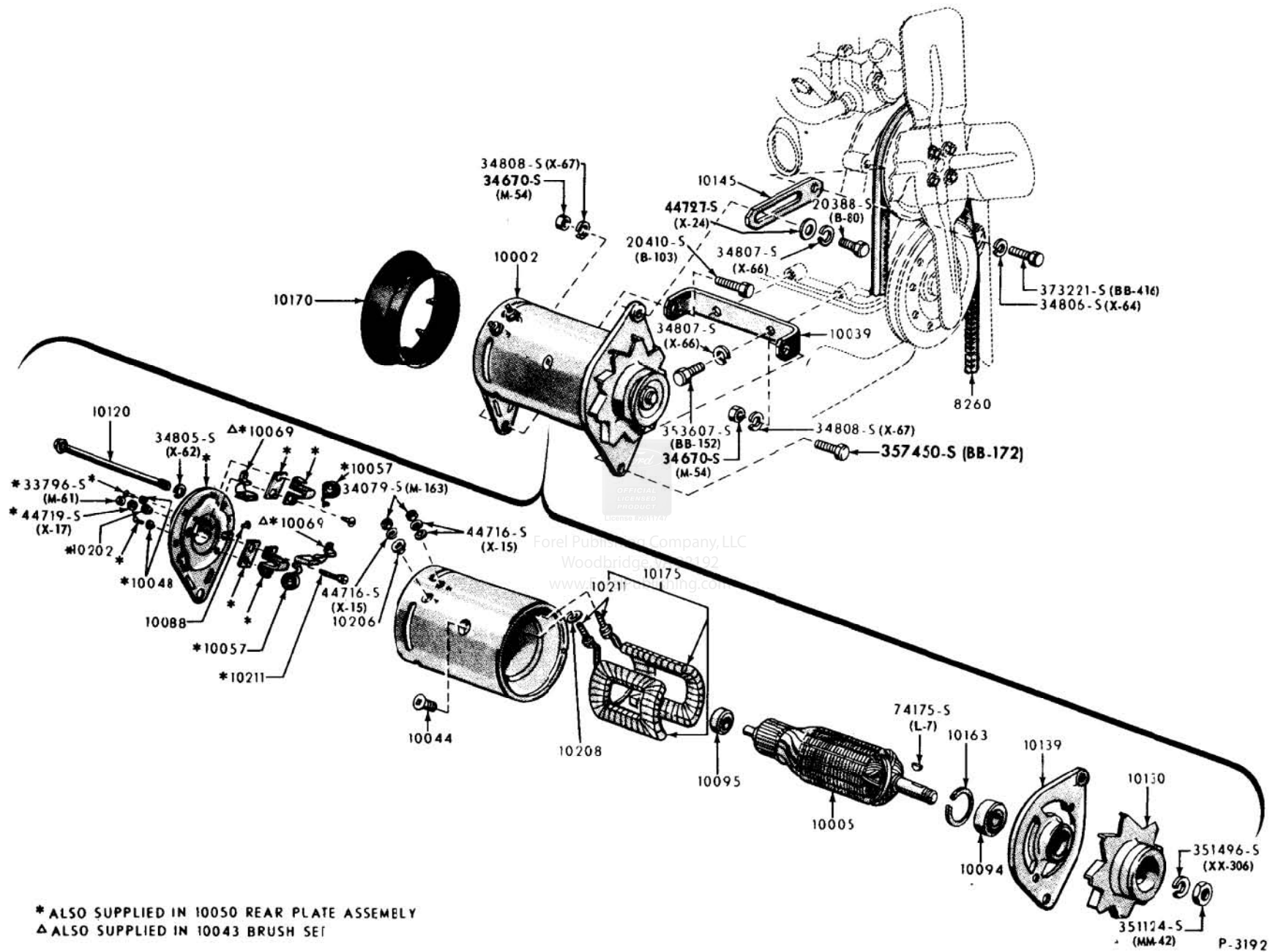

**GENERATOR AND RELATED PARTS (FORD 15-VOLT - 25, 30 AMP.)
 1965 MUSTANG**

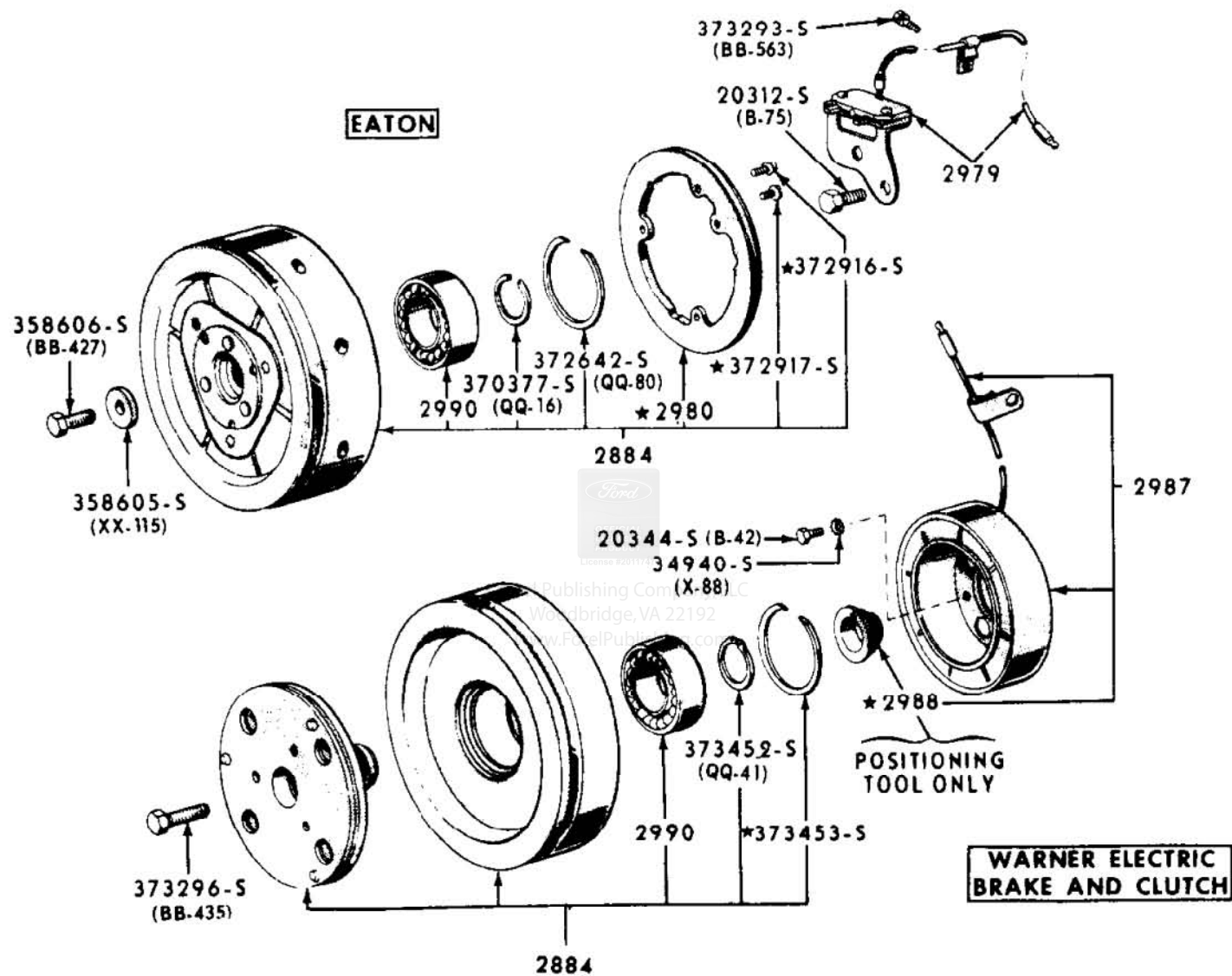

P-3216

**CLUTCHES AND RELATED PARTS - AIR CODITIONER COMPRESSOR
1965 / 72 - ALL - INTEGRAL A / C**

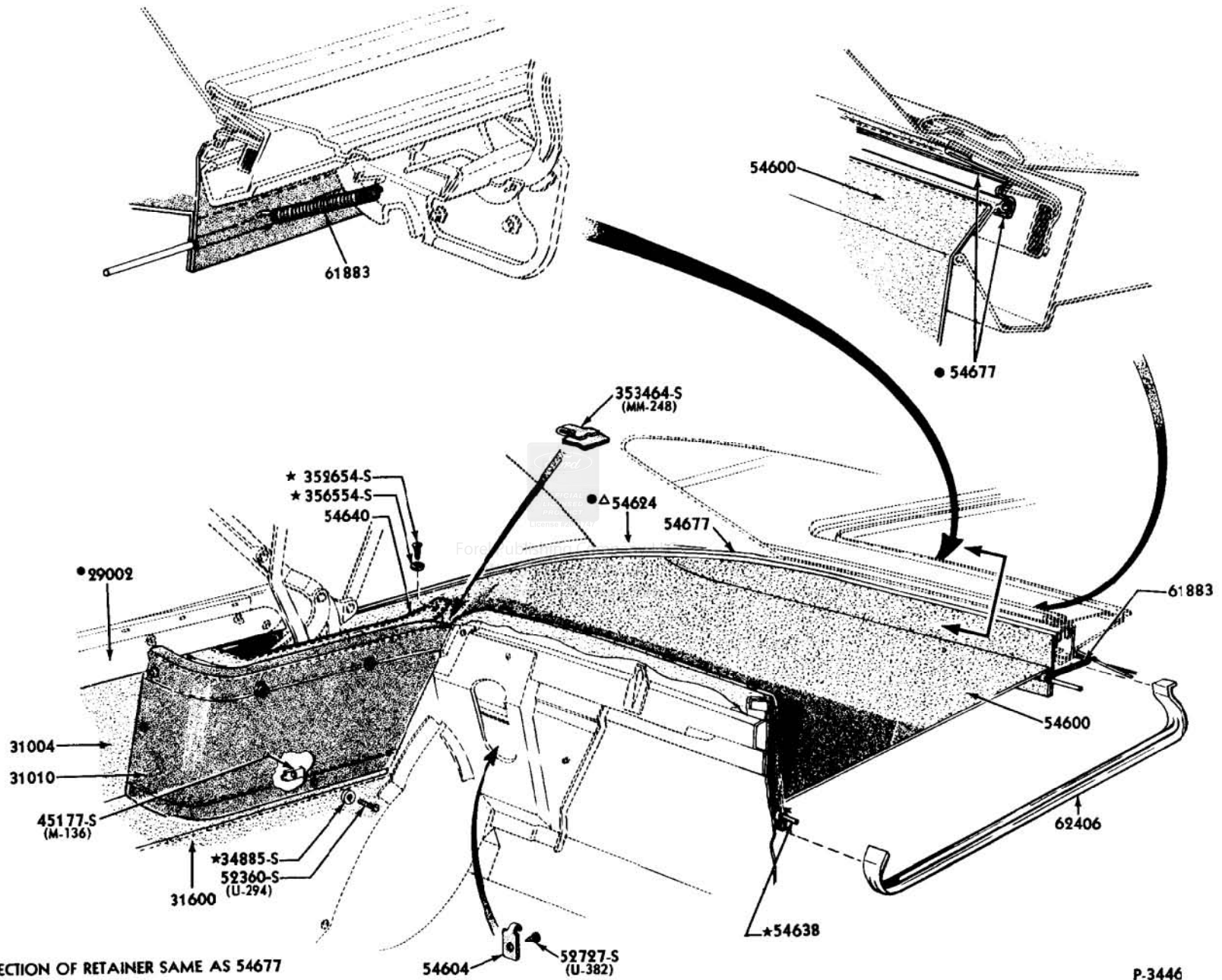

Δ CROSS SECTION OF RETAINER SAME AS 54677
 ● REFER TO GROUP IN BODY SECTION

P-3446

FOLDING TOP COMPARTMENT TRIM AND RELATED PARTS
1965 / 66 MUSTANG - BODY TYPE 76

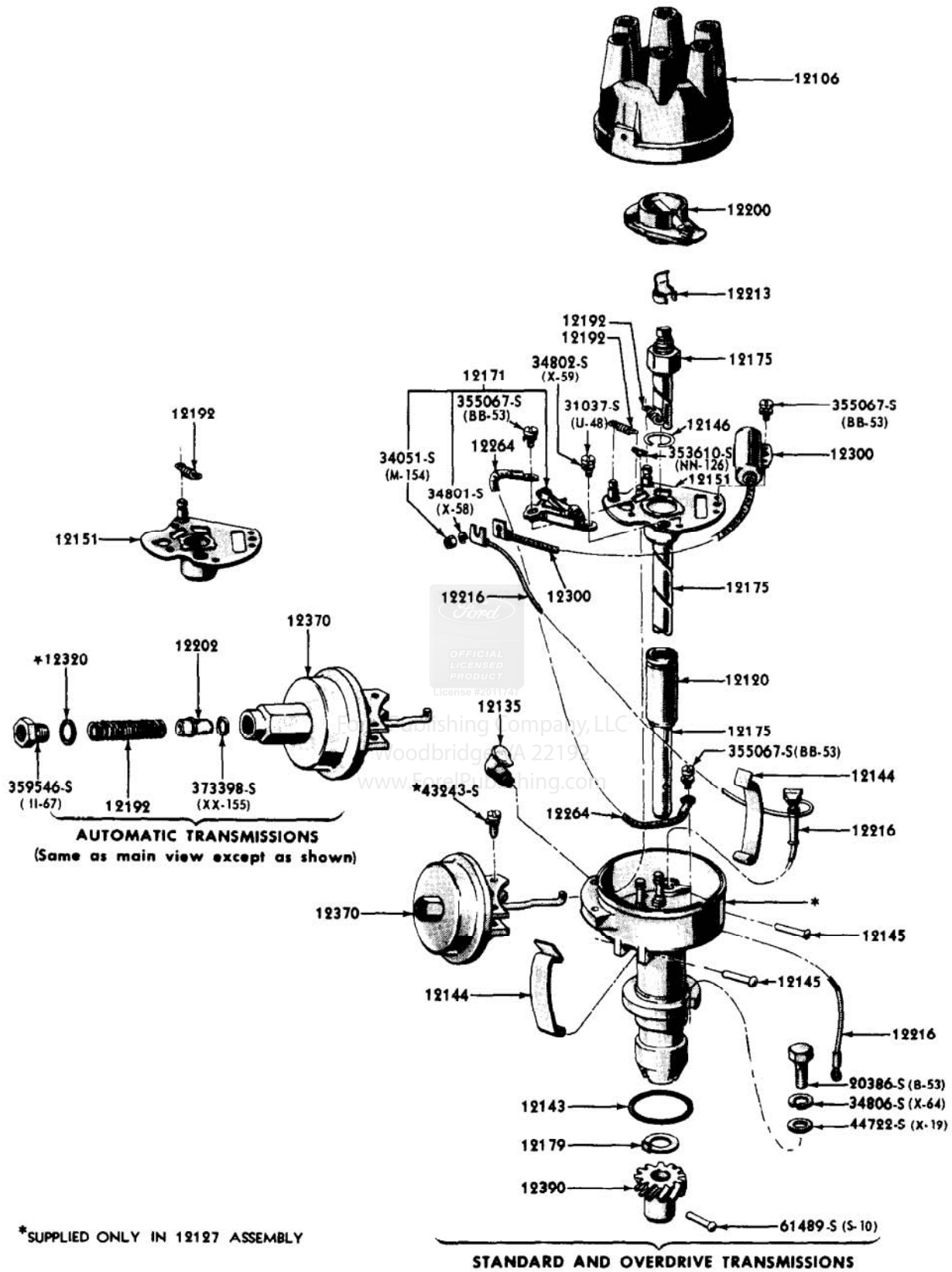

*SUPPLIED ONLY IN 12127 ASSEMBLY

P-3475

DISTRIBUTOR
1965 / 67 6 CYLINDER 240 ENGINES

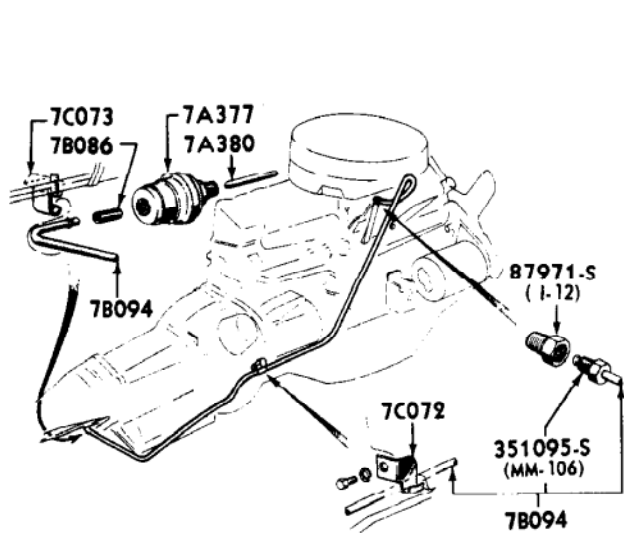

6 CYLINDER 200 & 250 ENGINES

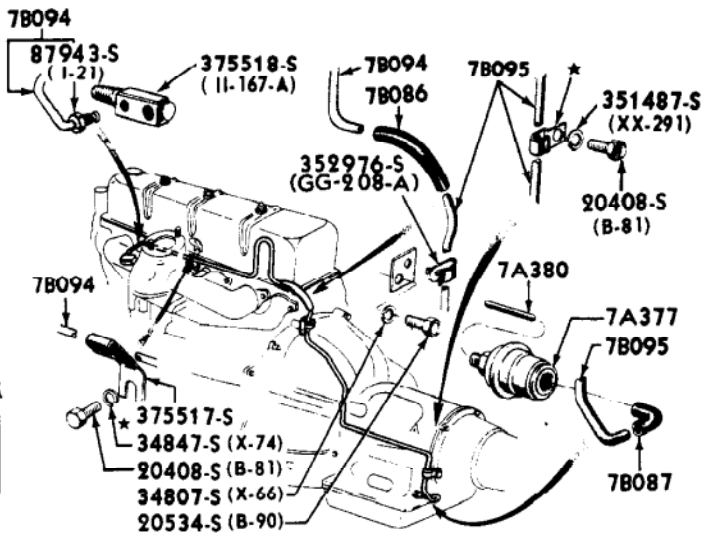

6 CYLINDER 240 ENGINE

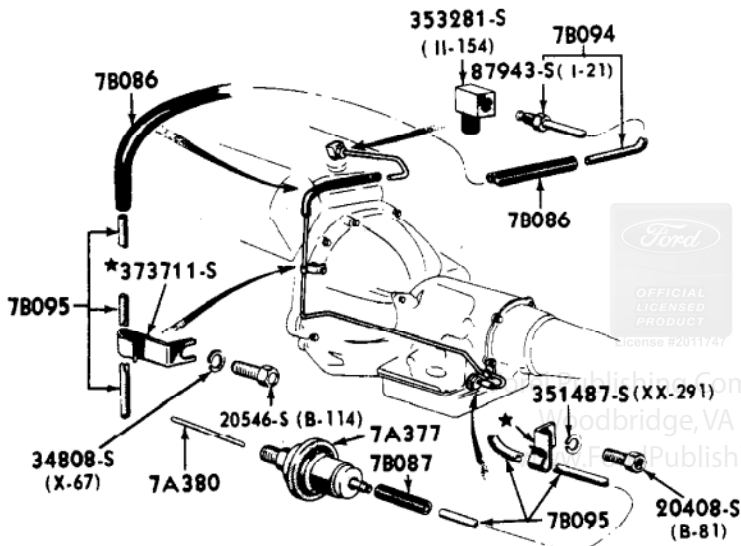

8 CYLINDER 400, 429 & 460 ENGINES WITH C/M & C/6 TRANSMISSIONS

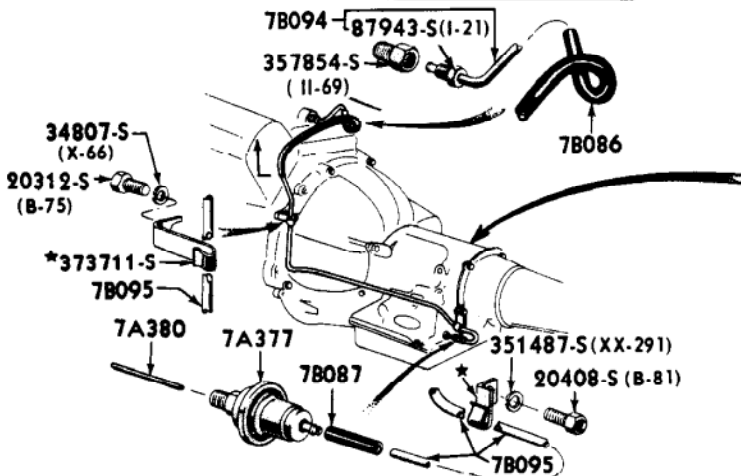

8 CYLINDER 302 & 351 ENGINES WITH C/M & C4 TRANSMISSIONS

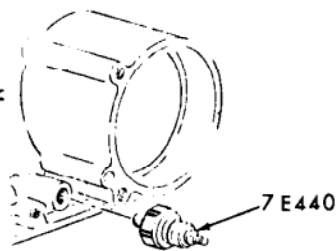

C4 TRANS ONLY

**VACUUM THROTTLE VALVE, LINES & FITTINGS - TYPICAL
1965 / 72 FORD, FAIRLANE / TORINO, MUSTANG, THUNDERBIRD & FALCON**

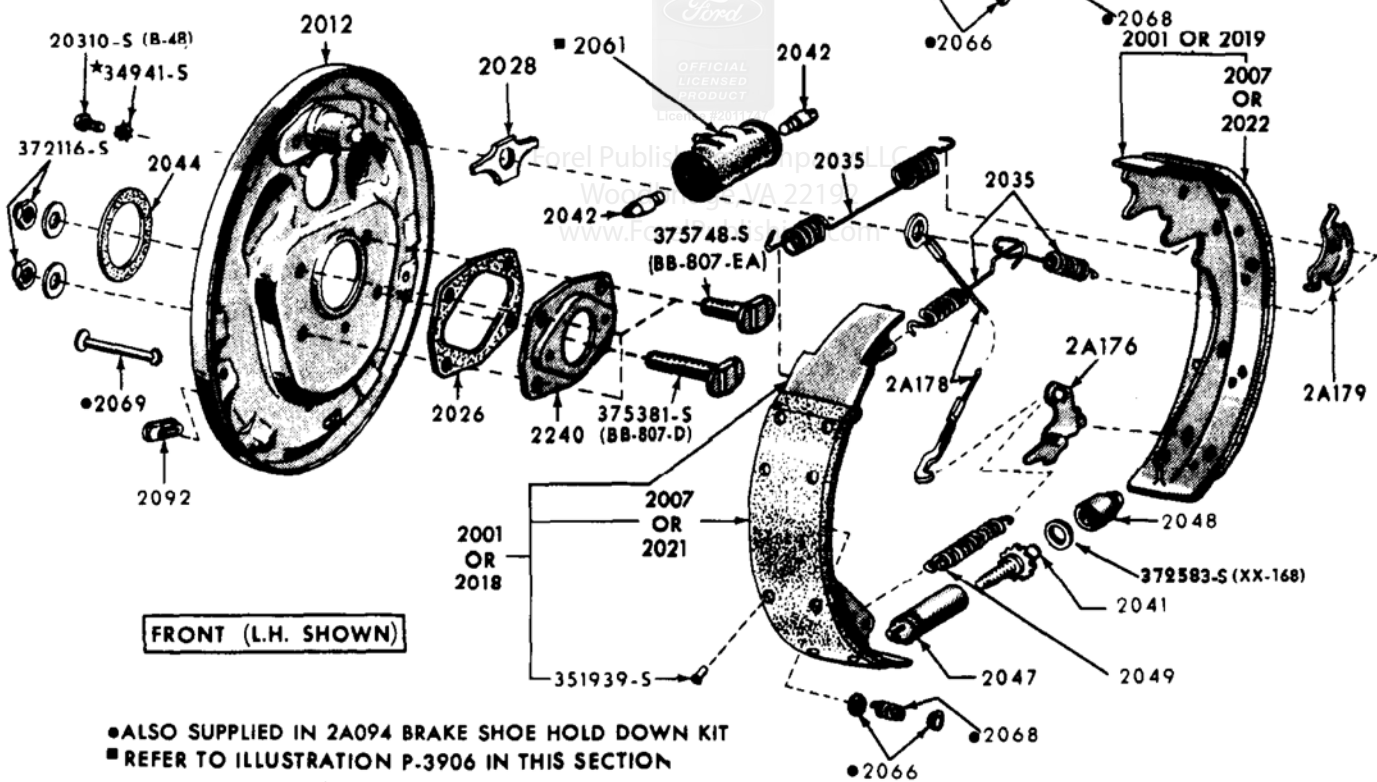
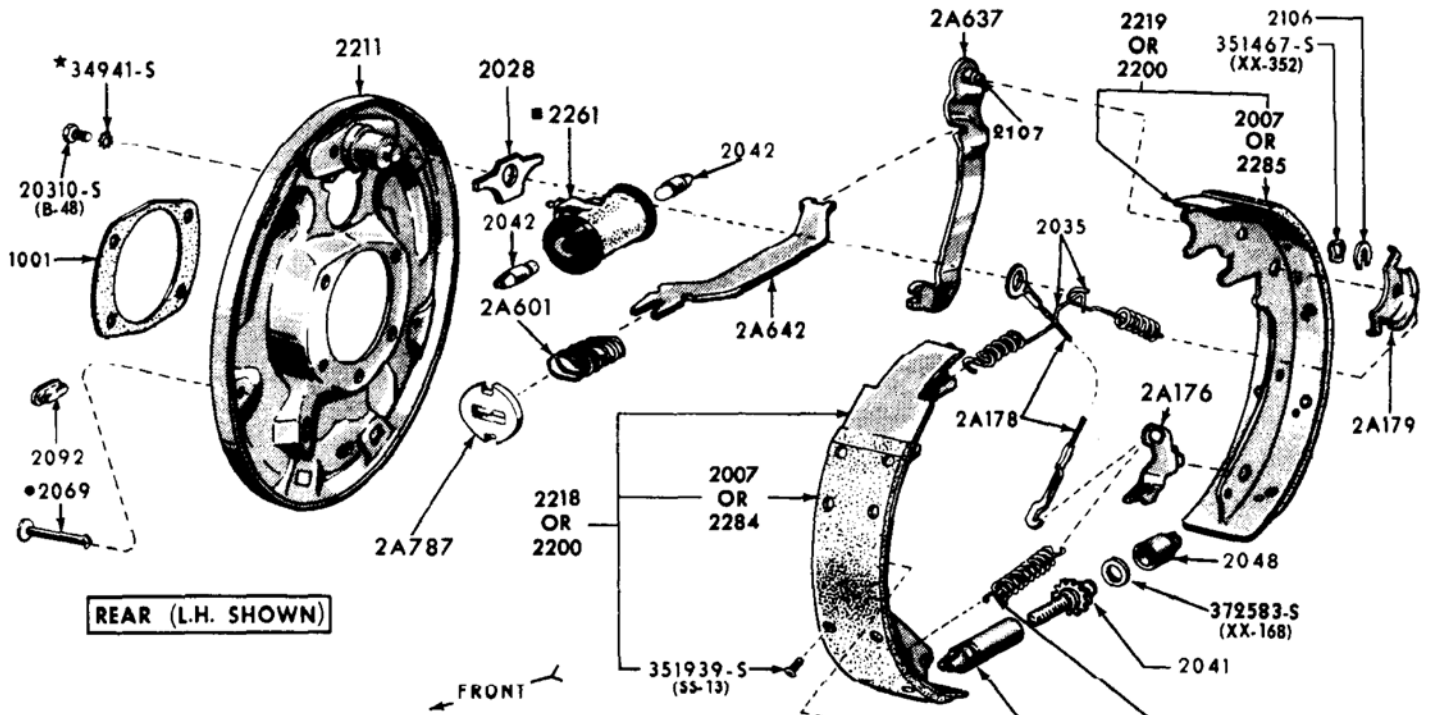

● ALSO SUPPLIED IN 2A094 BRAKE SHOE HOLD DOWN KIT
 ■ REFER TO ILLUSTRATION P.3906 IN THIS SECTION
 FOR DETAIL PARTS

FRONT & REAR DRUM BRAKES
1965 / 72 MUSTANG / FAIRLANE / TORINO
1965 / 70 FALCON, 1970 / 72 MAVERICK, 1971 / 72 PINTO

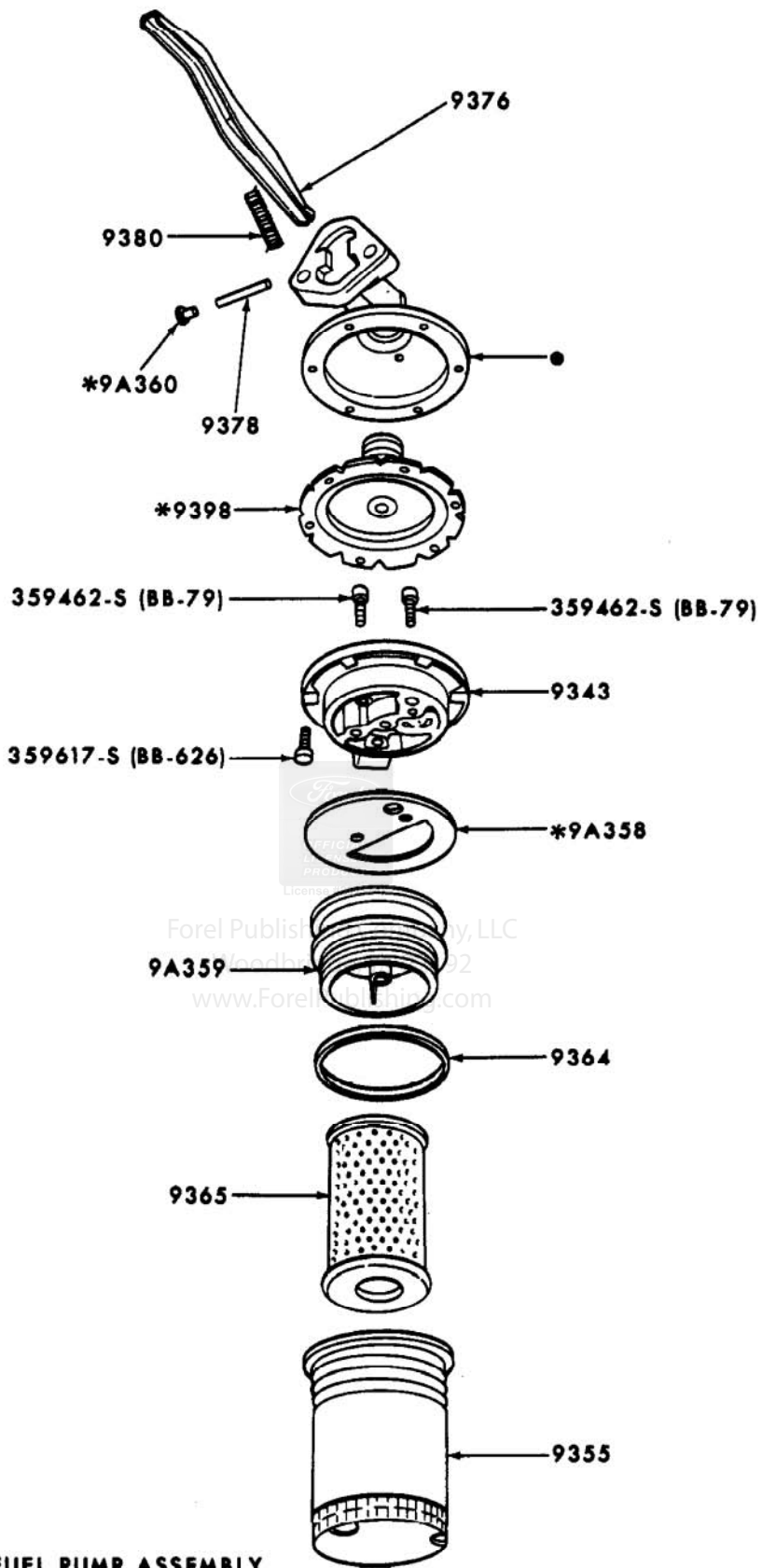

● SUPPLIED IN 9350 FUEL PUMP ASSEMBLY
 *ALSO SUPPLIED IN 9349 REPAIR KIT

P-3715

FUEL PUMP AND FILTER
 1965 (8 CYLINDER 260, 289, 352, 390 ENGINES EXCEPT SPECIAL)
 1966 THUNDERBIRD (8 CYLINDER 390, 428 ENGINES)

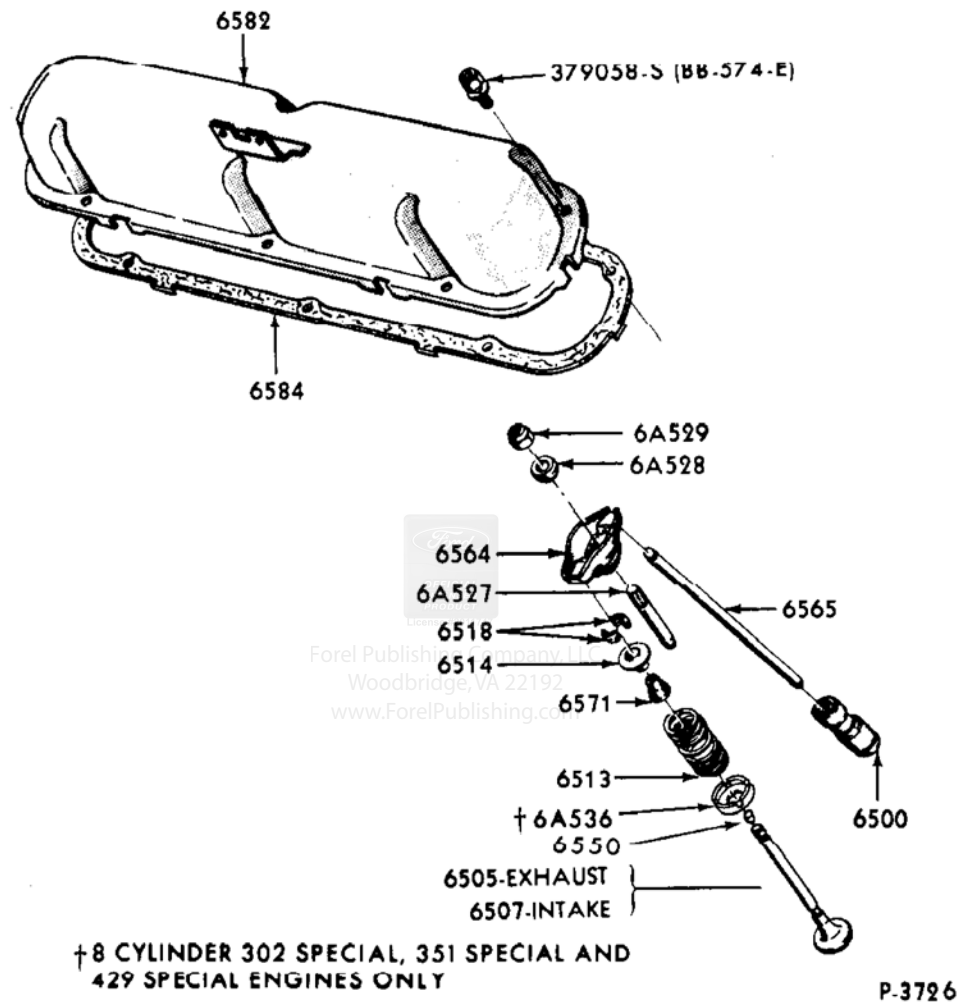

**ENGINE VALVES, PUSH RODS, ROCKER ARM COVER AND RELATED PARTS -- TYPICAL
1965/72 6 CYLINDER 240 AND 8 CYLINDER 260, 289, 302, 351, 400, AND 420**

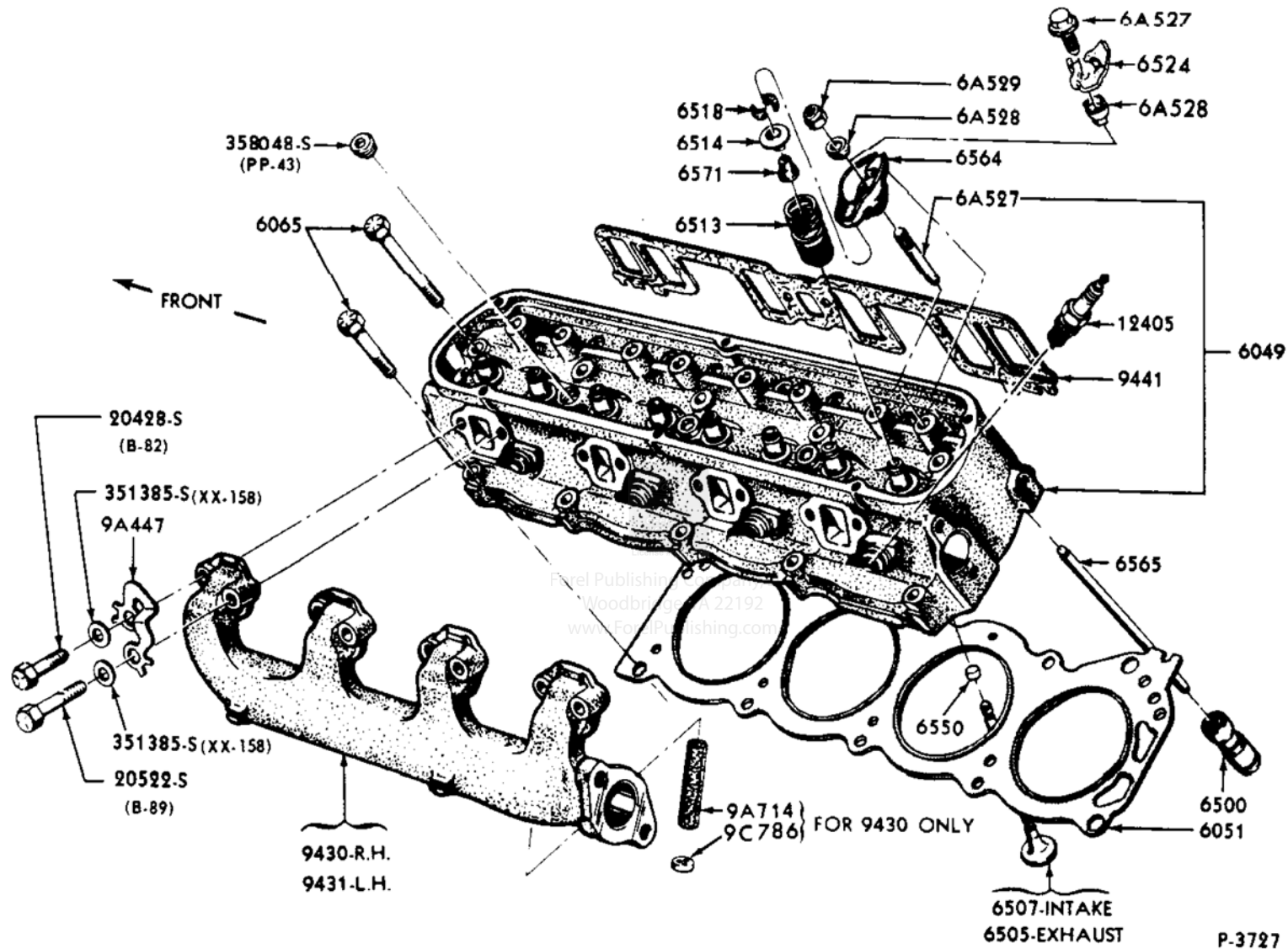

CYLINDER HEAD, VALVES AND RELATED PARTS
1965/72 8 CYLINDER 260, 289, 302, 351, 400, 429 AND 460 ENGINES -- TYPICAL

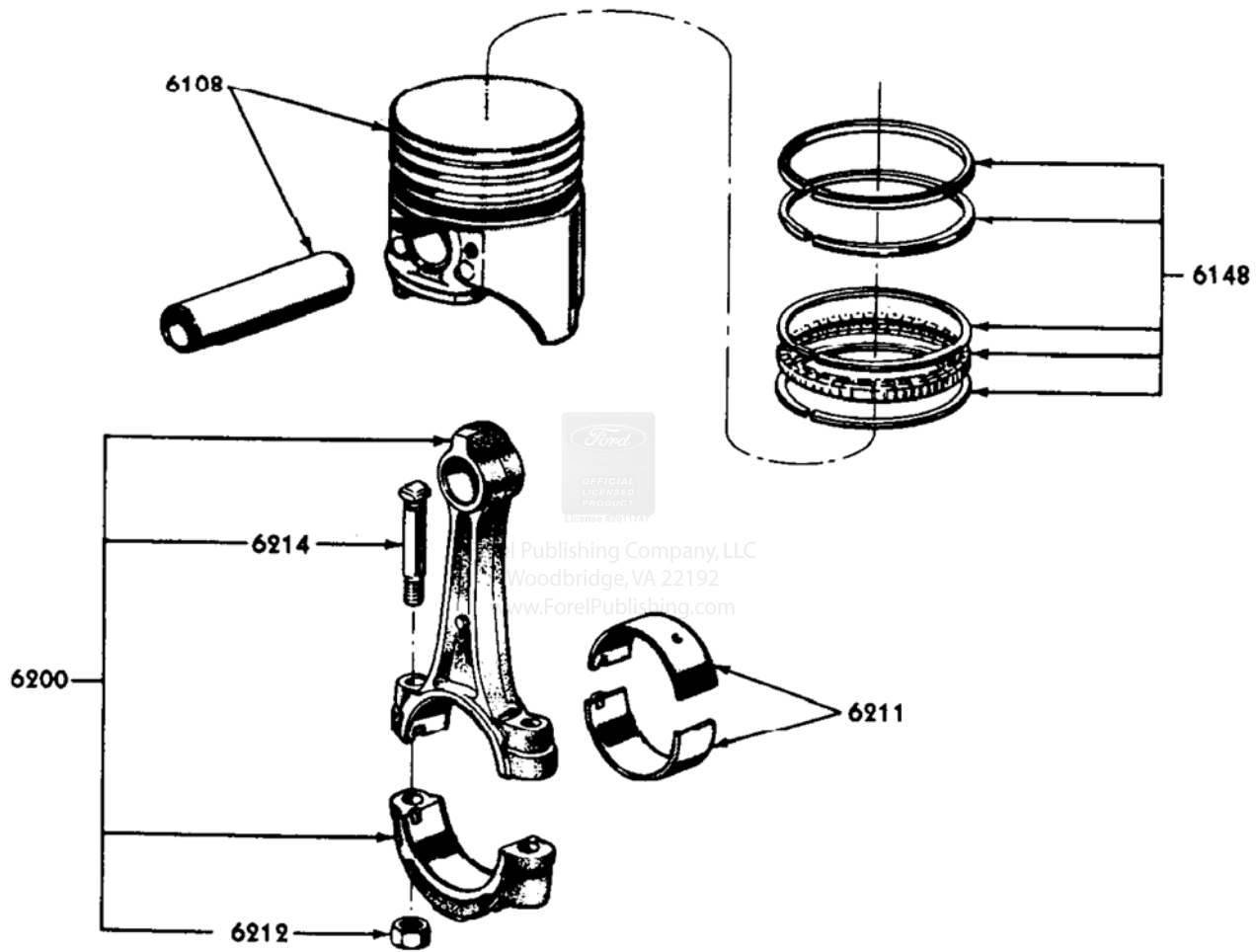

P. 3739

**ENGINE PISTON, CONNECTING ROD AND RELATED PARTS -- TYPICAL
1965/72 6 CYLINDER 240 AND 8 CYLINDER 260, 289, 302, 351, 400, 429 AND 460**

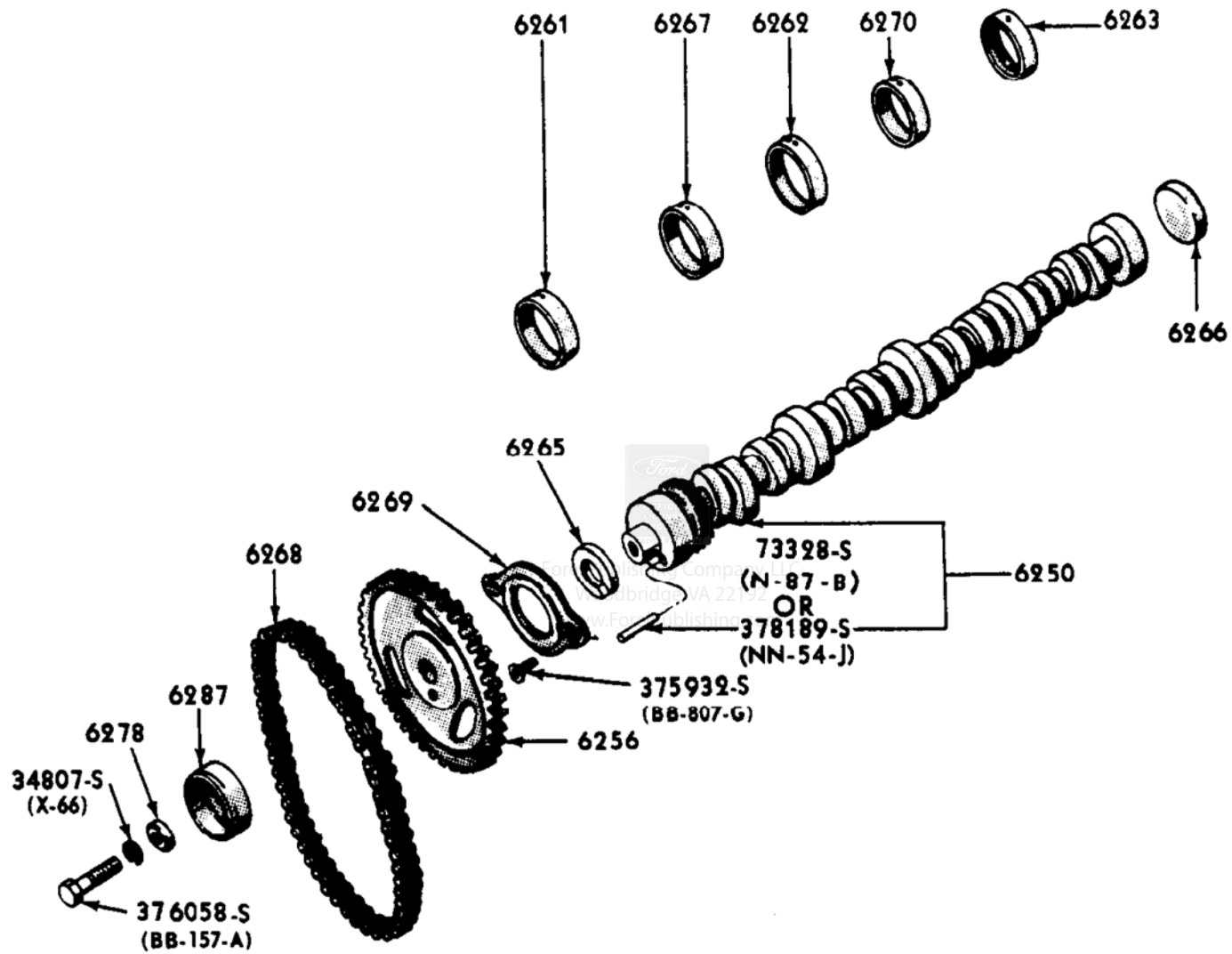

P-3733

ENGINE CAMSHAFT, GEAR, BEARINGS AND RELATED PARTS -- TYPICAL
 1966 / 72 8 CYLINDER 260, 289, 302, 351, 400, 429 AND 460

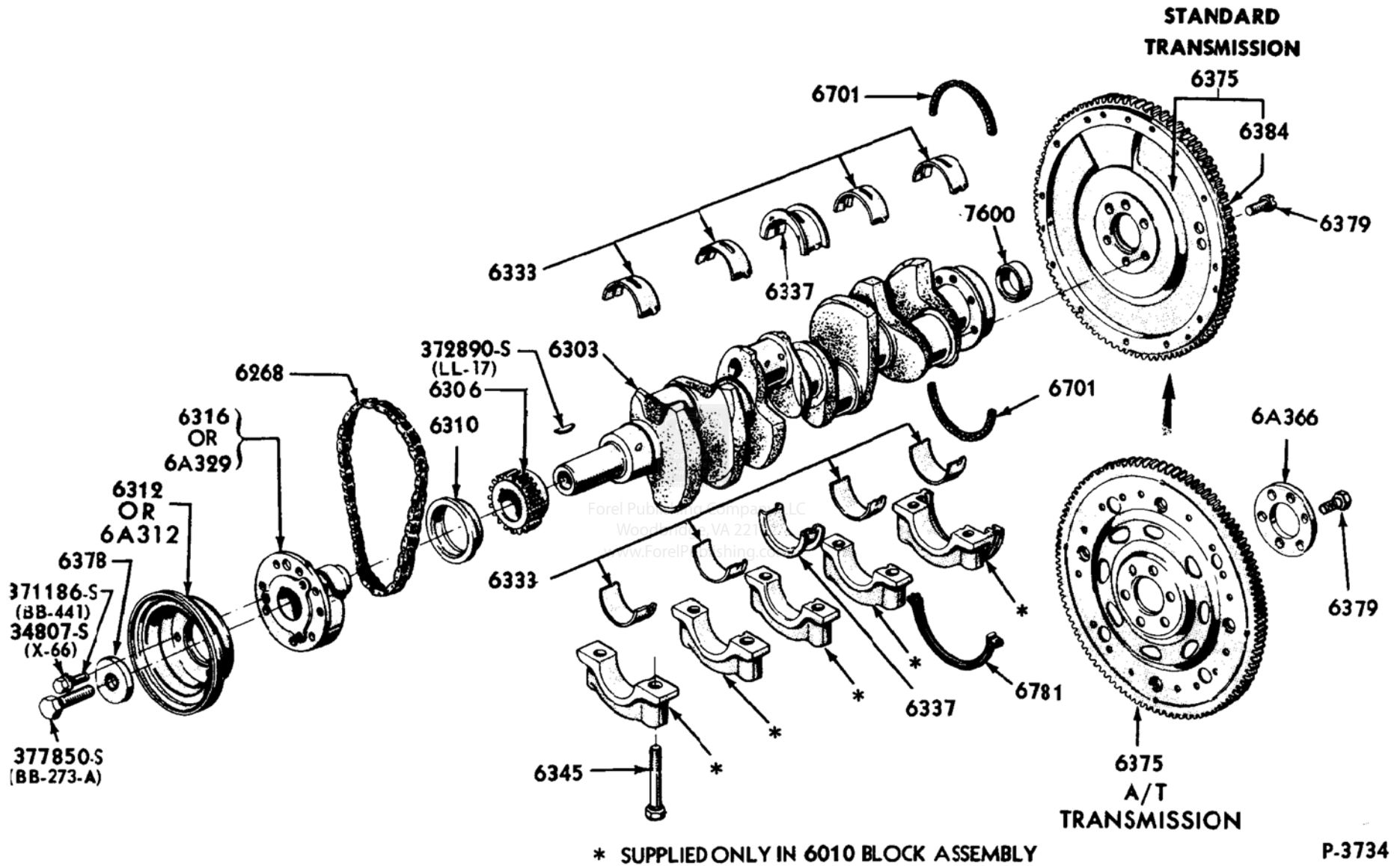

ENGINE CAMSHAFT, FLYWHEEL AND RELATED PARTS -- TYPICAL
1966 / 72 8 CYLINDER 260, 289, 302, 351, 400, 429 AND 460

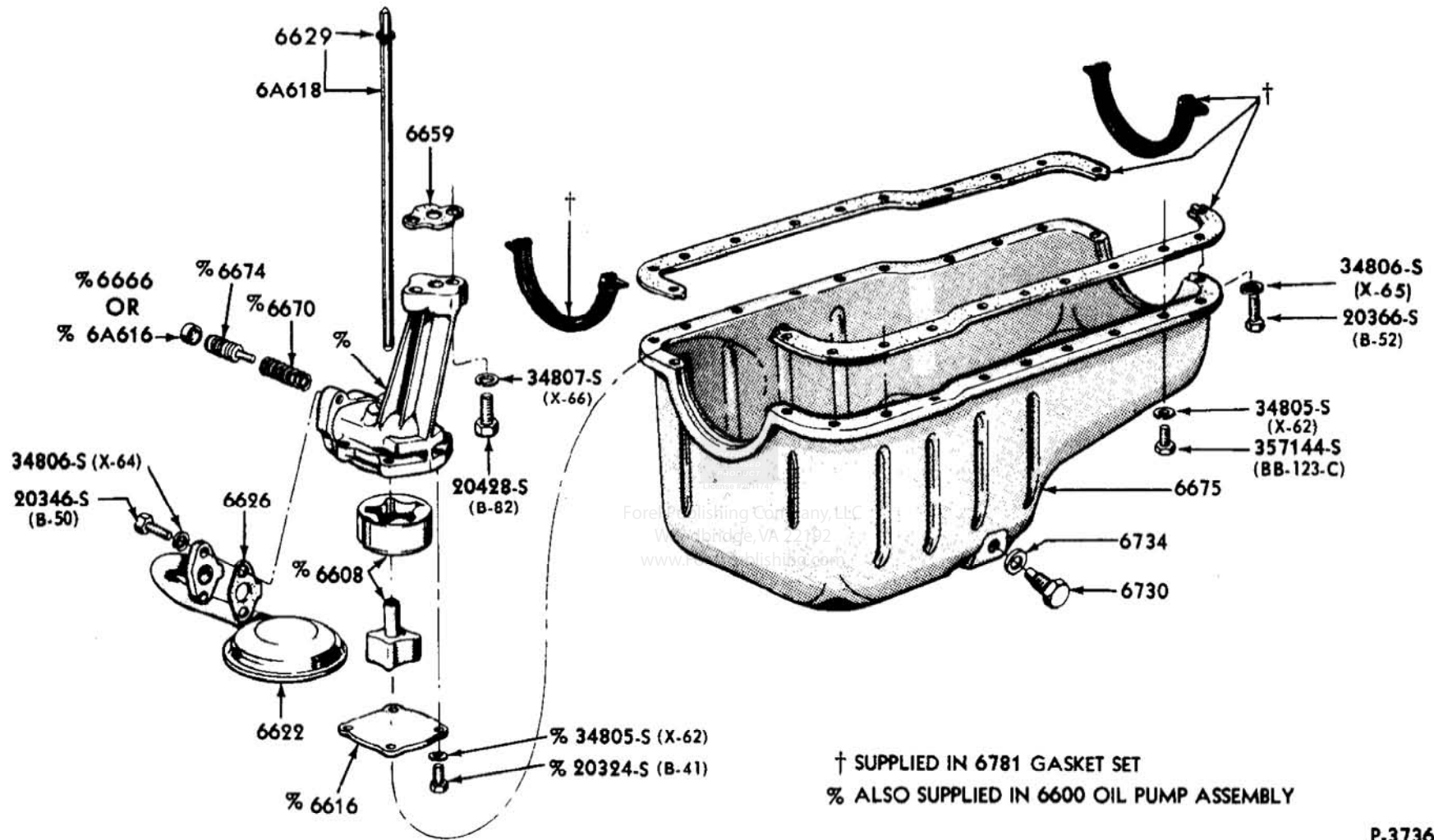

P-3736

**ENGINE OIL PUMP AND RELATED PARTS -- TYPICAL
 1965 / 72 8 CYLINDER 260, 289, 302, 351, 400, 429 AND 460**

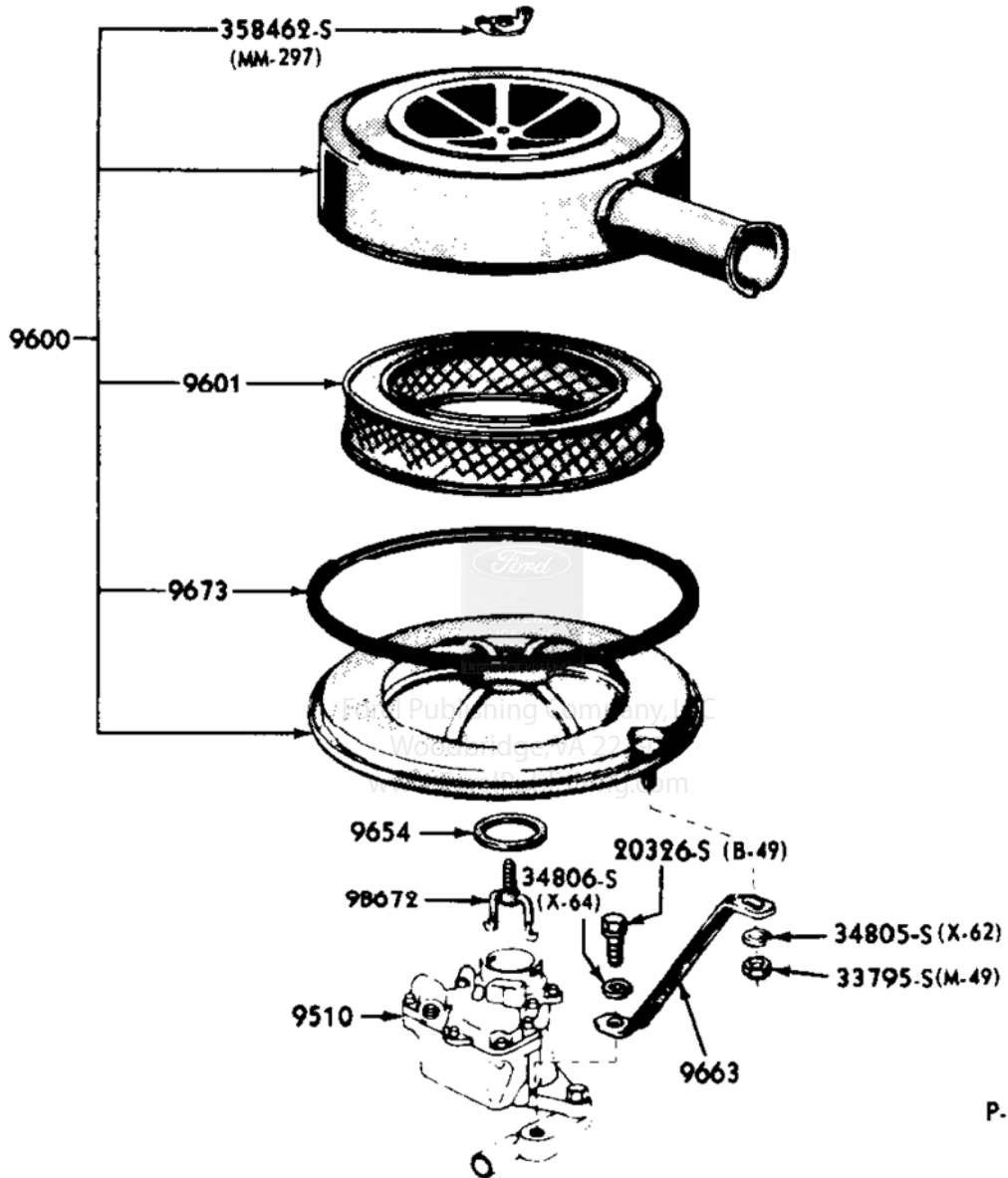

P-3737

AIR CLEANER - 6 CYLINDER
1965 / 67 FAIRLANE, FALCON AND MUSTANG
1966 BRONCO

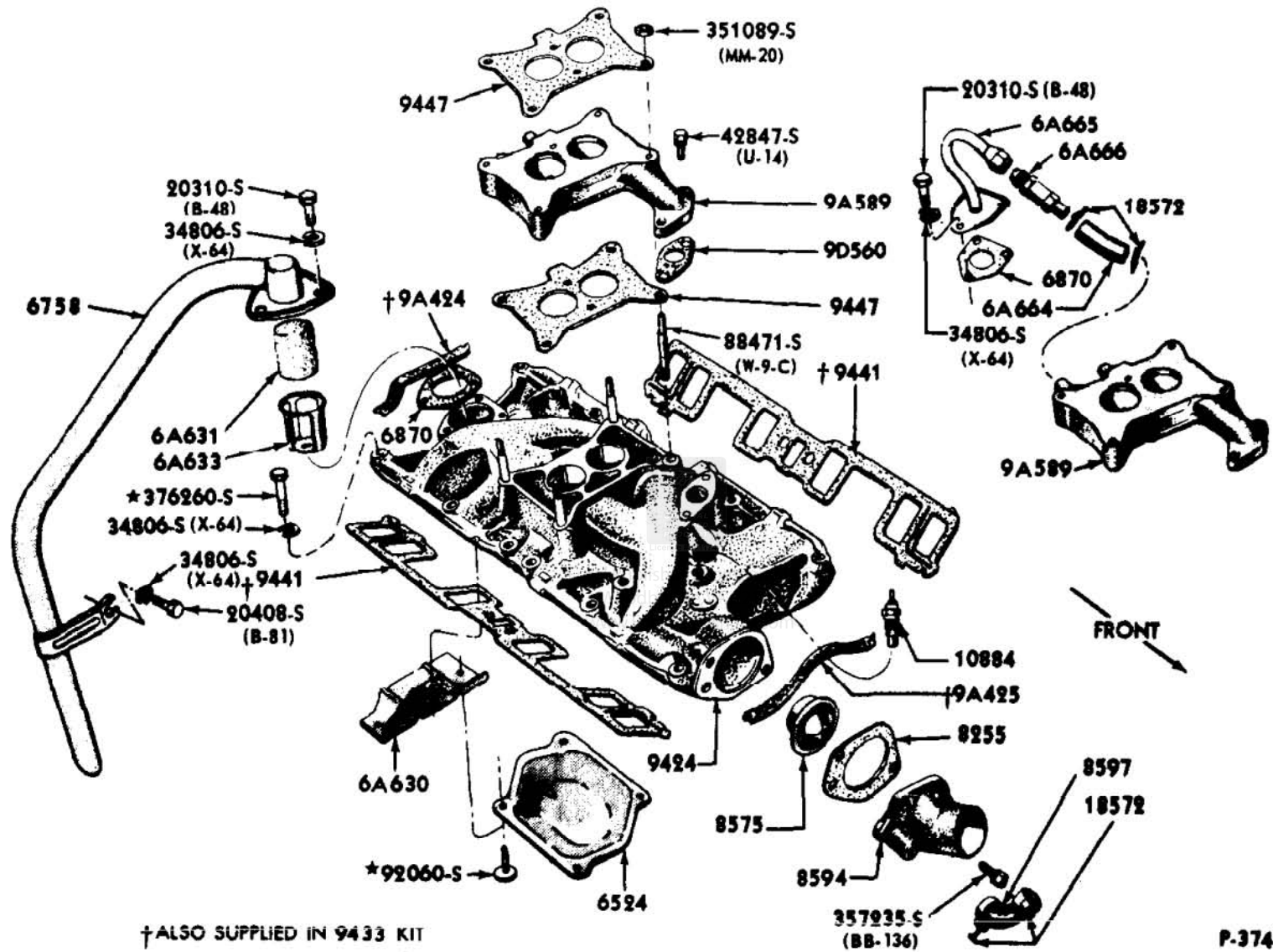

MANIFOLD AND RELATED PARTS - INTAKE
 1965 / 72 (8 CYLINDER 260, 289, 302, ENGINES) - TYPICAL

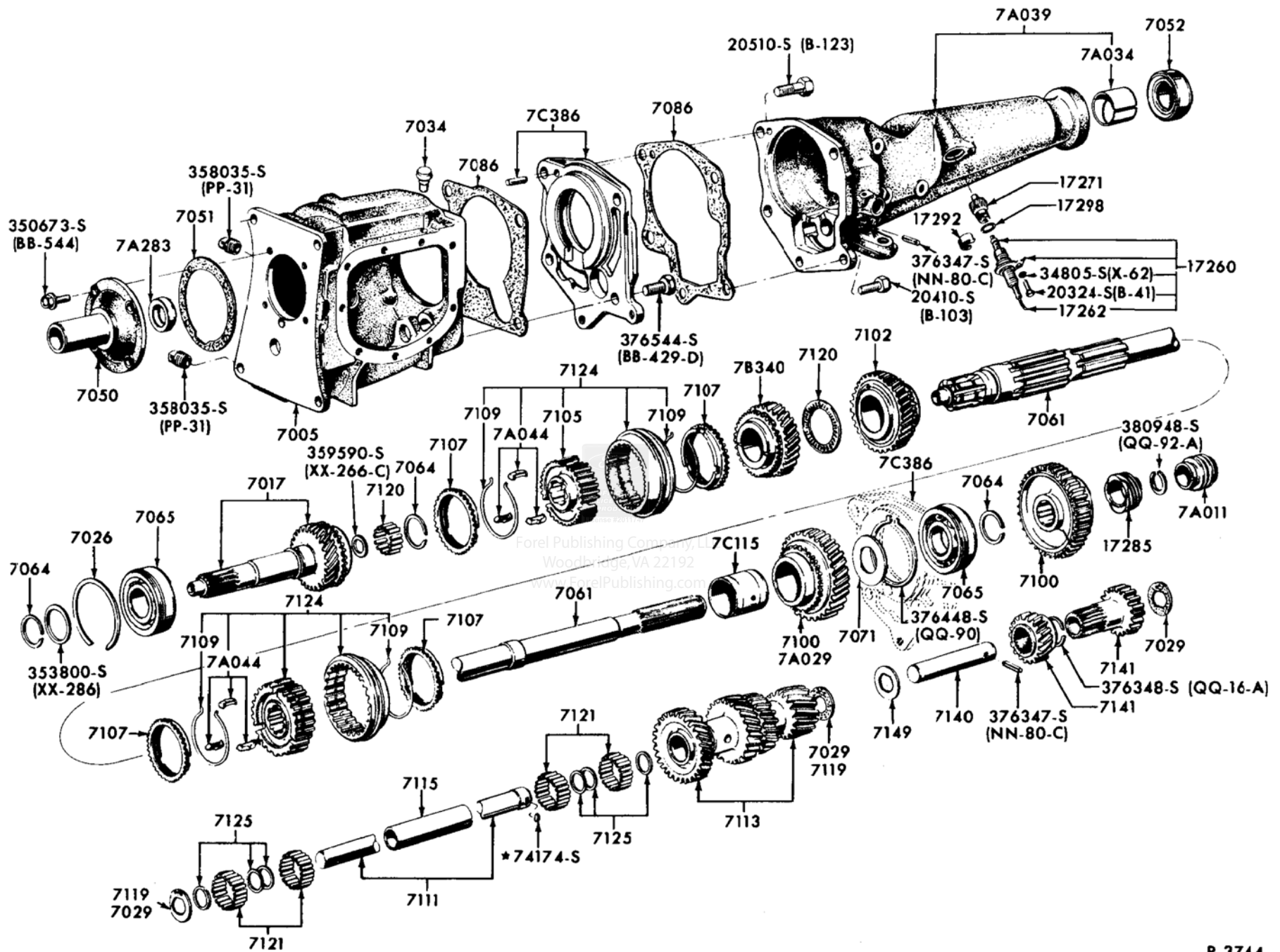

4 SPEED MANUAL TRANSMISSION - WARNER GEAR DESIGN
 1965 / 66 FAIRLANE, MUSTANG, FALCON

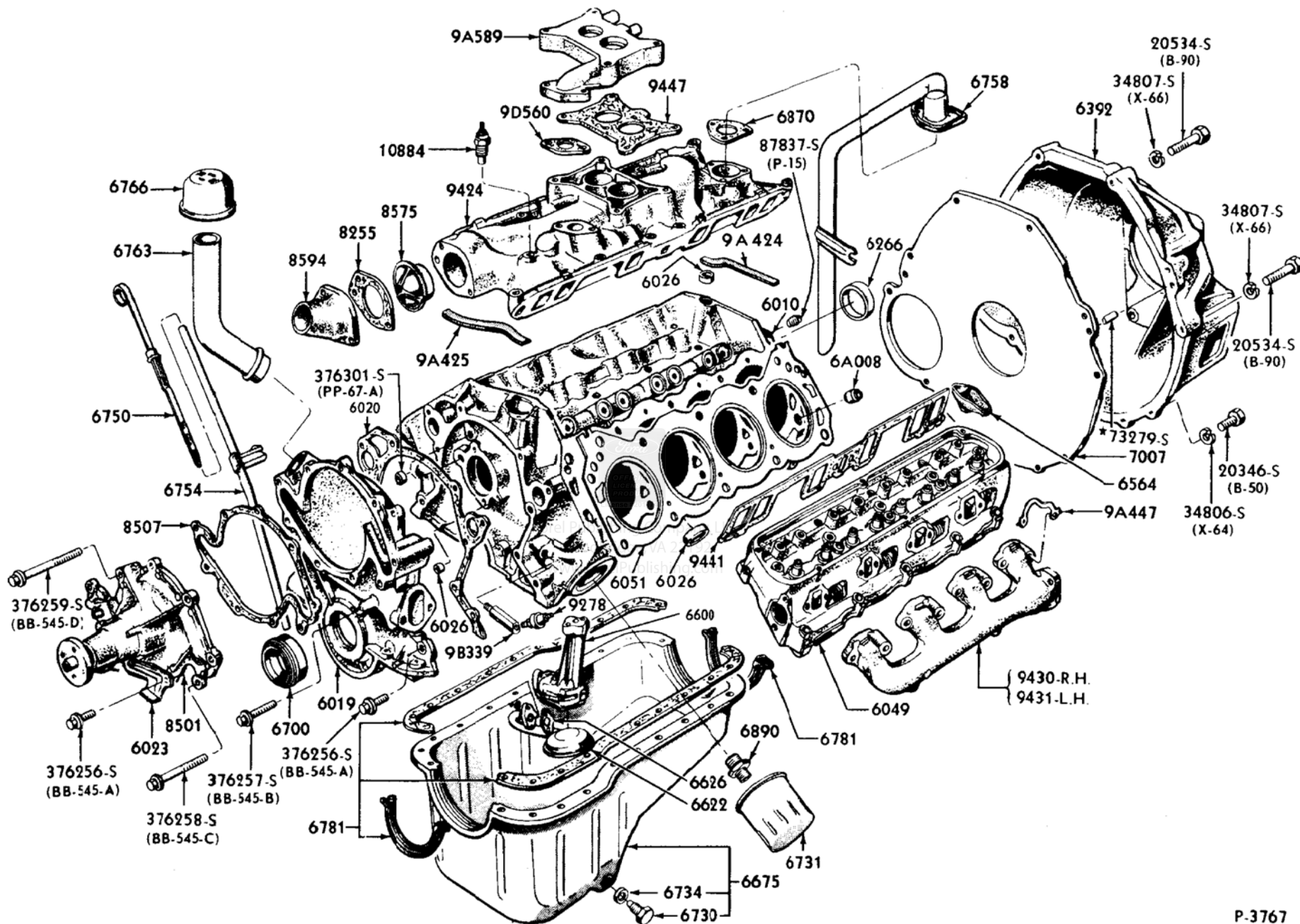

P-3767

**CYLINDER BLOCK AND RELATED PARTS -
 8 CYLINDER 260 AND 289 ENGINES -- TYPICAL**

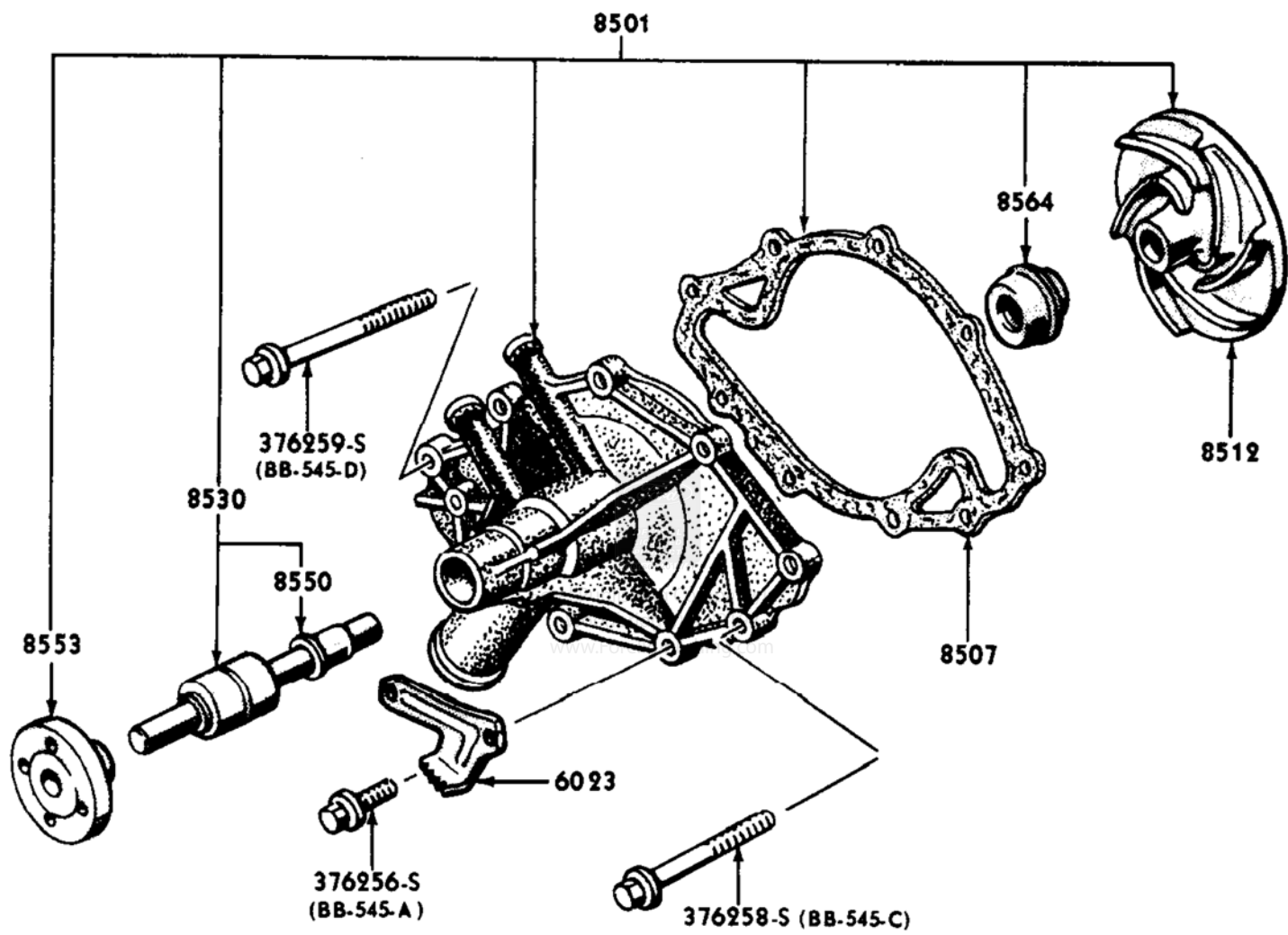

P-3772

WATER PUMP - WITHOUT COVER
 1965 8 CYLINDER 260 AND 289

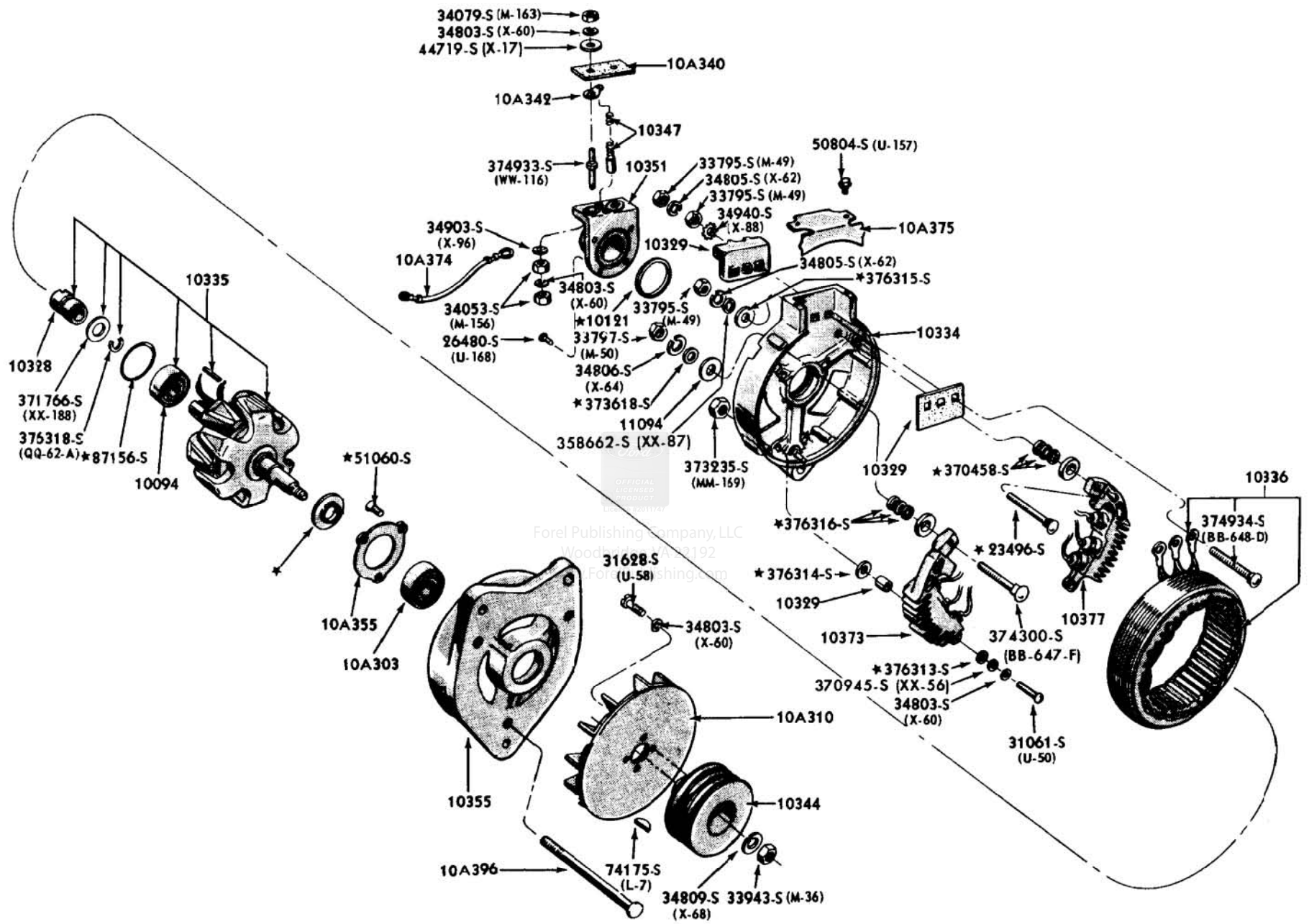

ALTERNATOR (LEECE NEVILLE 15 VOLT - 60, 65 AMP.)
 1965 / 67

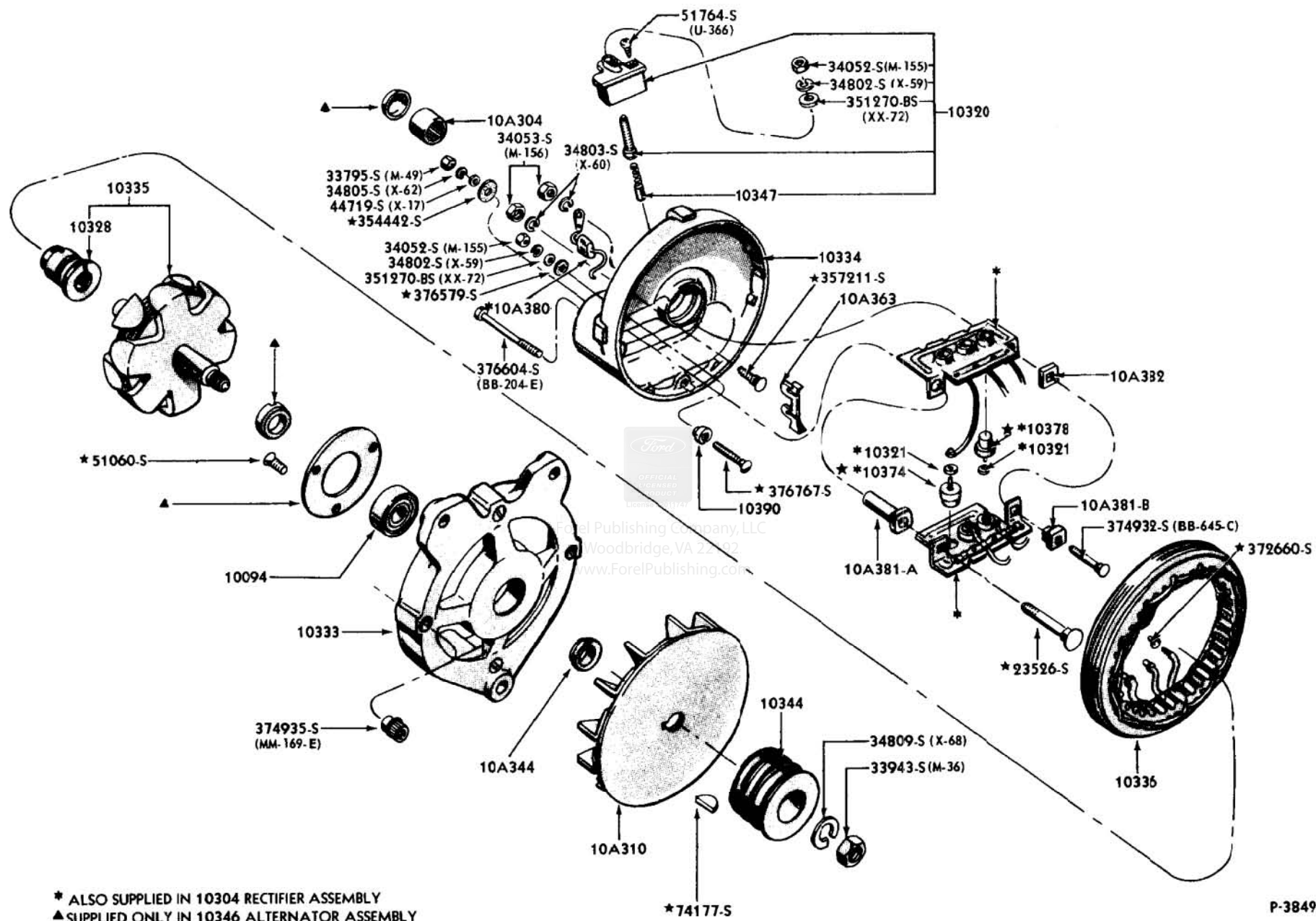

P-3849

ALTERNATOR (LEECE NEVILLE 15 VOLT - 40, 53 AMP.)

1965 / 67

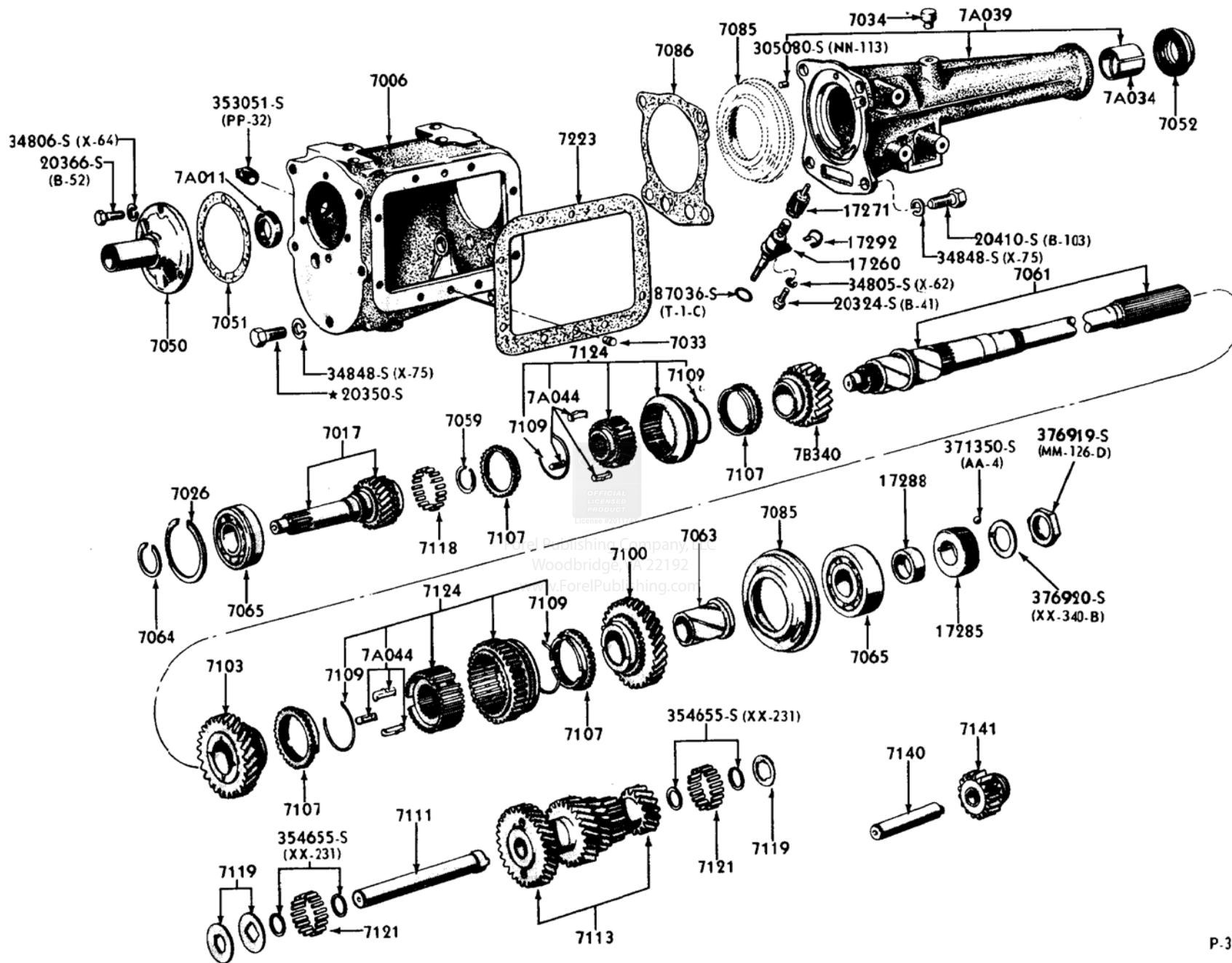

4 SPEED MANUAL TRANSMISSION - DAGENHAM DESIGN
 1965 / 66 MUSTANG

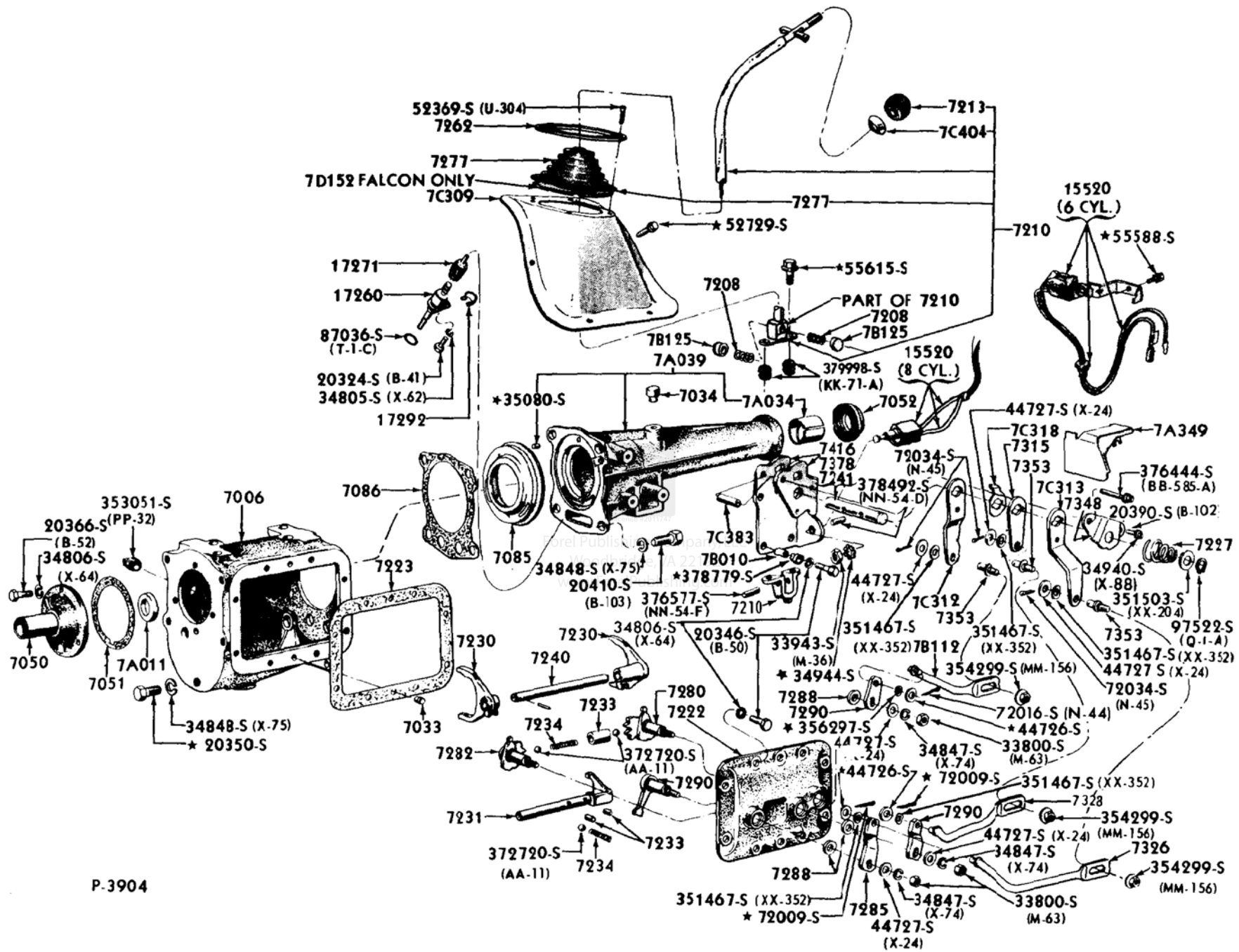

P-3904

**GEAR SHIFT MECHANISM
4 SPEED MANUAL TRANSMISSION - DAGENMAN DESIGN
1965 / 66 MUSTANG**

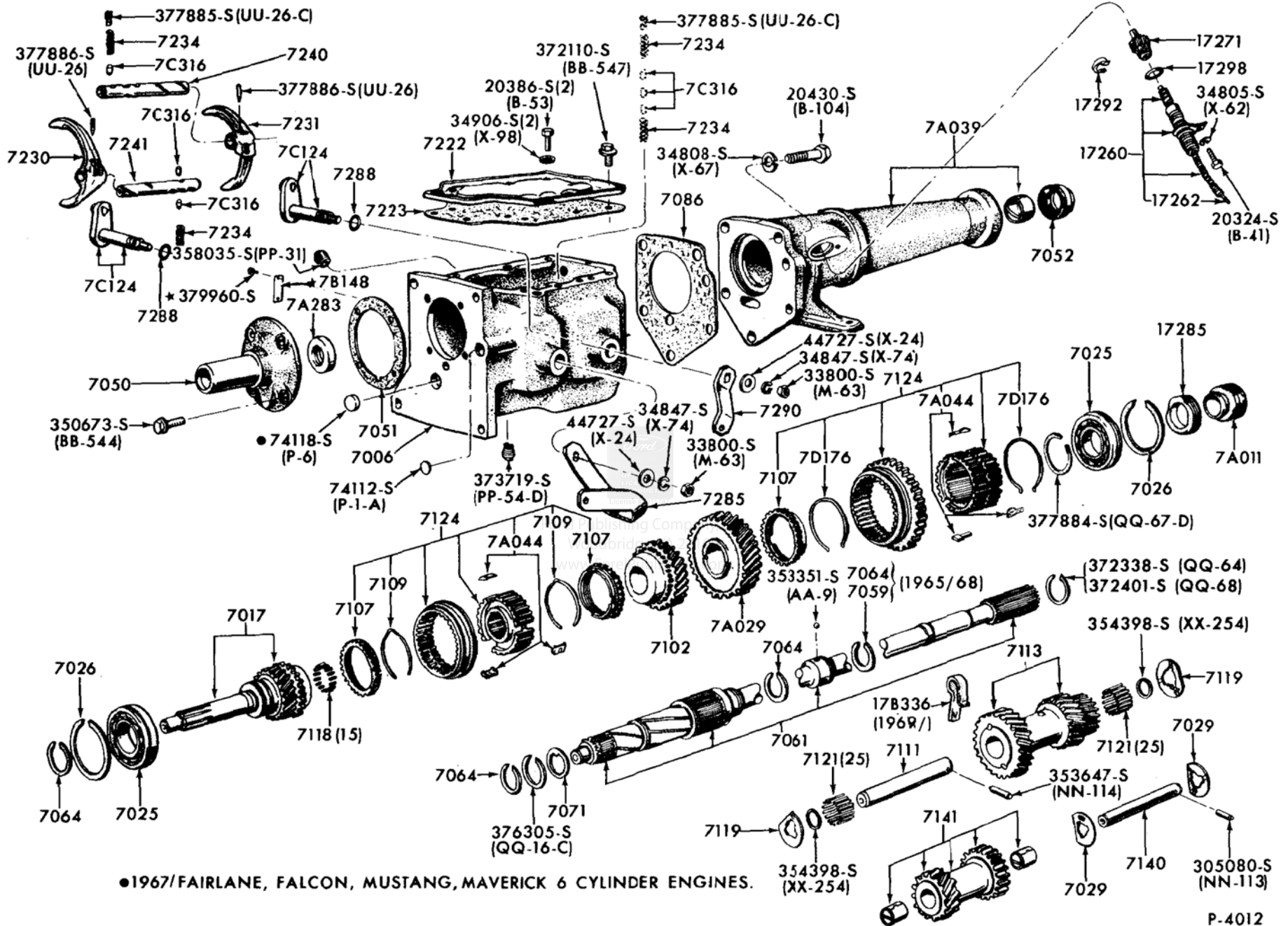

3 SPEED MANUAL TRANSMISSION - 3.03 TYPE - TYPICAL
1965 / 71 FORD, FAIRLANE / TORINO, MUSTANG, 1966 / 71 BRONCO, 1970 / 71 MAVERICK

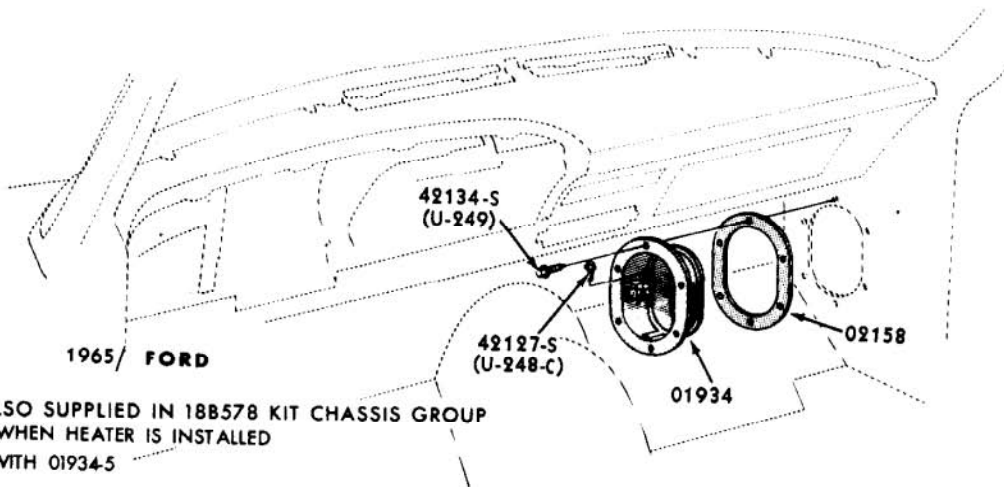
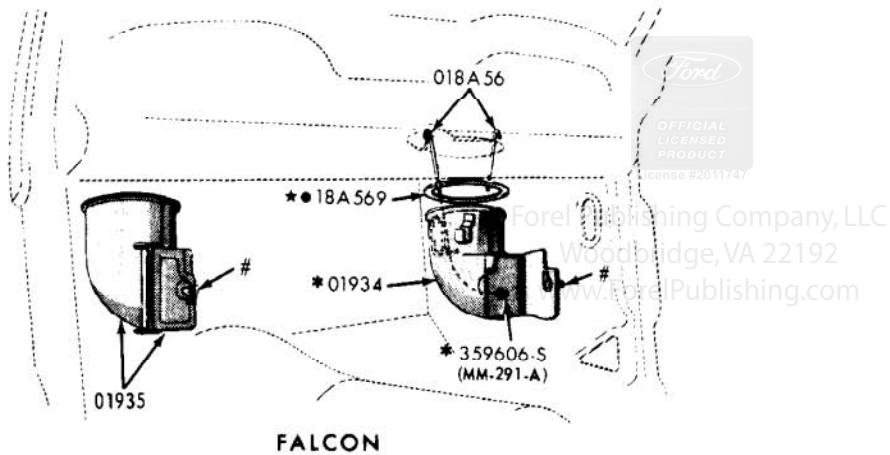
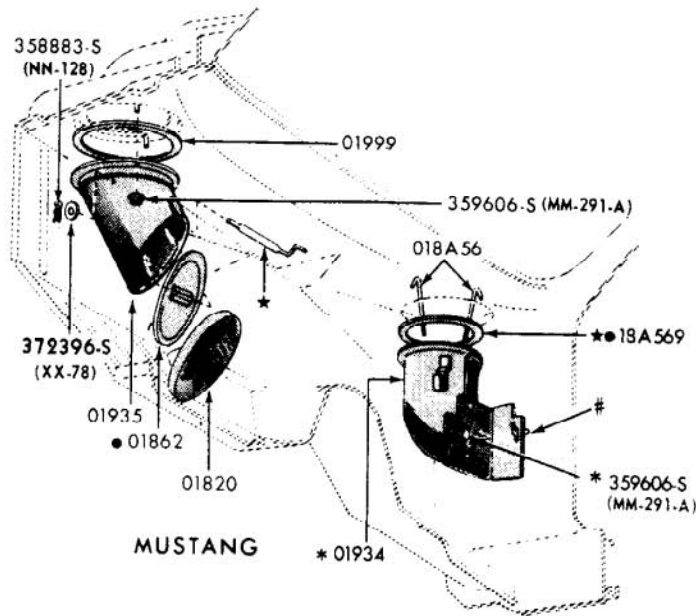
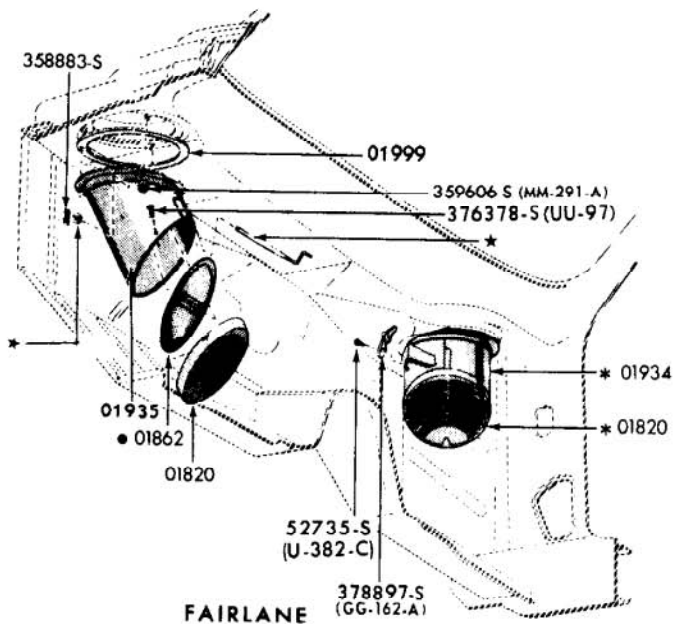

- # HANDLE ALSO SUPPLIED IN 188578 KIT CHASSIS GROUP
- * NOT USED WHEN HEATER IS INSTALLED
- INCLUDED WITH 01934-5

VENTILATING DUCTS
1965 / 68 FORD, FAIRLANE / TORINO, FALCON AND MUSTANG - TYPICAL

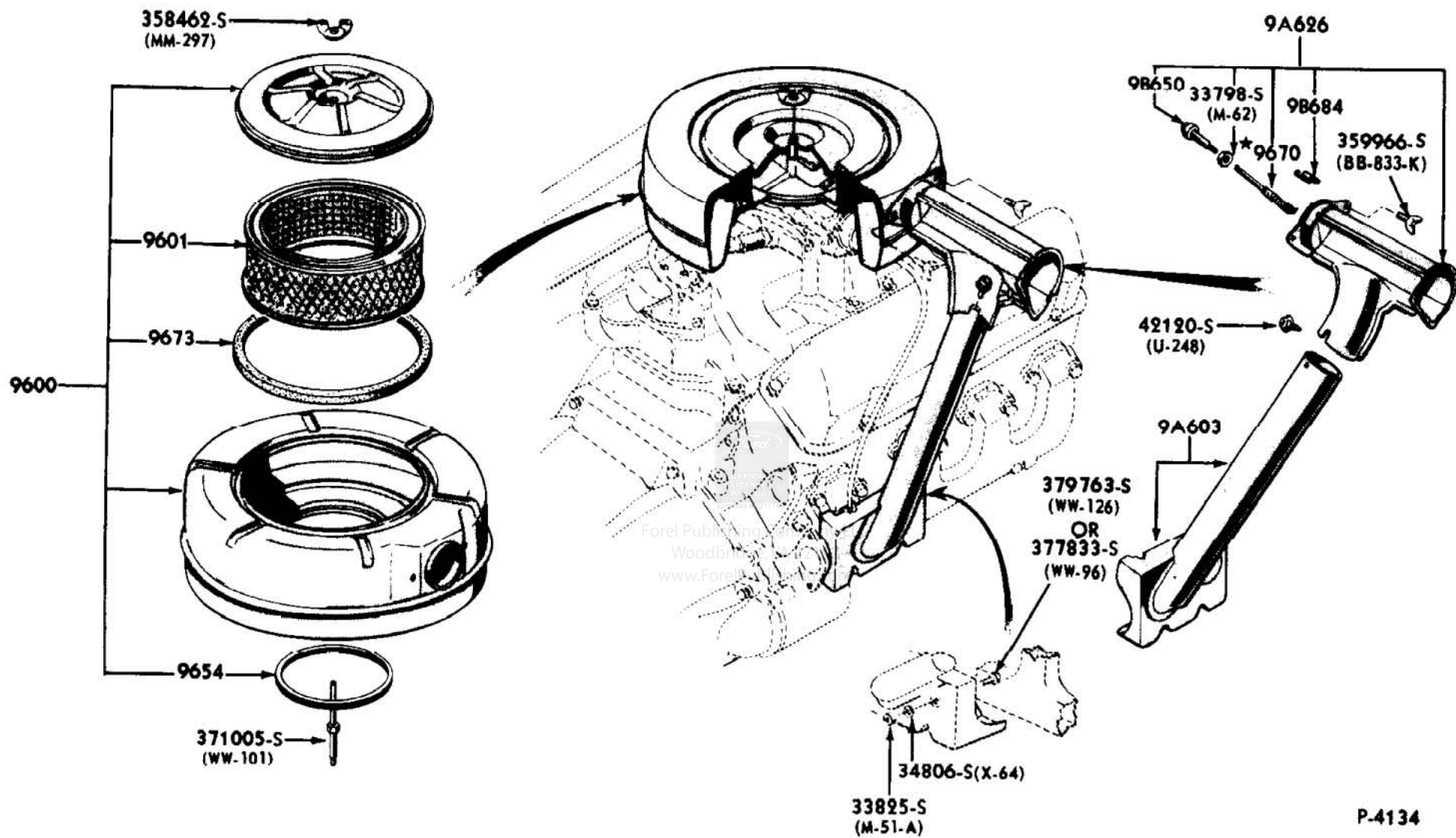

P-4134

AIR CLEANER - 8 CYLINDER
1965 / 67 FORD, FAIRLANE AND FALCON (289 ENGINES)
1965 / 67 MUSTANG (260, 289 ENGINES - EXCEPT F SPECIAL)

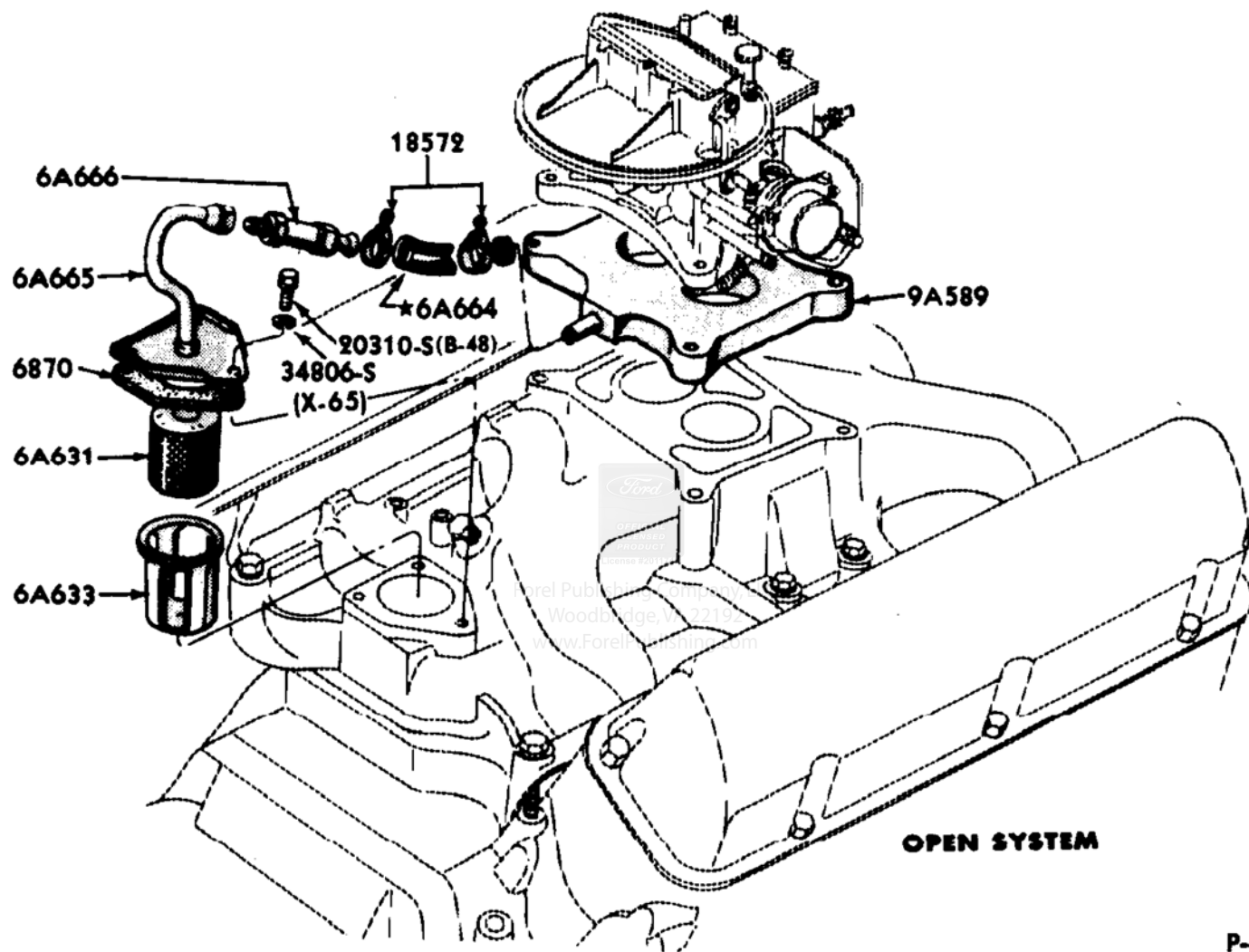

P-4146

ENGINE EMISSION REDUCTION AND RELATED PARTS - INTAKE MANIFOLD TYPE
1965 8 CYLINDER 260 AND 289

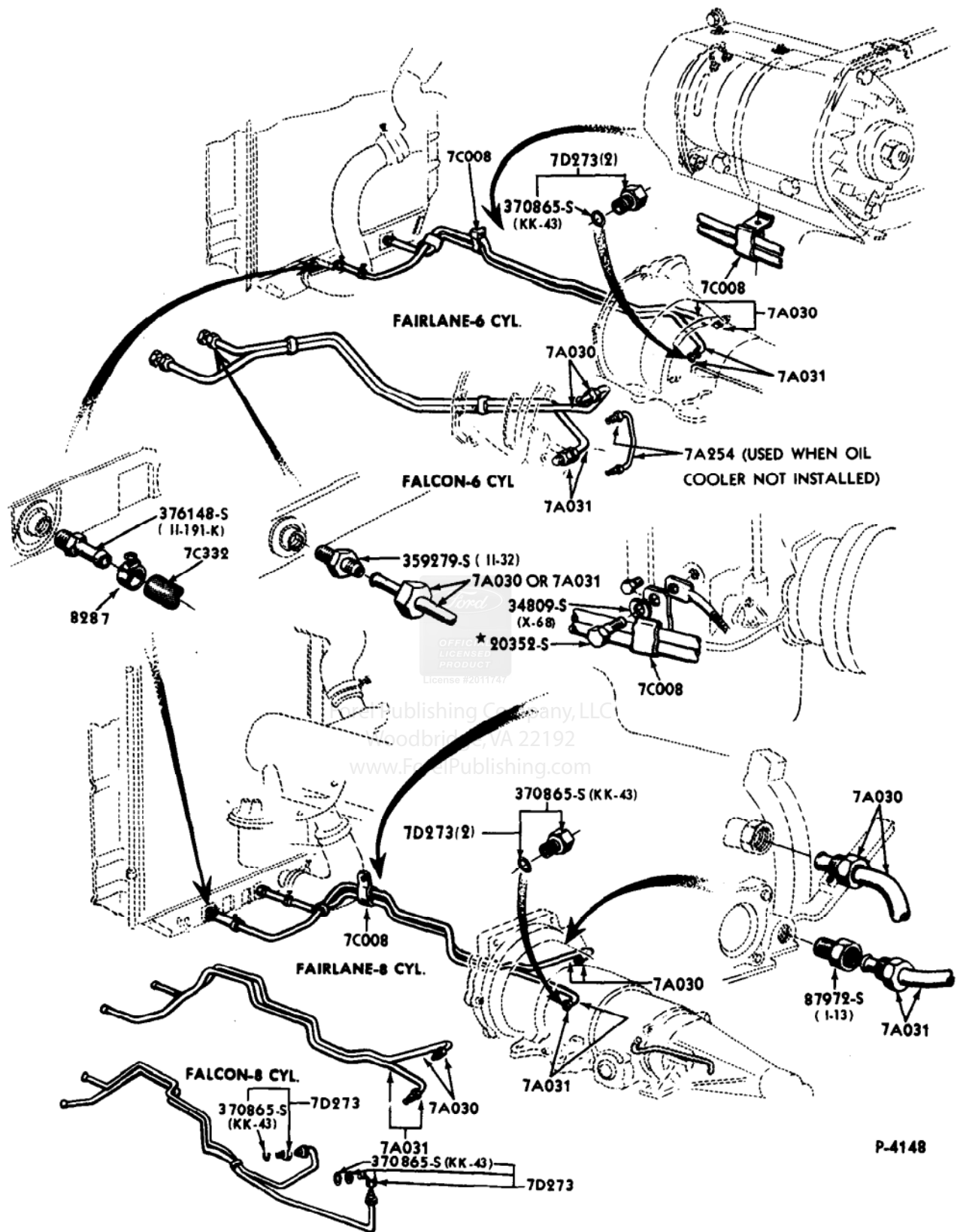

FALCON - 8 CYL., MUSTANG - 6 & 8 CYL.
WITH C-4 DUAL RANGE TRANS.

P-4148

TRANSMISSION OIL COOLING SYSTEM - TYPICAL
1965 FAIRLANE, MUSTANG & FALCON

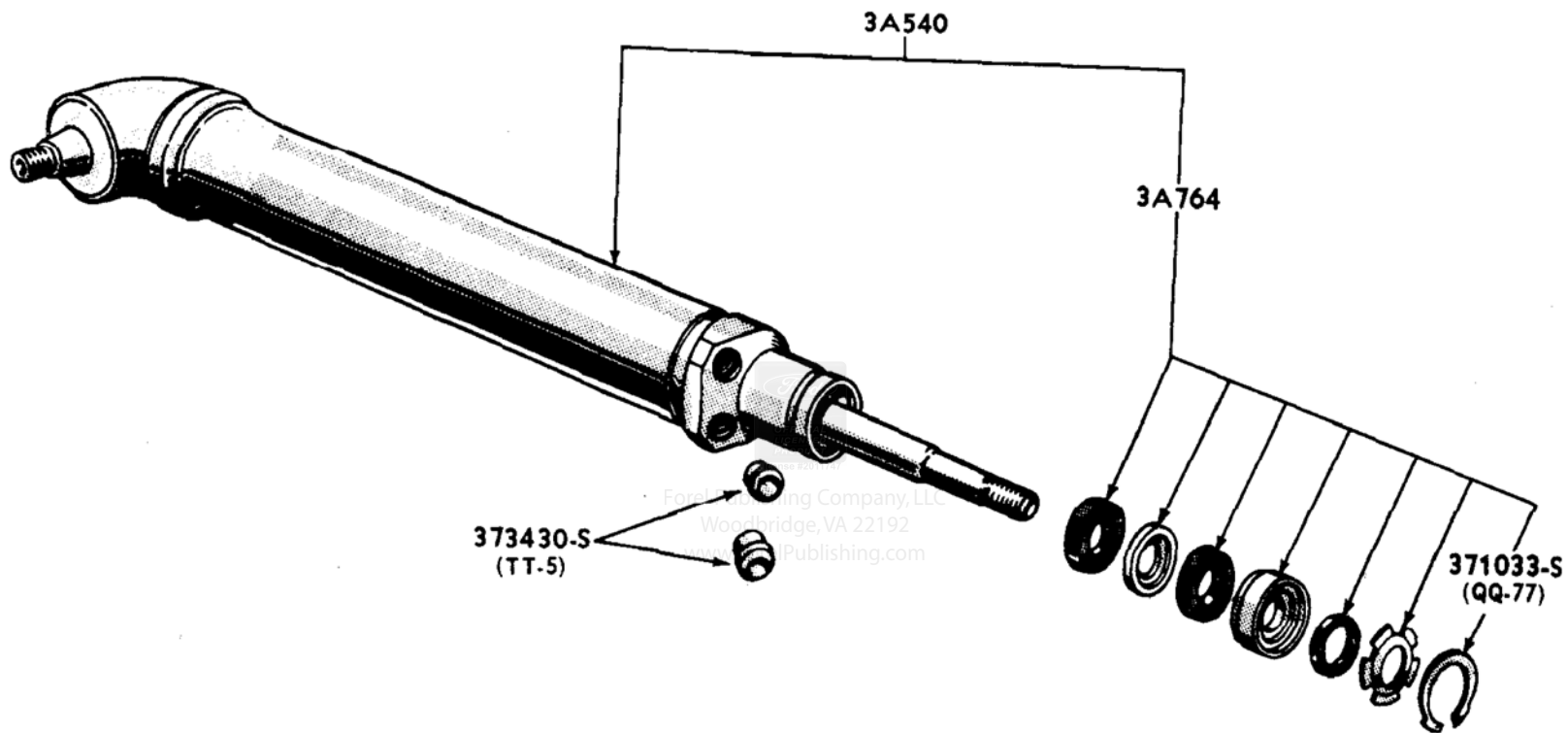

P-4180

POWER STEERING CYLINDER DETAILS - TYPICAL
1965/71 FAIRLANE/TORINO, 1965/70 FALCON & MUSTANG, 1970/72 MAVERICK

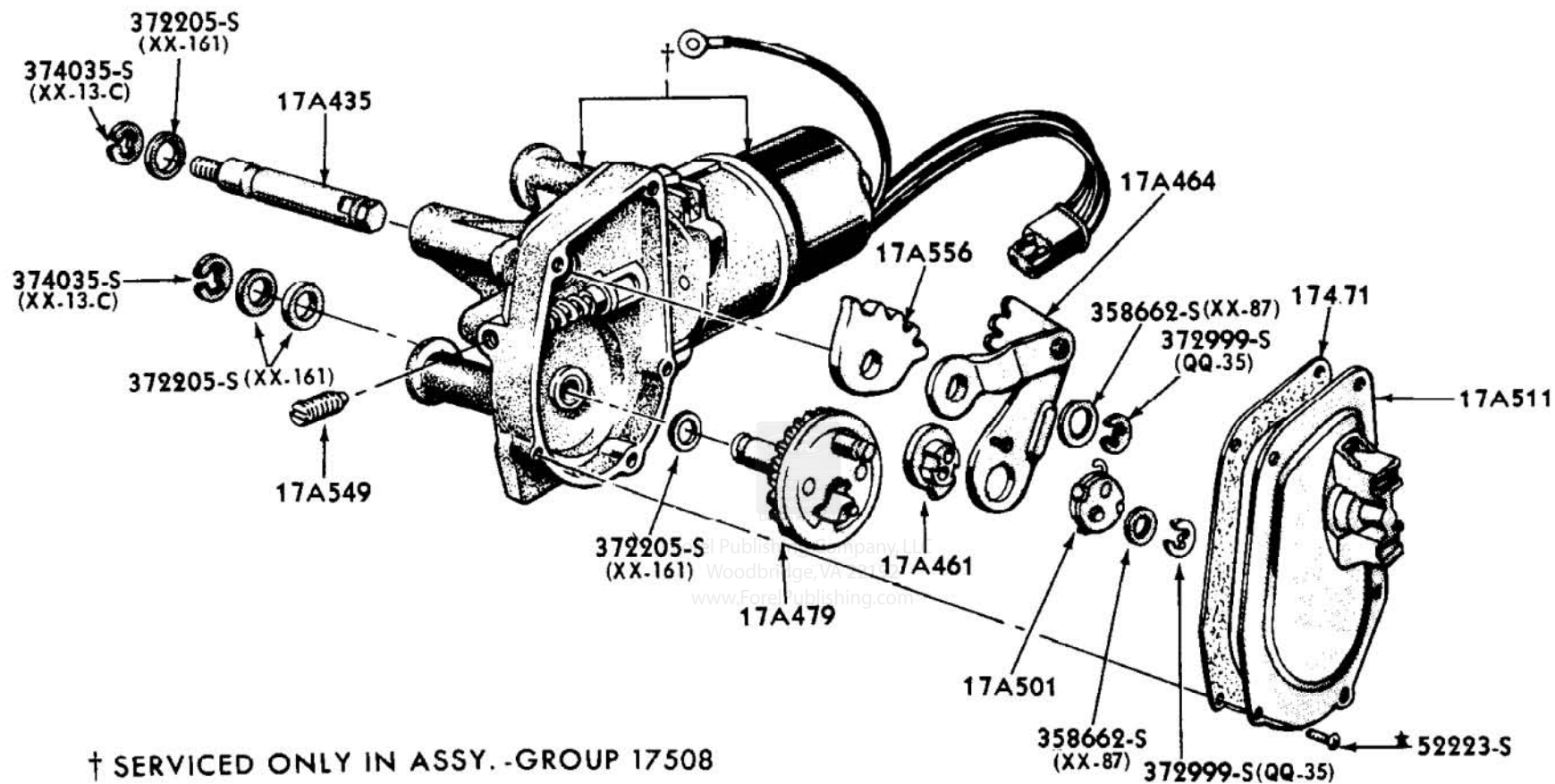

P-4200

WINDSHIELD WIPER MOTOR (2 SPEED FORD ELECTRIC)
 1965 / 68 FORD, 1965/ FAIRLANE AND FALCON, 1965 / 66 MUSTANG
 1970 THUNDERBIRD

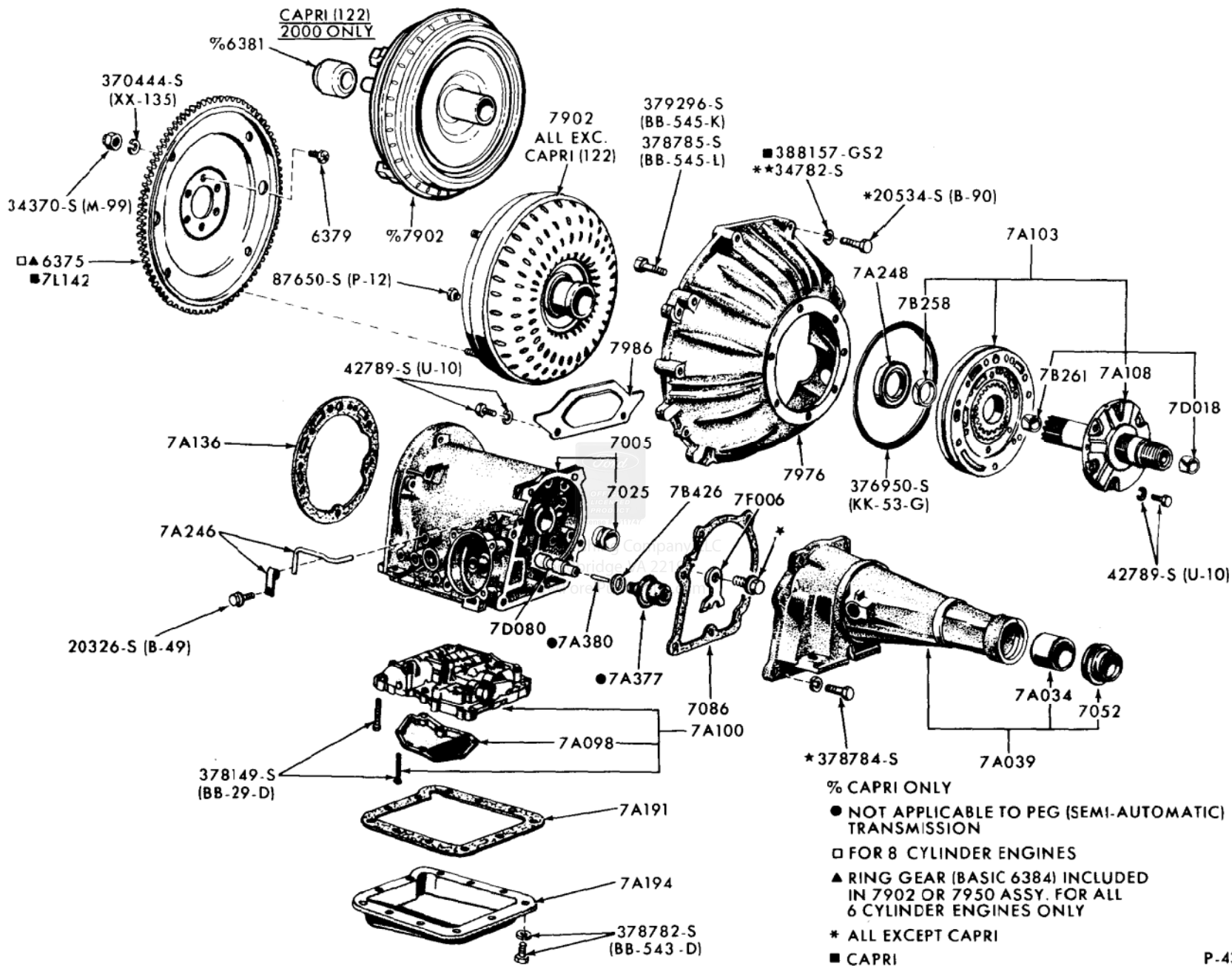

P-4326

CASE CONVERTER ASSY., EXTENSION, PUMP & RELATED PARTS - TYPICAL
1965 / 72 FORD, FAIRLANE / TORINO, MUSTANG & FALCON, 1970 / 72 MAVERICK, 1971 / 72 PINTO

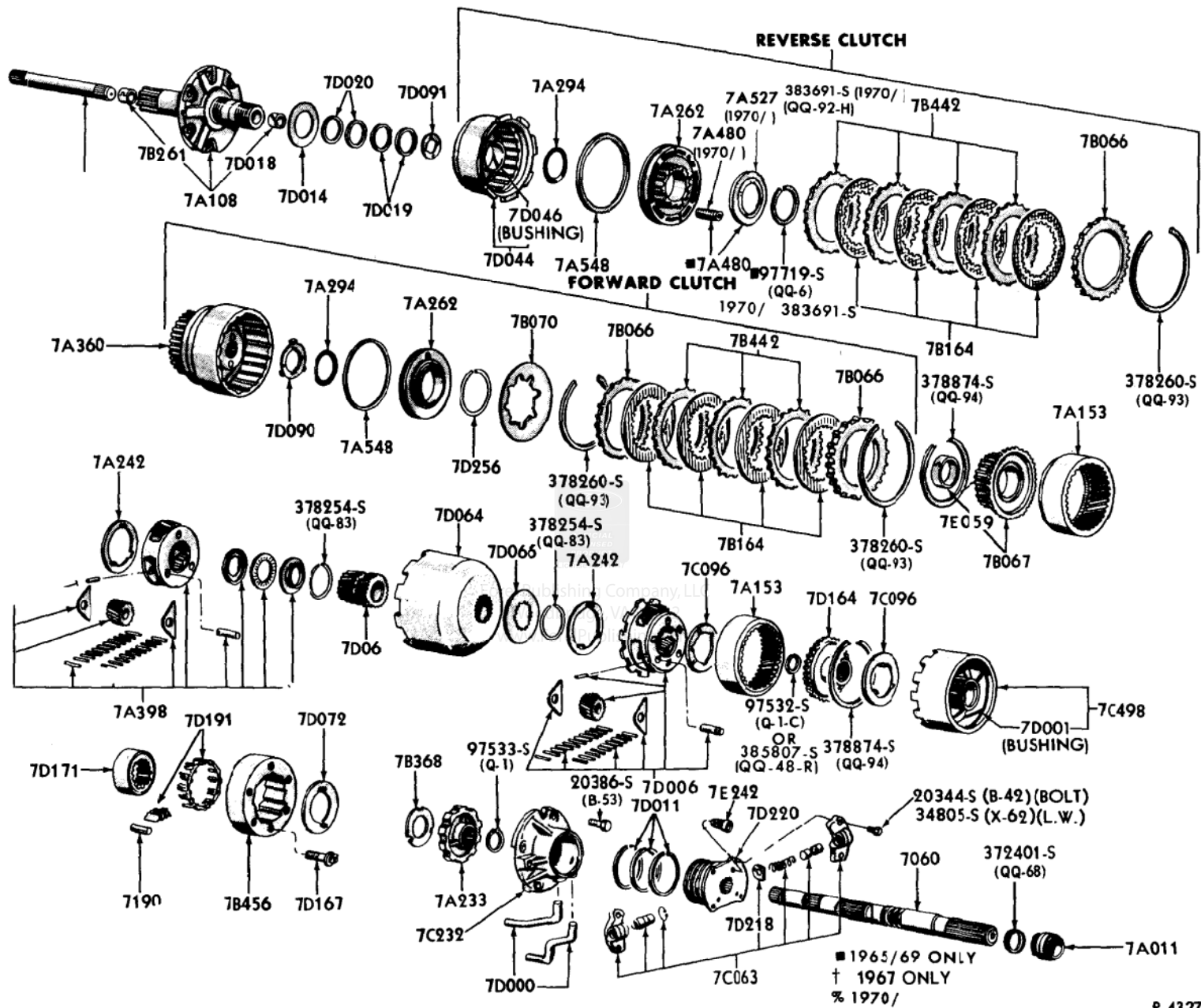

**CLUTCHES, GEARS, SHAFTS, REAR SUPPORT & RELATED PARTS - TYPICAL
 1965 / 72 FORD, FAIRLANE / TORINO, MUSTANG & FALCON, 1970 / 72 MAVERICK, 1971 / 72 PINTO**

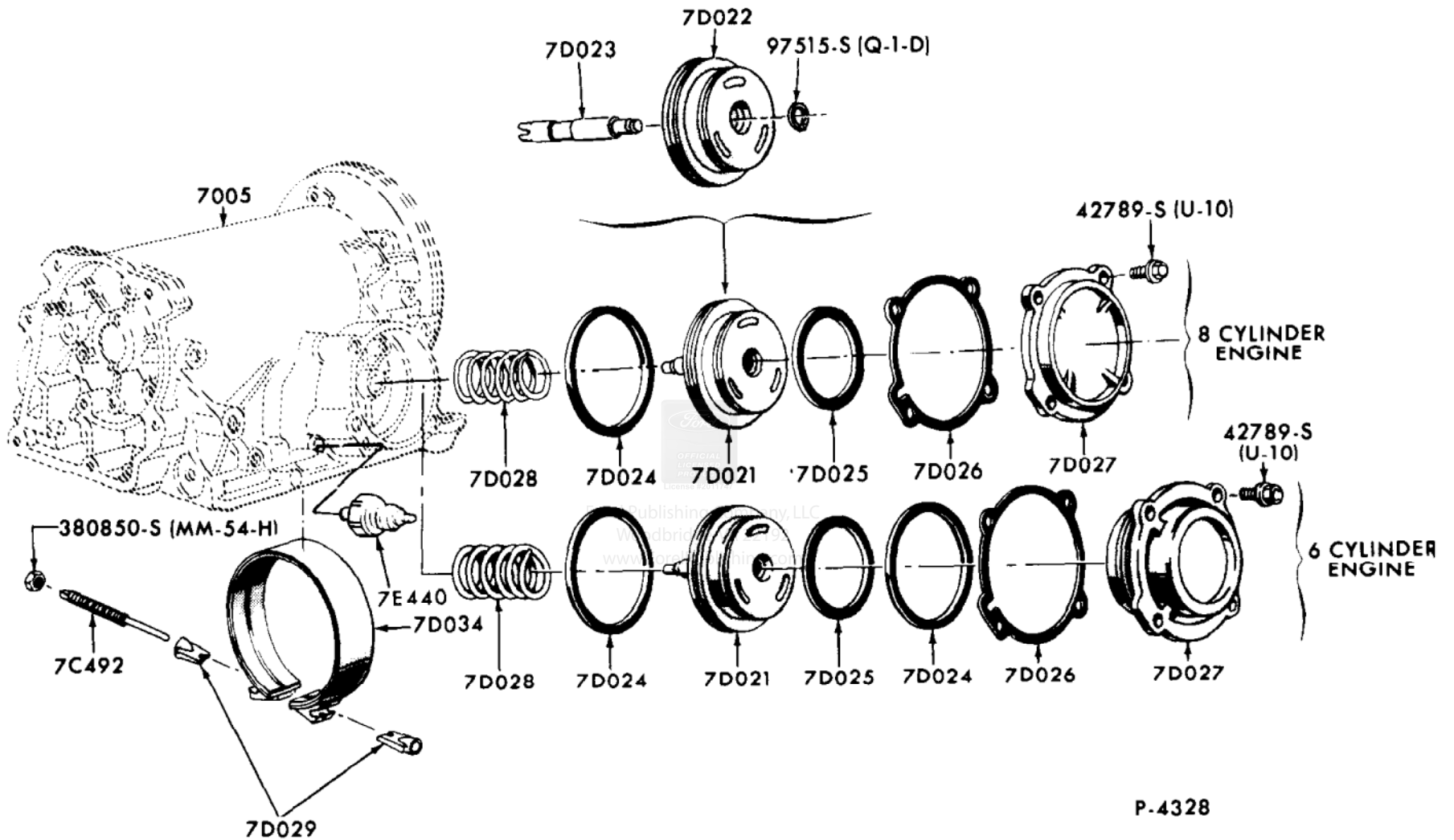

FRONT SERVO & BAND - TYPICAL
1965 / 72 FORD, FAIRLANE / TORINO, MUSTANG & FALCON, 1970 / 72 MAVERICK, 1971 / 72 PINTO

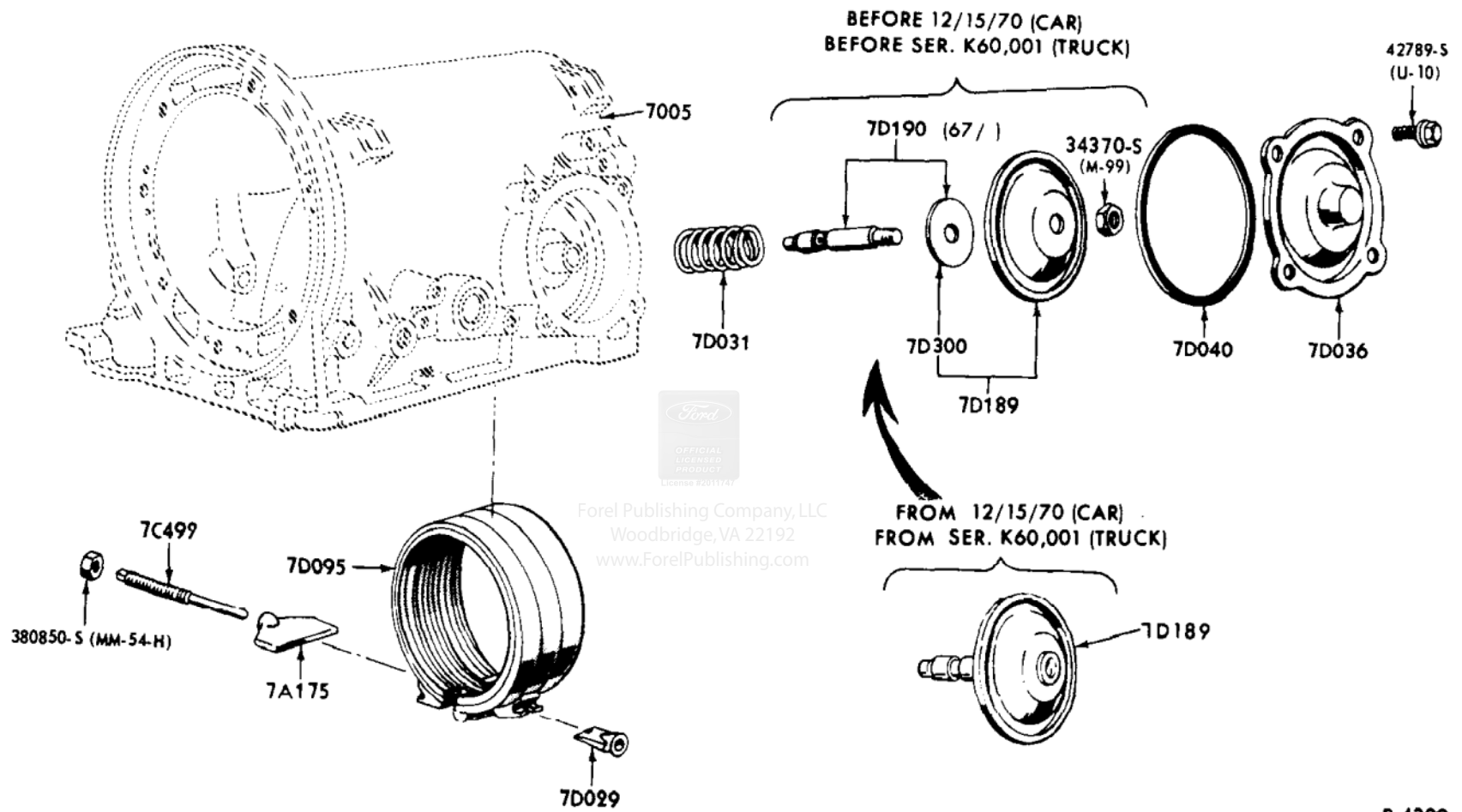

P-4390

REAR SERVO & BAND - TYPICAL
1965 / 72 FORD, FAIRLANE / TORINO, MUSTANG & FALCON, 1970 / 72 MAVERICK, 1971 / 72 PINTO

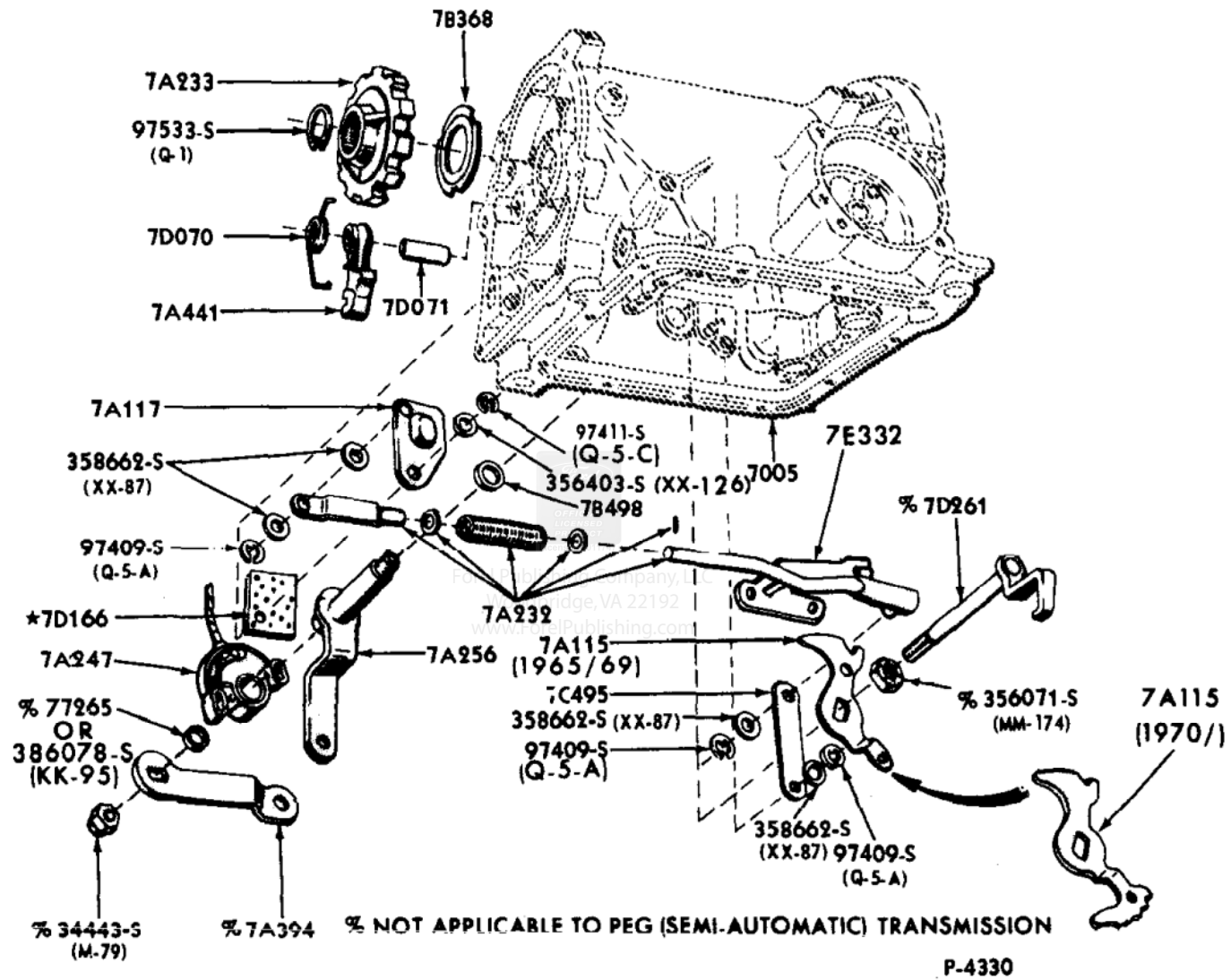

PARKING PAWL, THROTTLE & MANUAL CONTROL LINKAGE - TYPICAL
 1965 / 72 FORD, FAIRLANE / TORINO, MUSTANG & FALCON, 1970 / 72 MAVERICK, 1971 / 72 PINTO

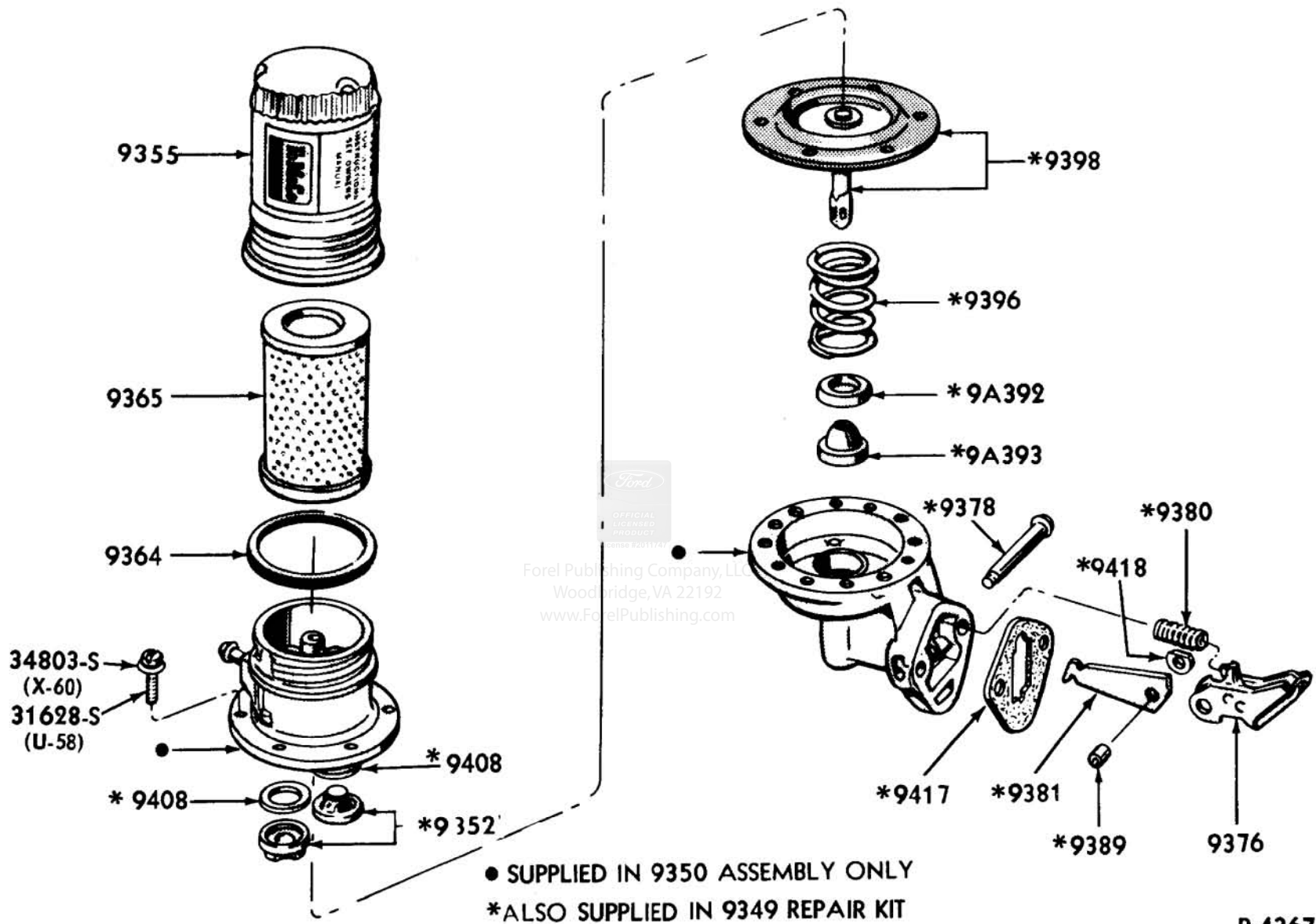

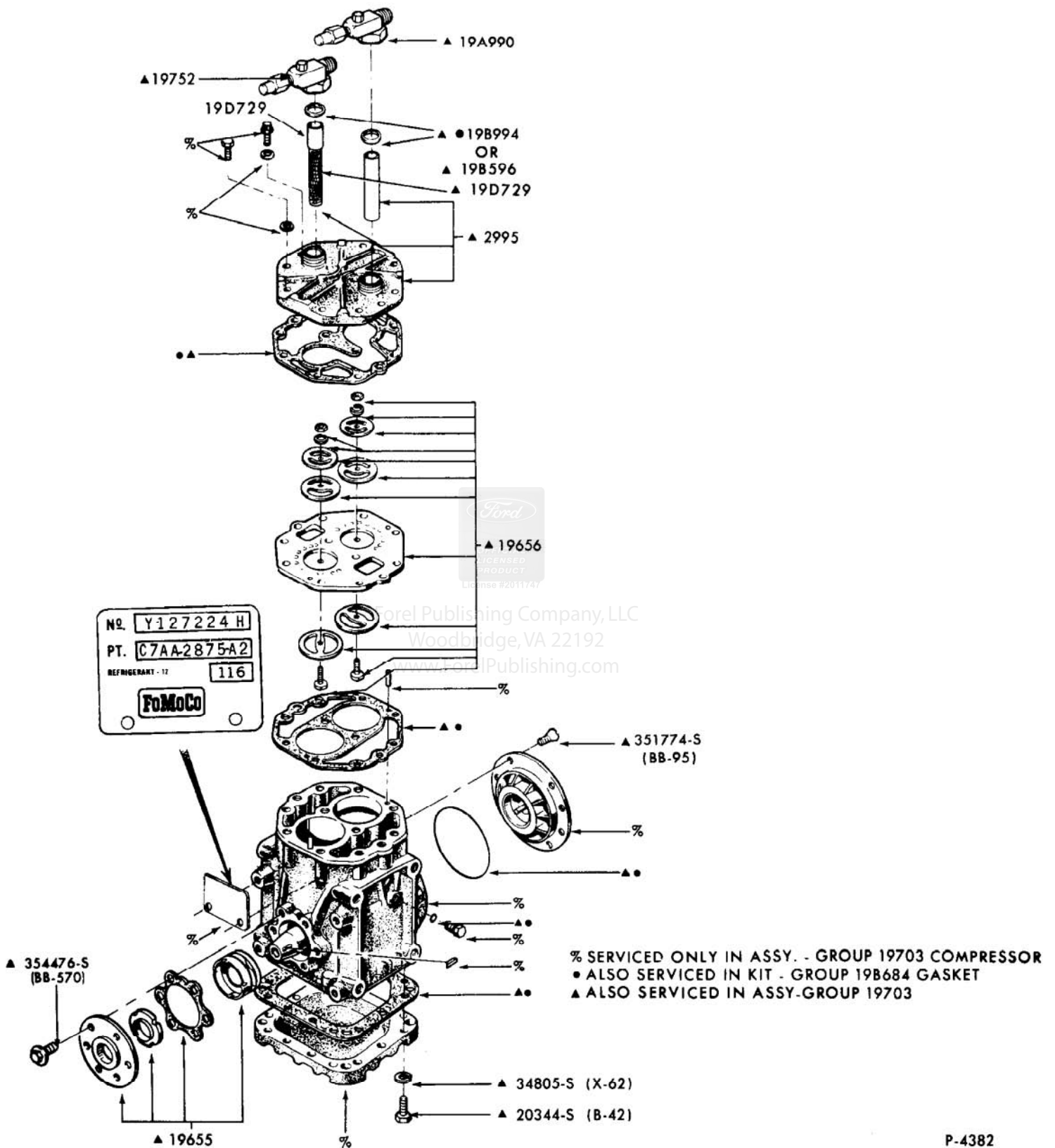

 OFFICIAL LICENSED PRODUCT
 Forel Publishing Company, LLC
 Woodbridge, VA 22192
 www.ForelPublishing.com

FUEL PUMP AND FILTER ASSY.
 1965 (6 CYLINDER 170, 200, 240 ENGINES)

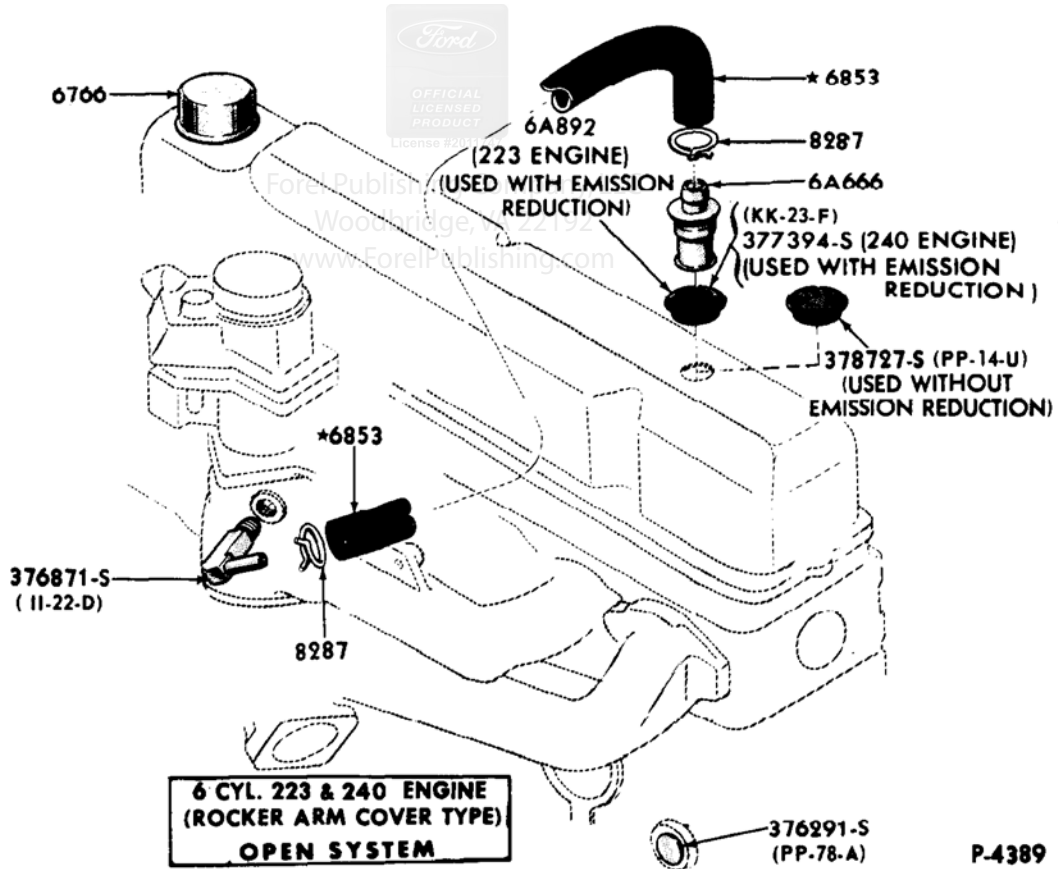
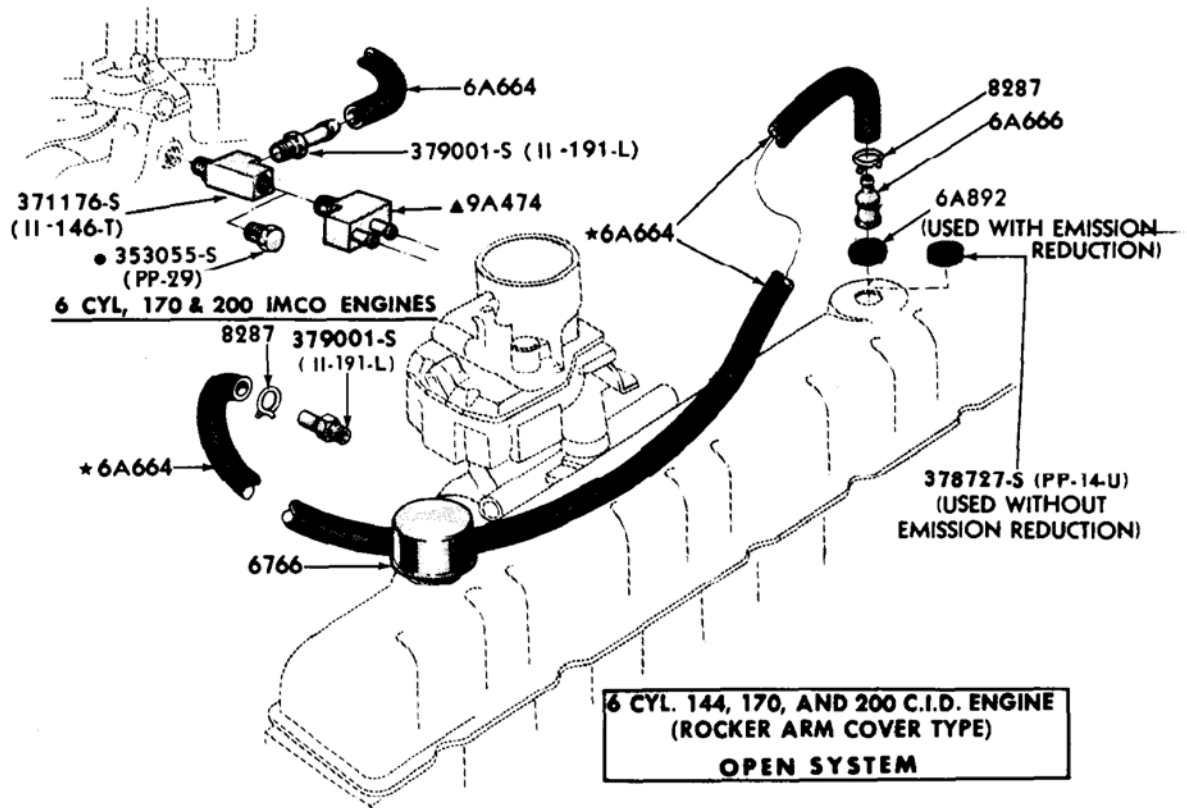

P-4382

COMPRESSOR - AIR CONDITIONER (YORK DESIGN) (ALUMINUM)
1965 / 72 - ALL



● WITHOUT VACUUM ACCESSORIES
▲ WITH VACUUM ACCESSORIES

P-4389

ENGINE EMISSION REDUCTION AND RELATED PARTS - ROCKER ARM COVER TYPE
1965 / 70 6 CYLINDER 170, 200 AND 240

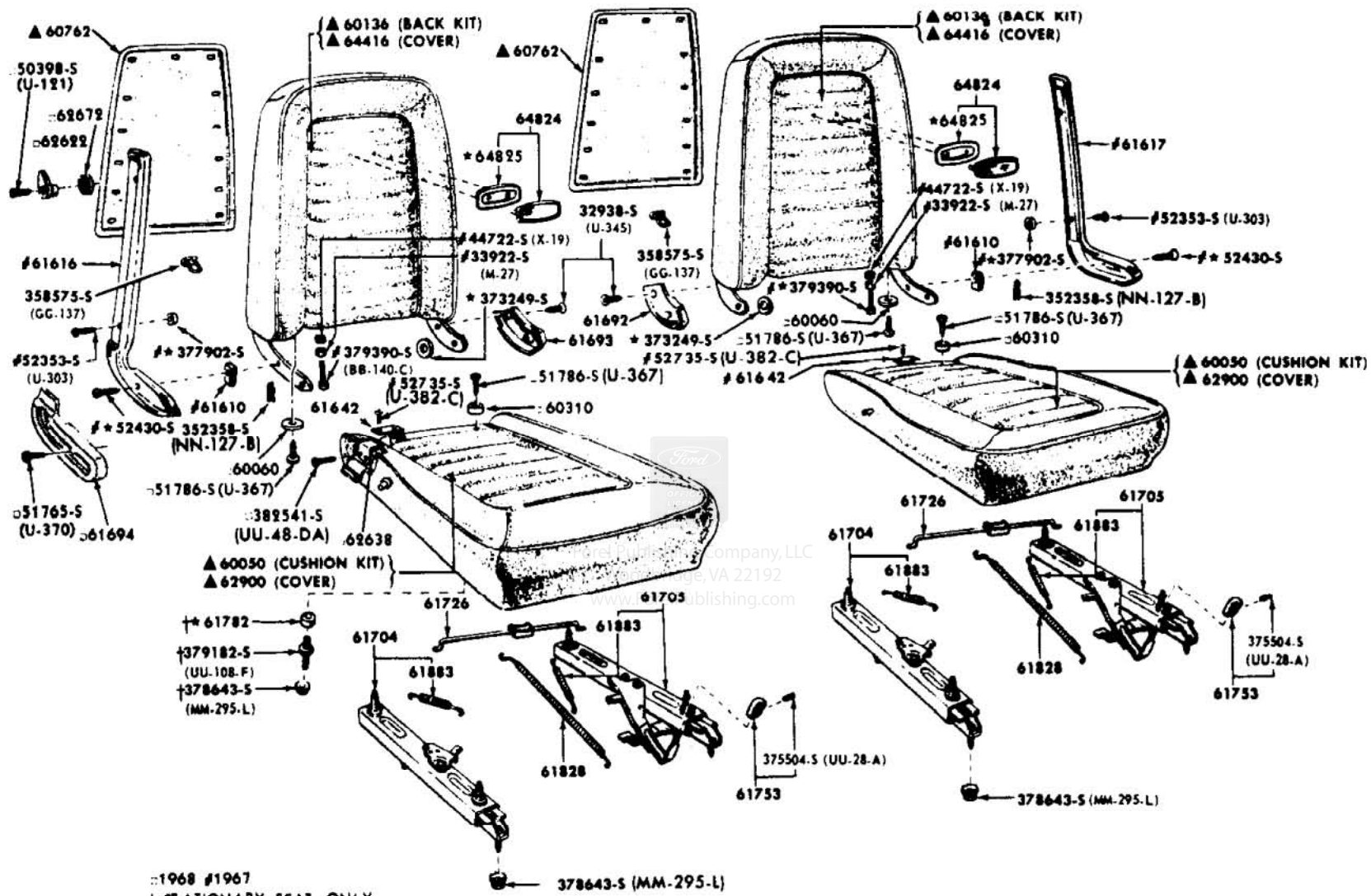

○ 1968 #1967
 † STATIONARY SEAT ONLY
 ▲ REFER TO GROUP IN SOFT TRIM SECTION

FRONT SEAT MECHANISM AND RELATED PARTS - BUCKET
1965 / 66 MUSTANG, 1967 MUSTANG - BODY TYPE 63A, 65A, 76A AND 1968 / 69 MUSTANG

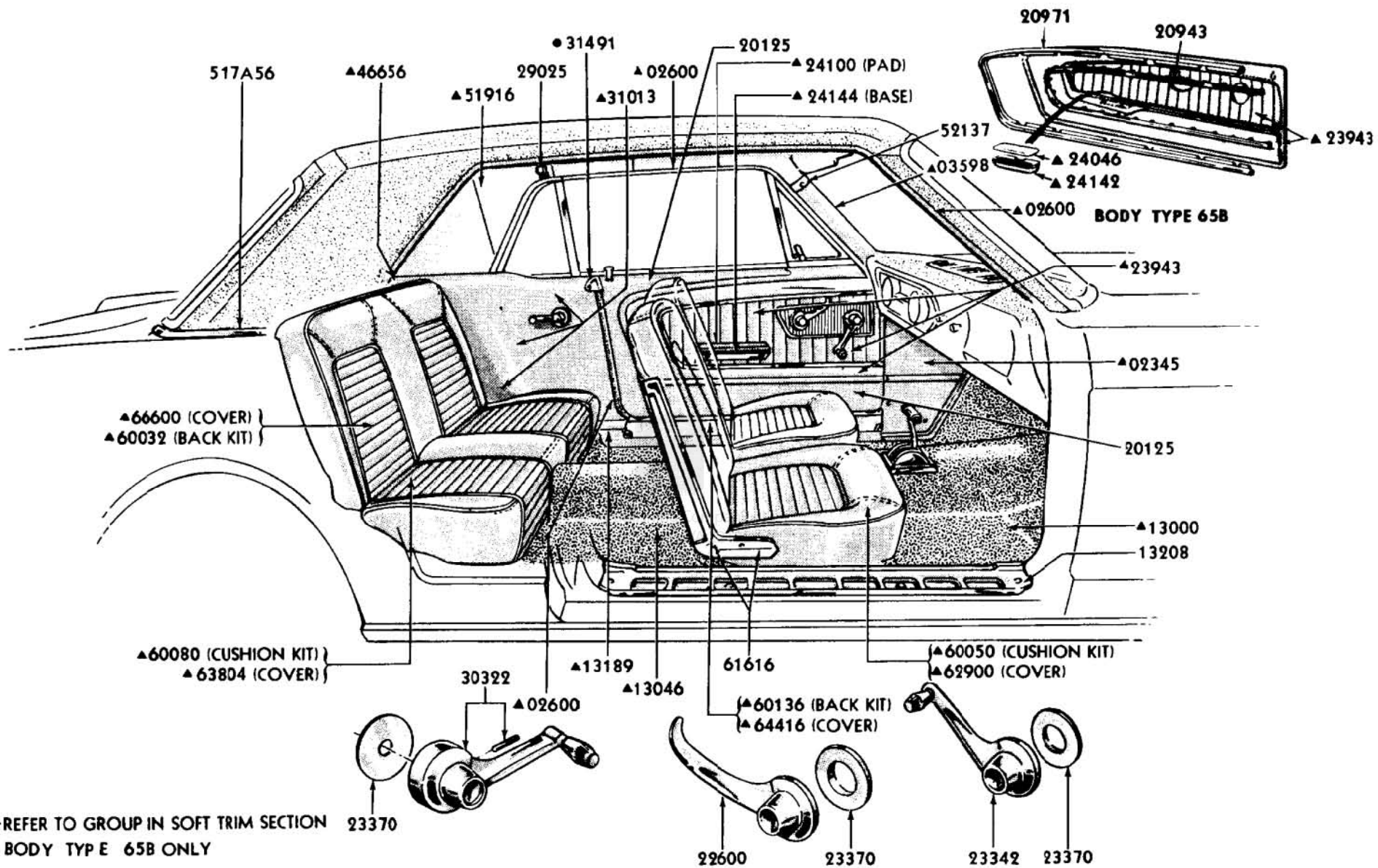

▲REFER TO GROUP IN SOFT TRIM SECTION

●BODY TYPE E 65B ONLY

ALSO SUPPLIED IN ASSEMBLY - GROUP 23942.3

P-4456

INTERIOR TRIM AND RELATED PARTS - TYPICAL
 1965 / 66 - MUSTANG - BODY TYPE 65

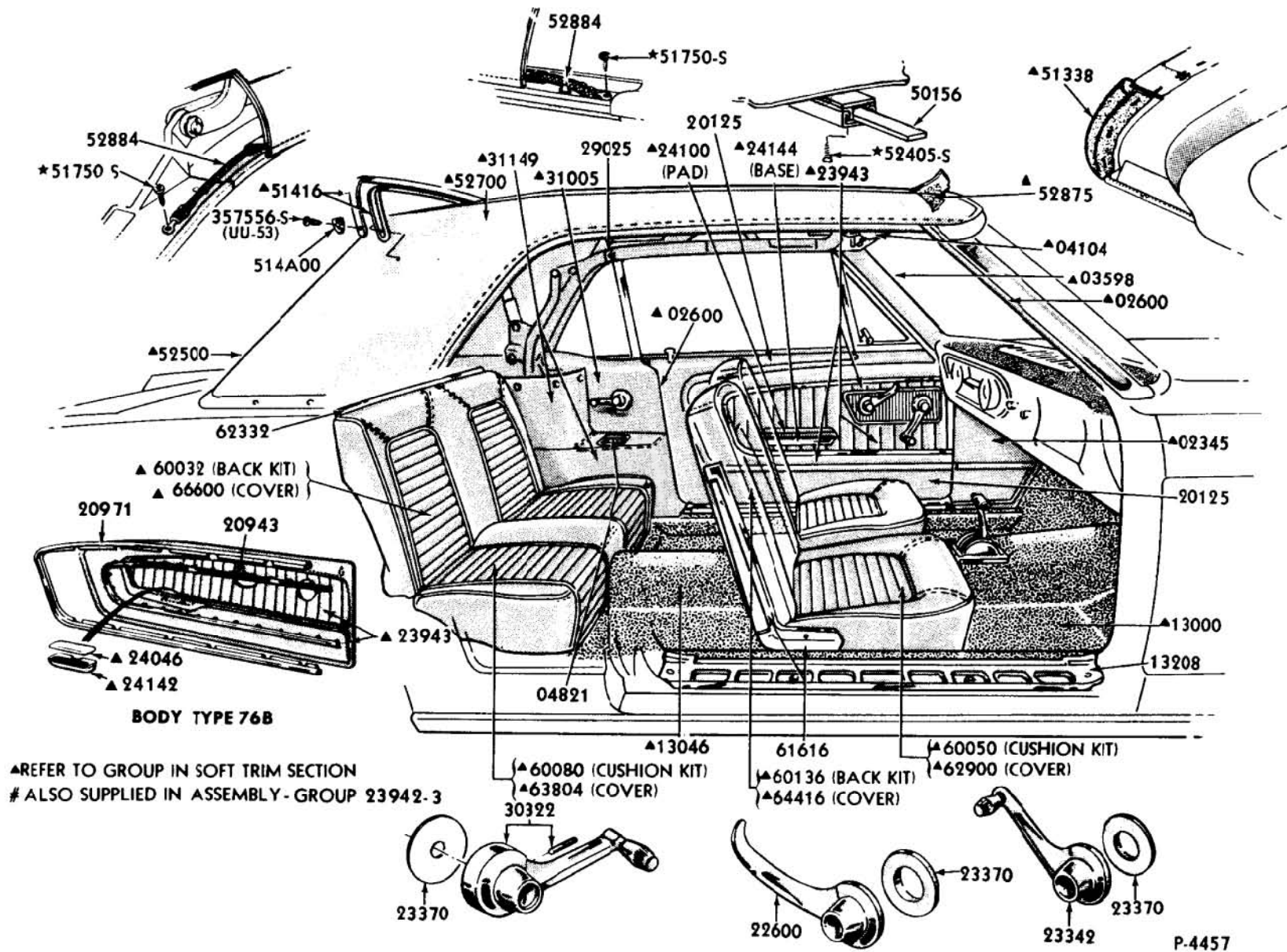

**INTERIOR TRIM AND RELATED PARTS - TYPICAL
 1965 / 66 - MUSTANG - BODY TYPE 76**

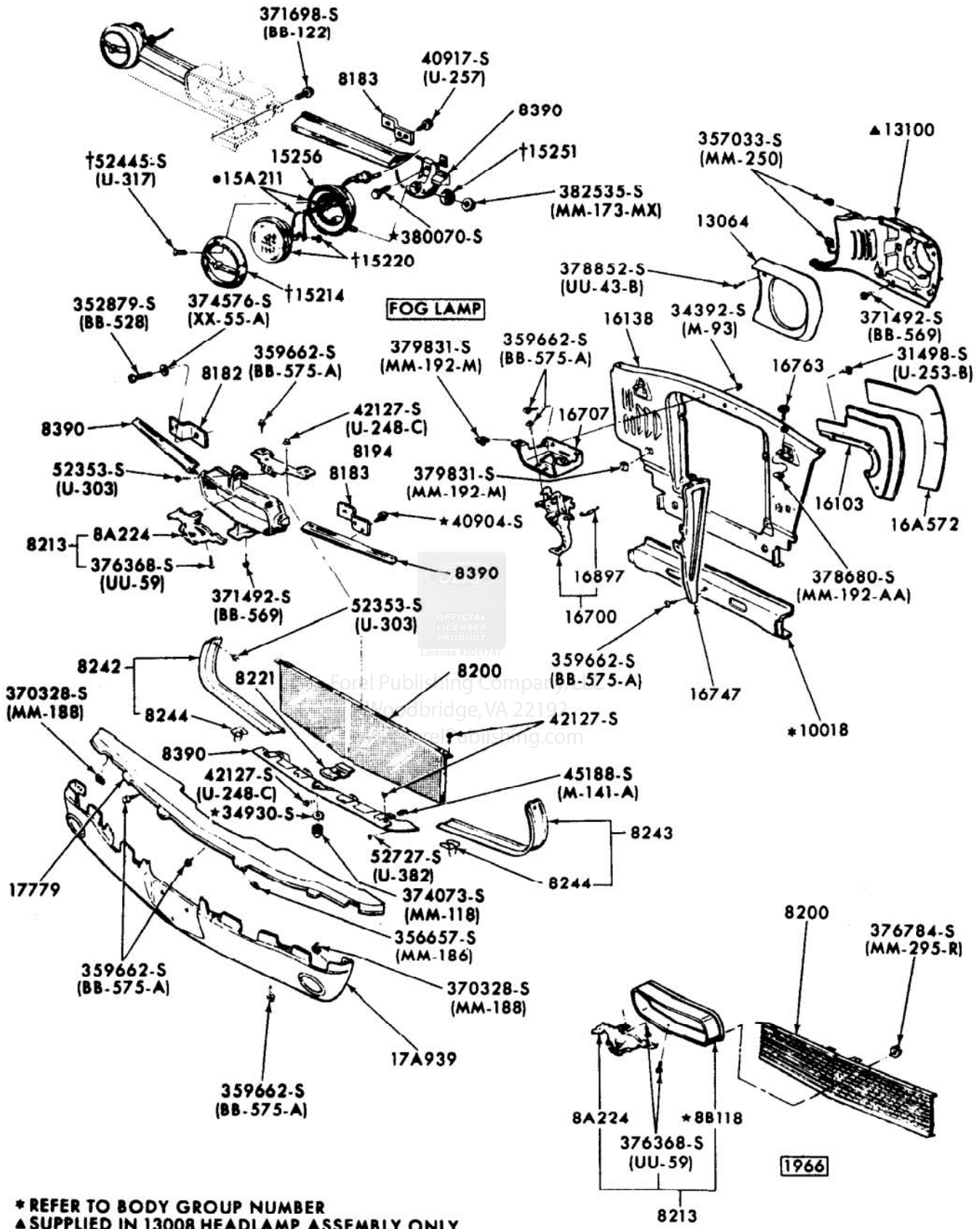

* REFER TO BODY GROUP NUMBER
 ▲ SUPPLIED IN 13008 HEADLAMP ASSEMBLY ONLY
 • SUPPLIED ONLY IN 15200 LAMP ASSEMBLY
 † ALSO SUPPLIED IN 15200 LAMP ASSEMBLY

**RADIATOR GRILLE AND RELATED PARTS
 1965 / 66 MUSTANG**

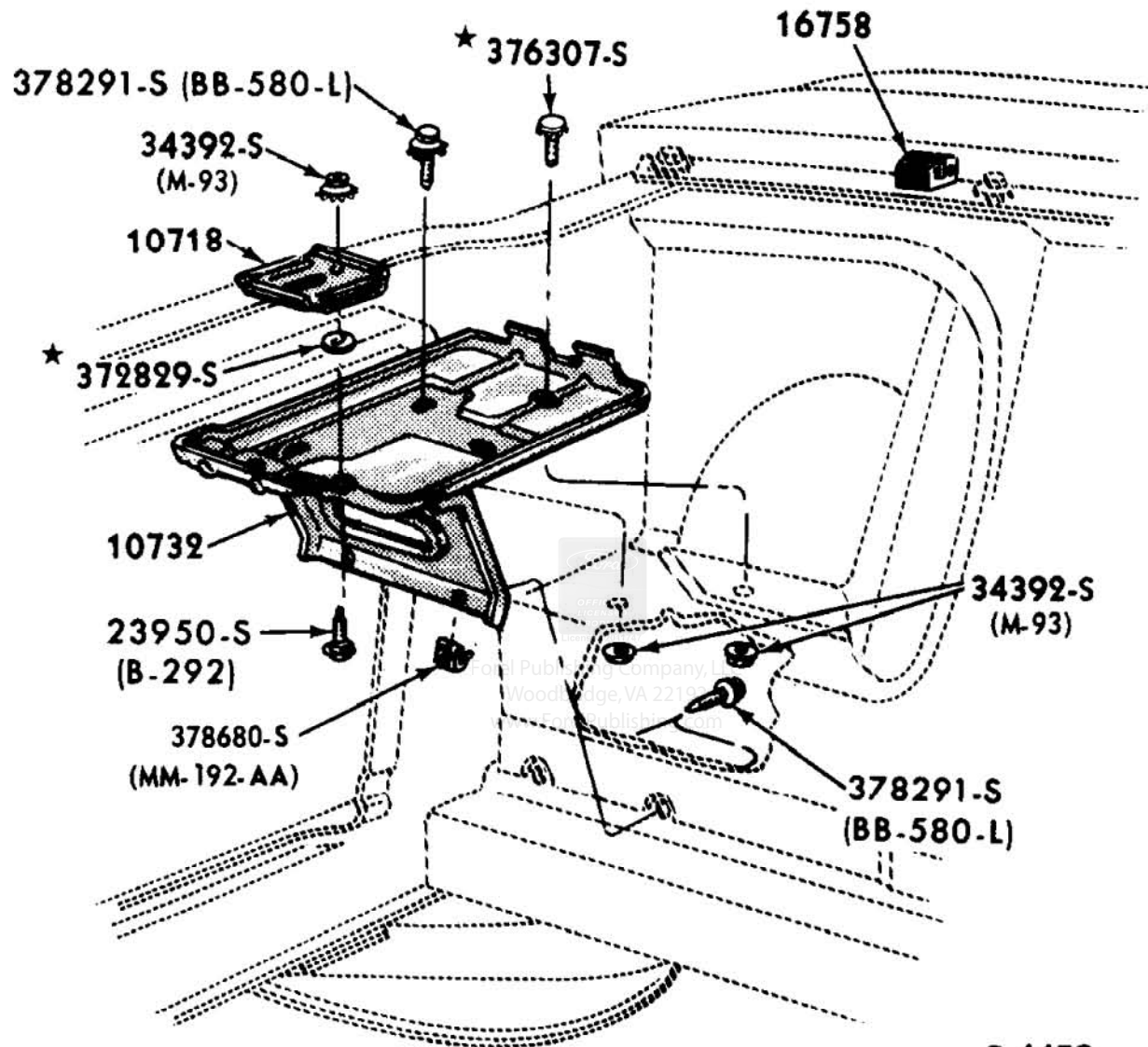

P-4459

BATTERY CARRIER AND RELATED PARTS
 1965 / 68 MUSTANG

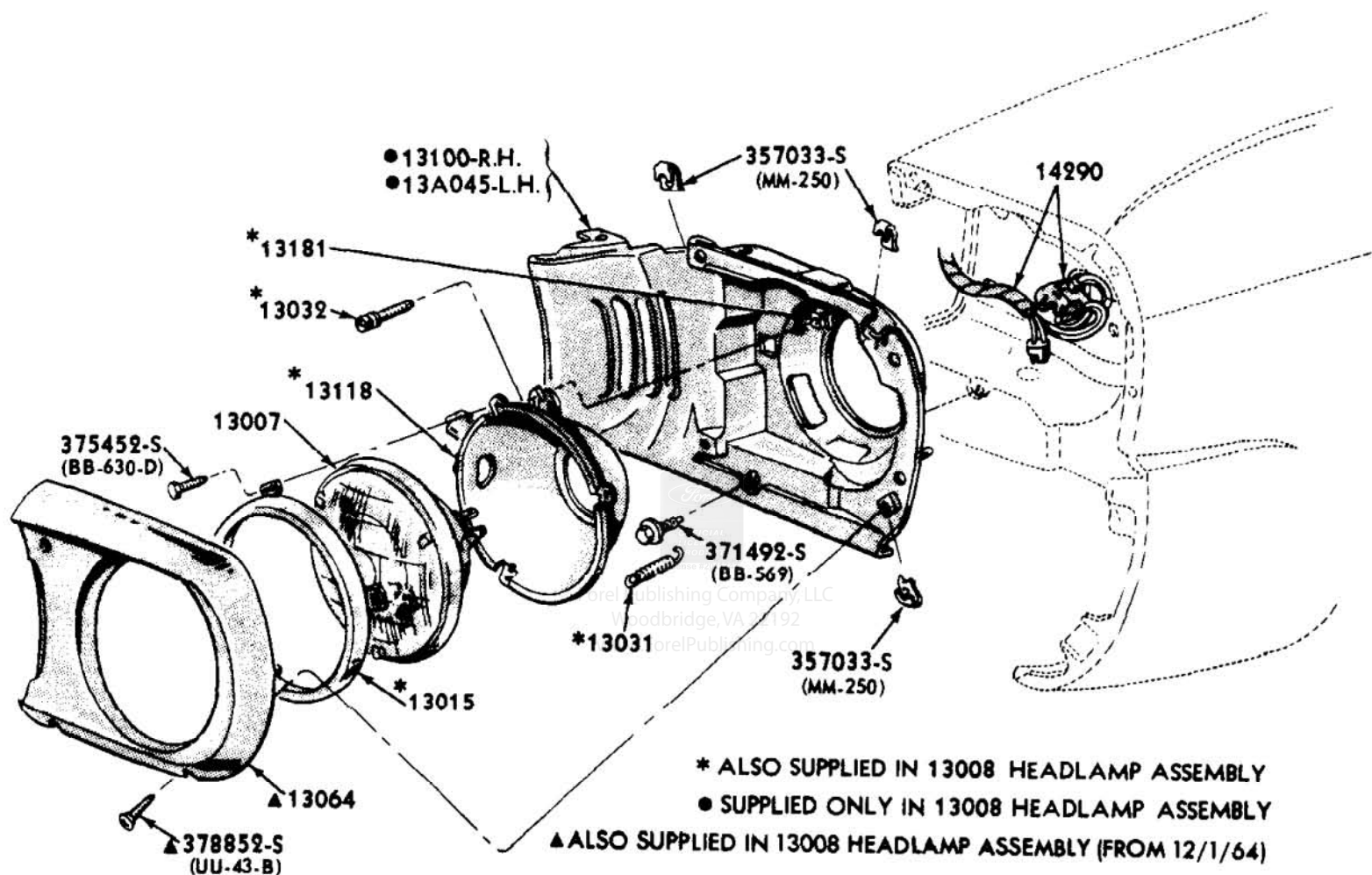

P-4460

HEADLAMP PARTS
1965 / 66 MUSTANG

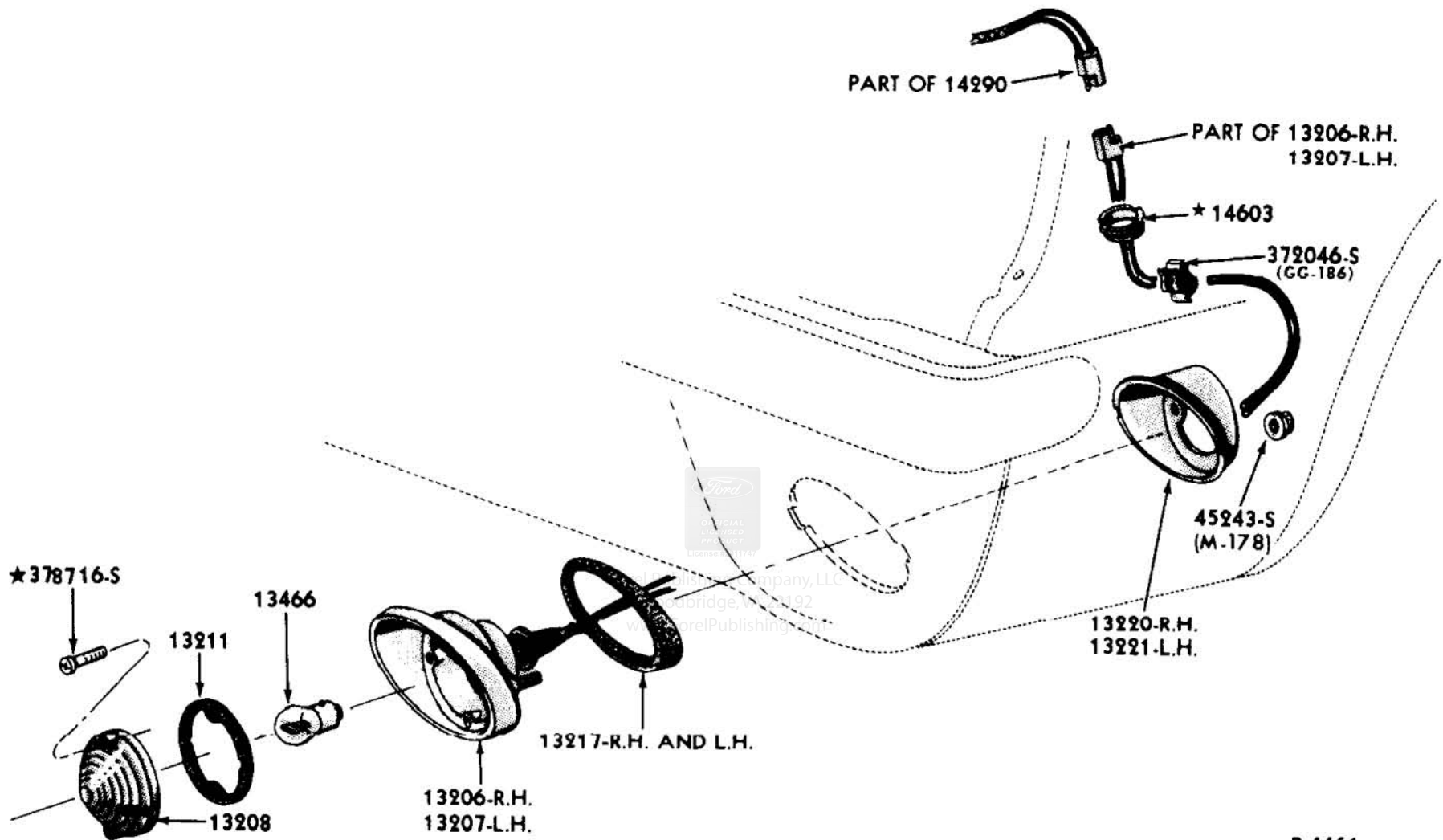

P-4461

PARKING LAMP
1965 / 66 MUSTANG

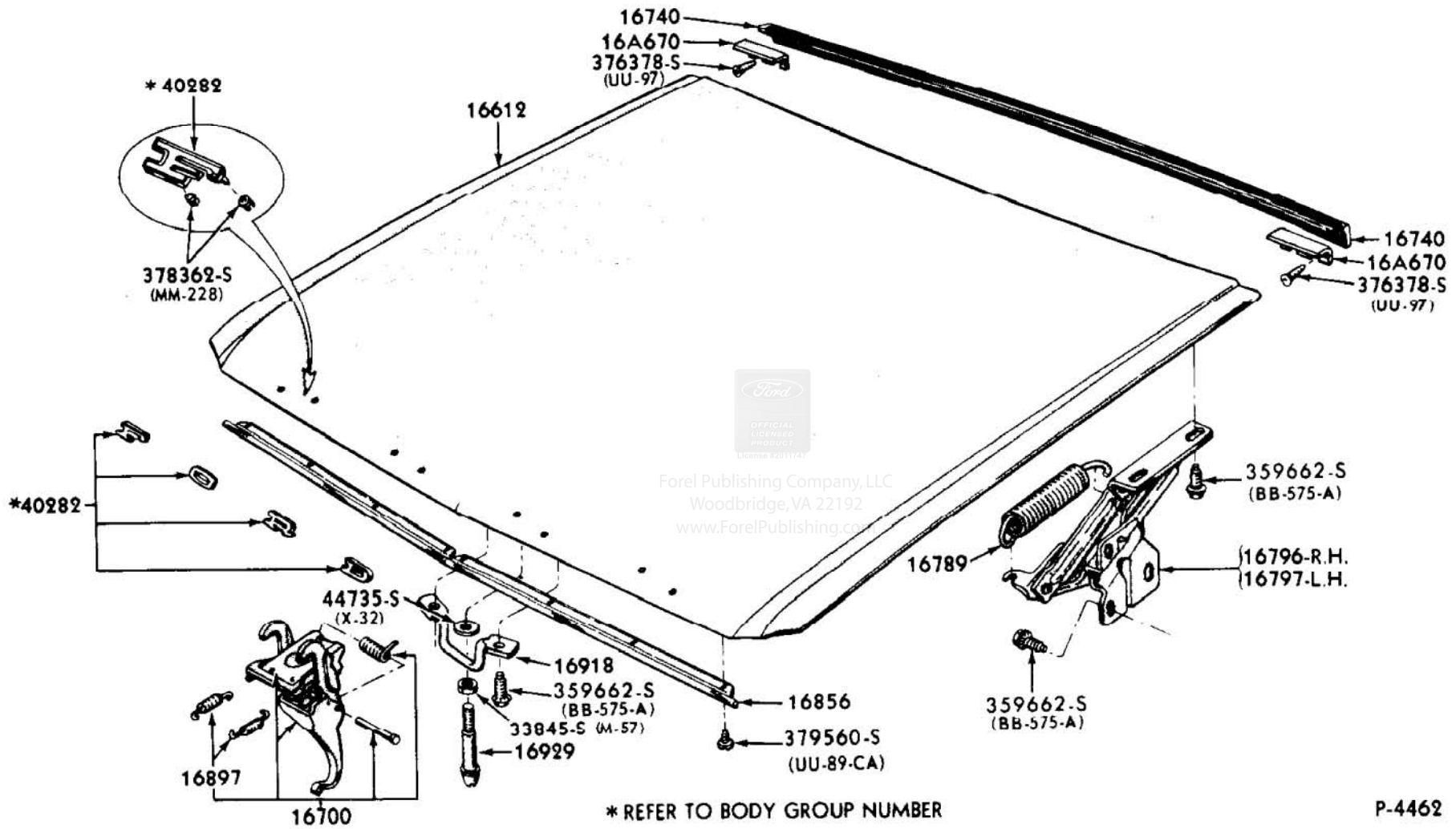

P-4462

HOOD AND RELATED PARTS
1965 / 66 MUSTANG

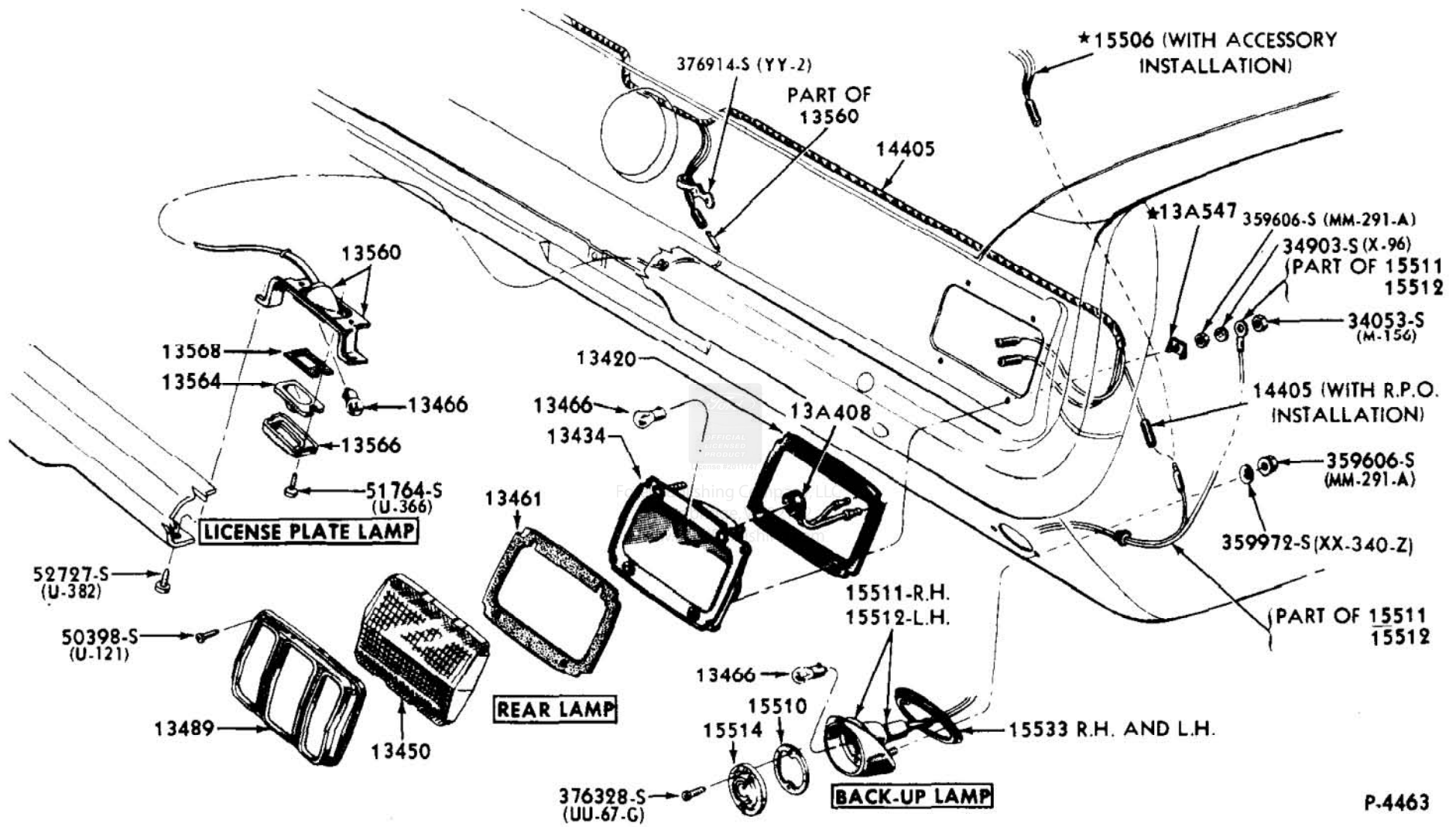

REAR LAMP, BACK UP LAMP, AND LICENSE PLATE LAMP
1965 / 66 MUSTANG

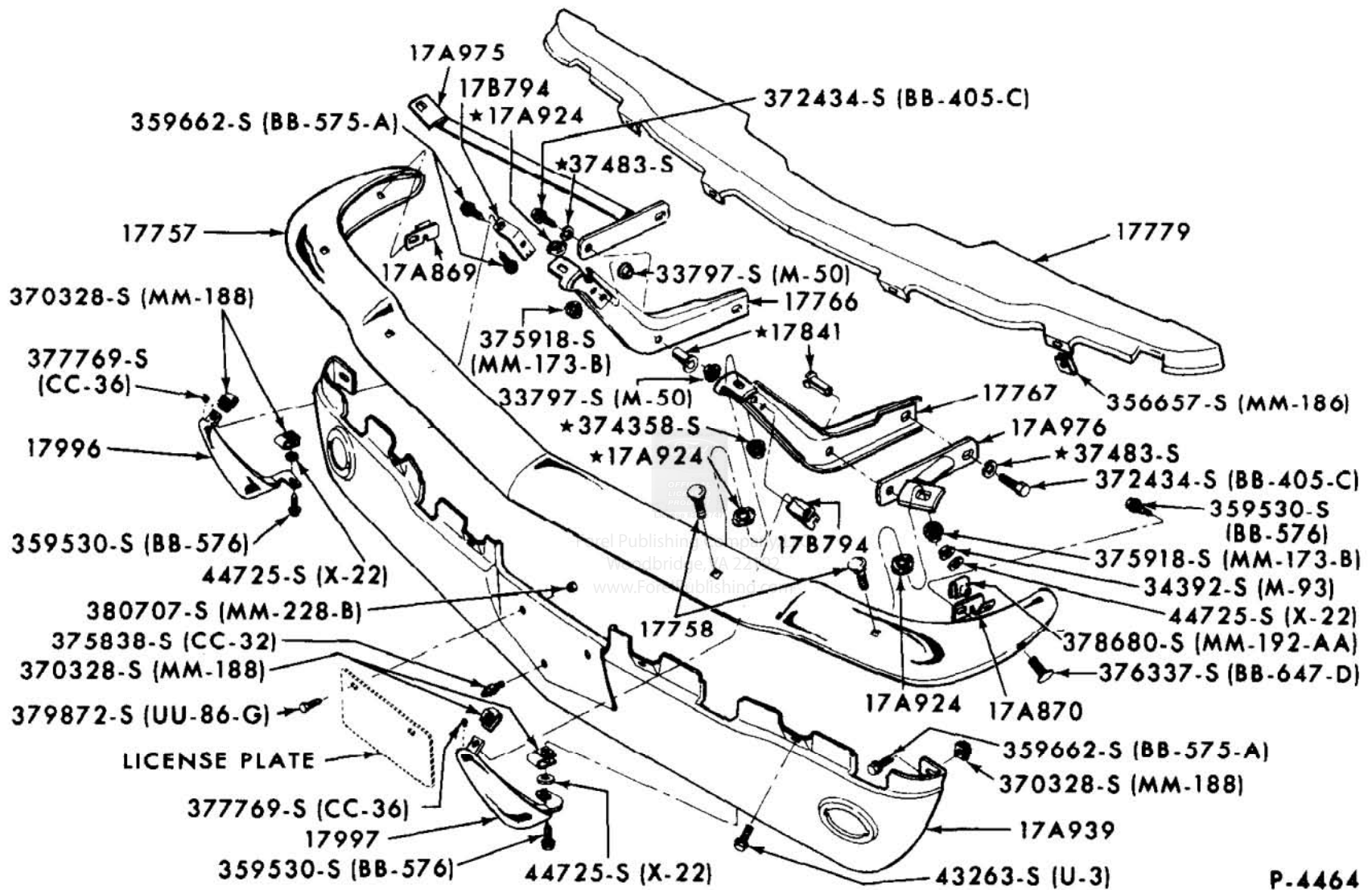

P-4464

FRONT BUMPER AND RELATED PARTS
1965 / 66 MUSTANG

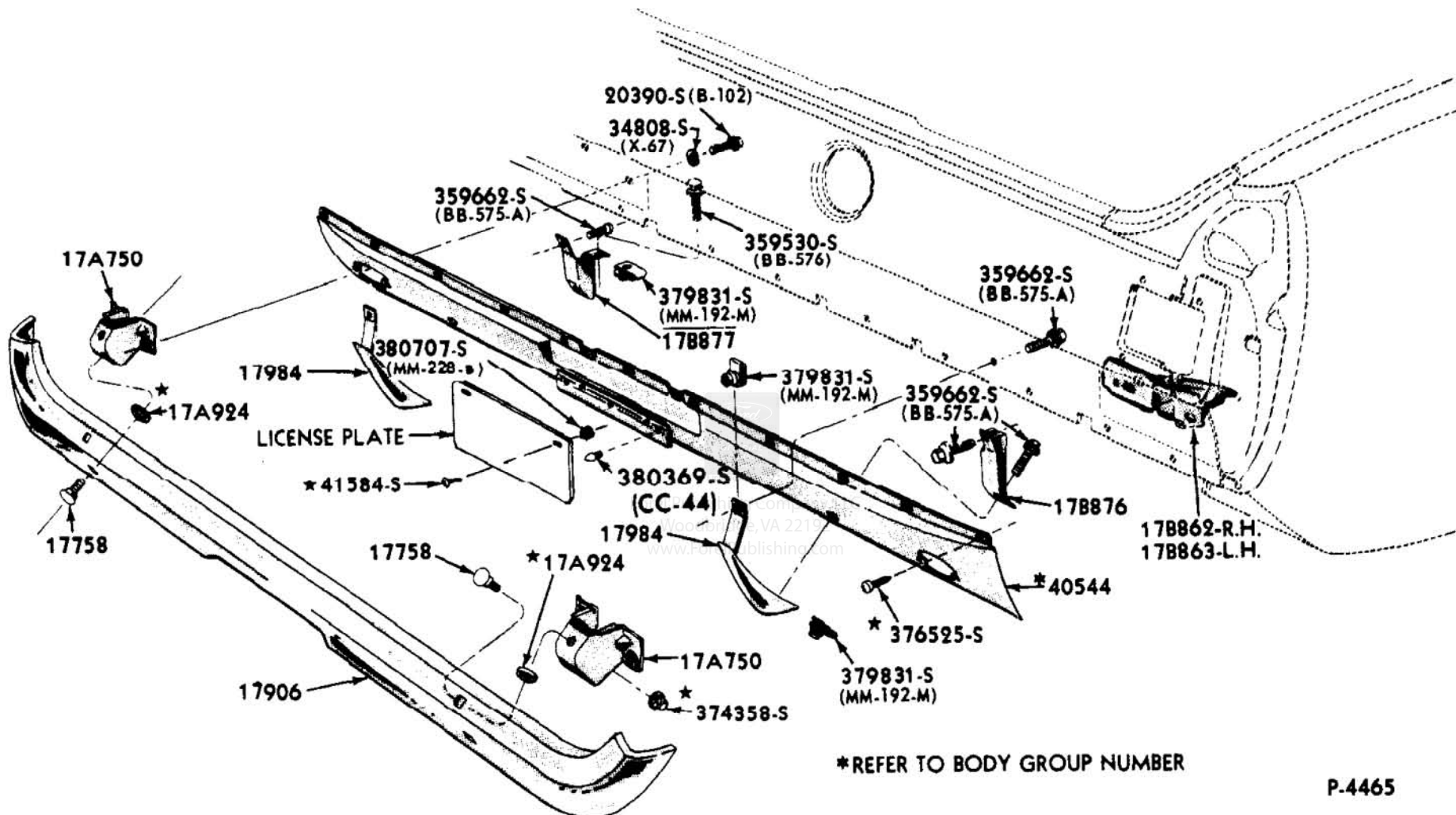

P-4465

REAR BUMPER AND RELATED PARTS
1965 / 66 MUSTANG

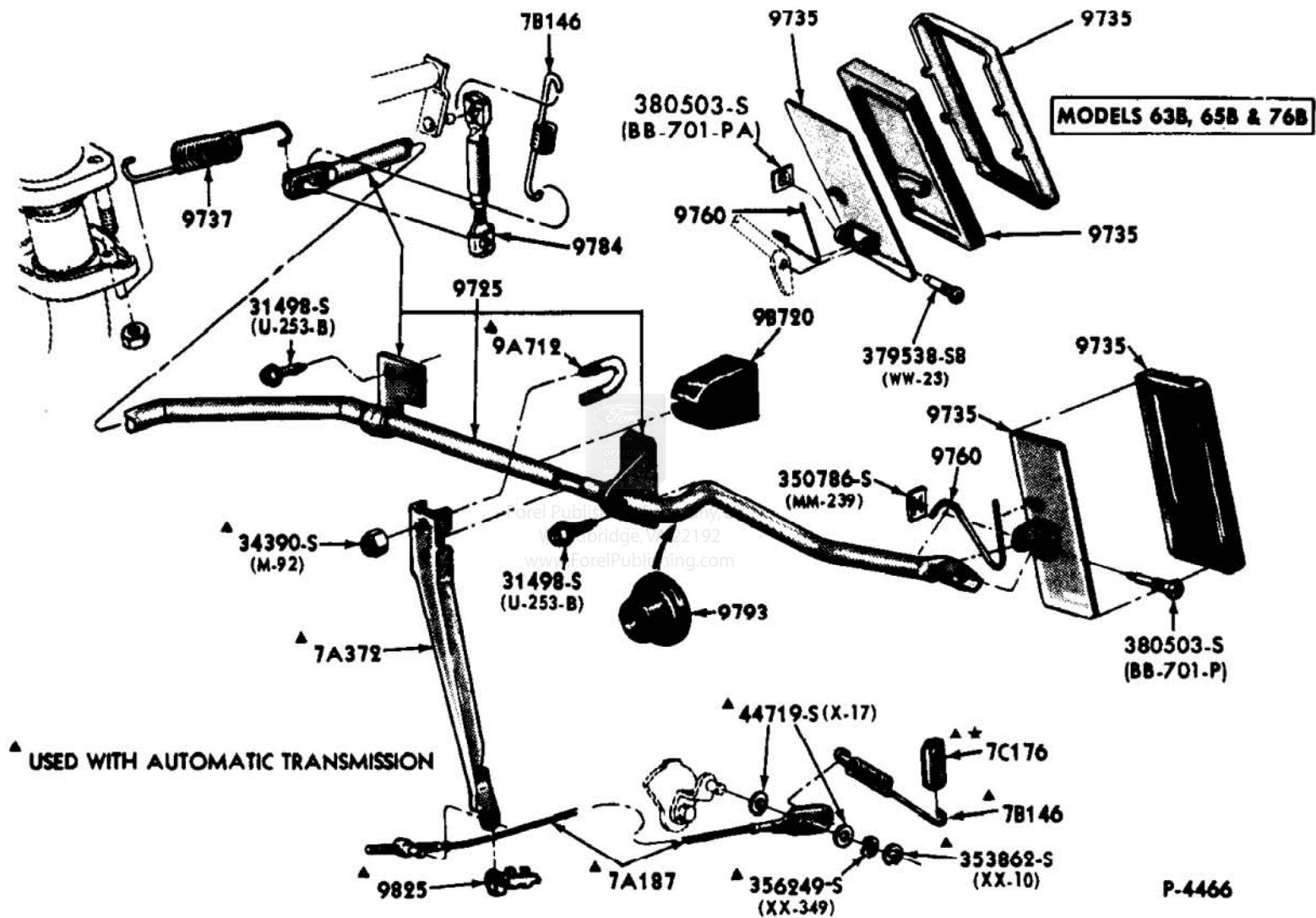

ACCELERATOR LINKAGE
1965 / 66 MUSTANG (6 CYLINDER 170, 200 ENGINES)

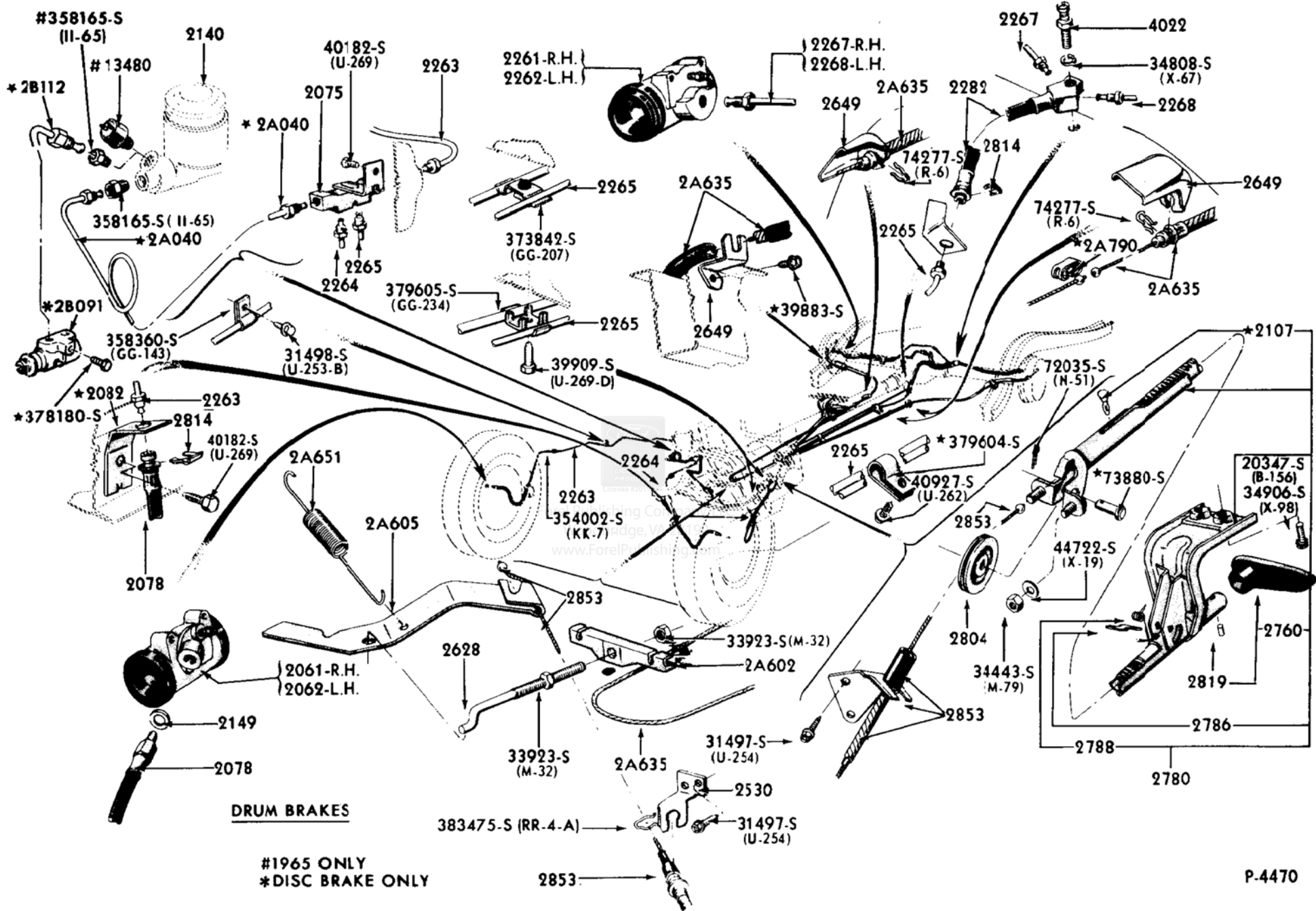

DRUM BRAKES

#1965 ONLY
 *DISC BRAKE ONLY

P-4470

DISC, DRUM & PARKING BRAKE SYSTEM
1965/66 MUSTANG

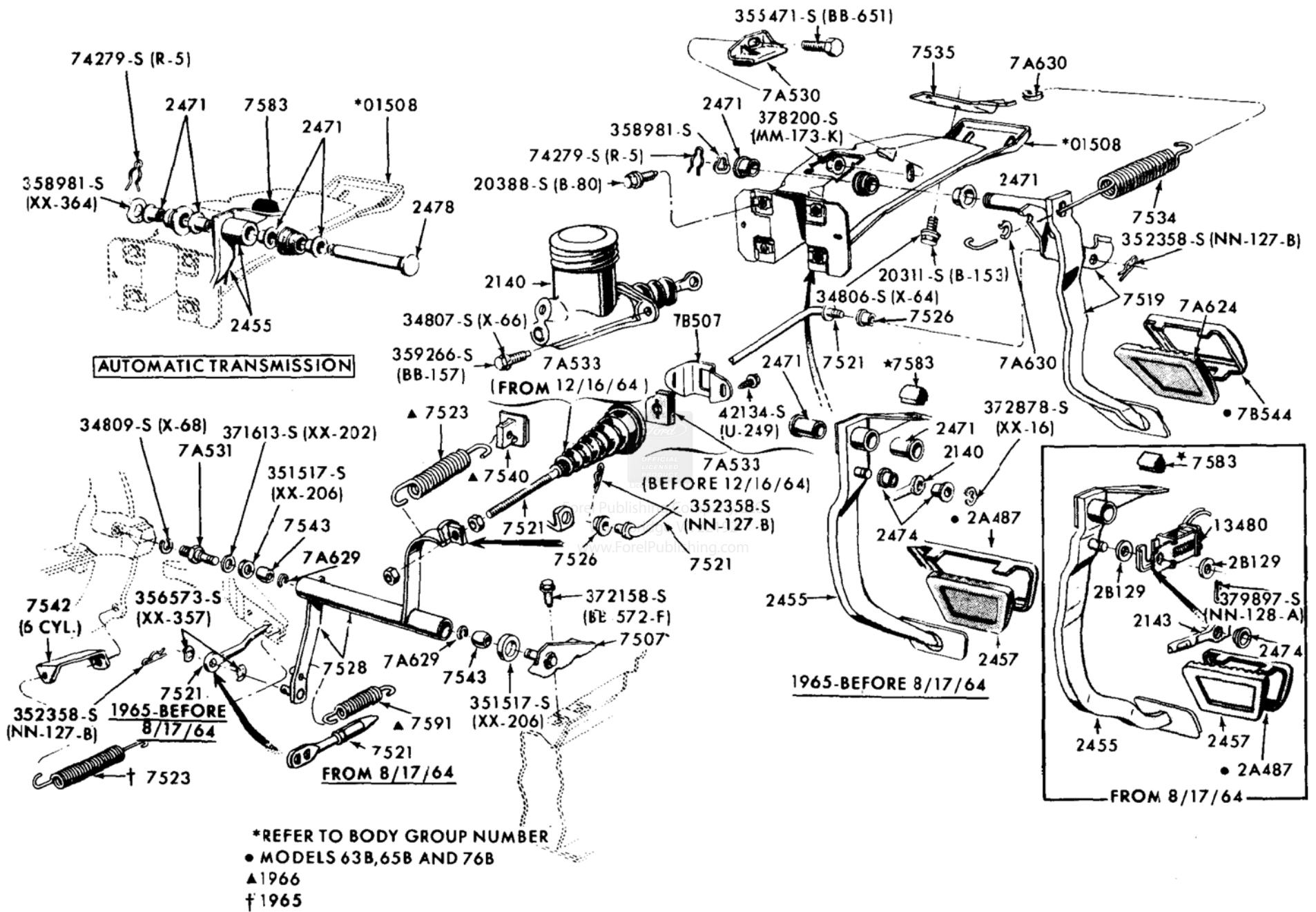

**CLUTCH PEDAL AND BRAKE PEDAL
 1965/66 MUSTANG**

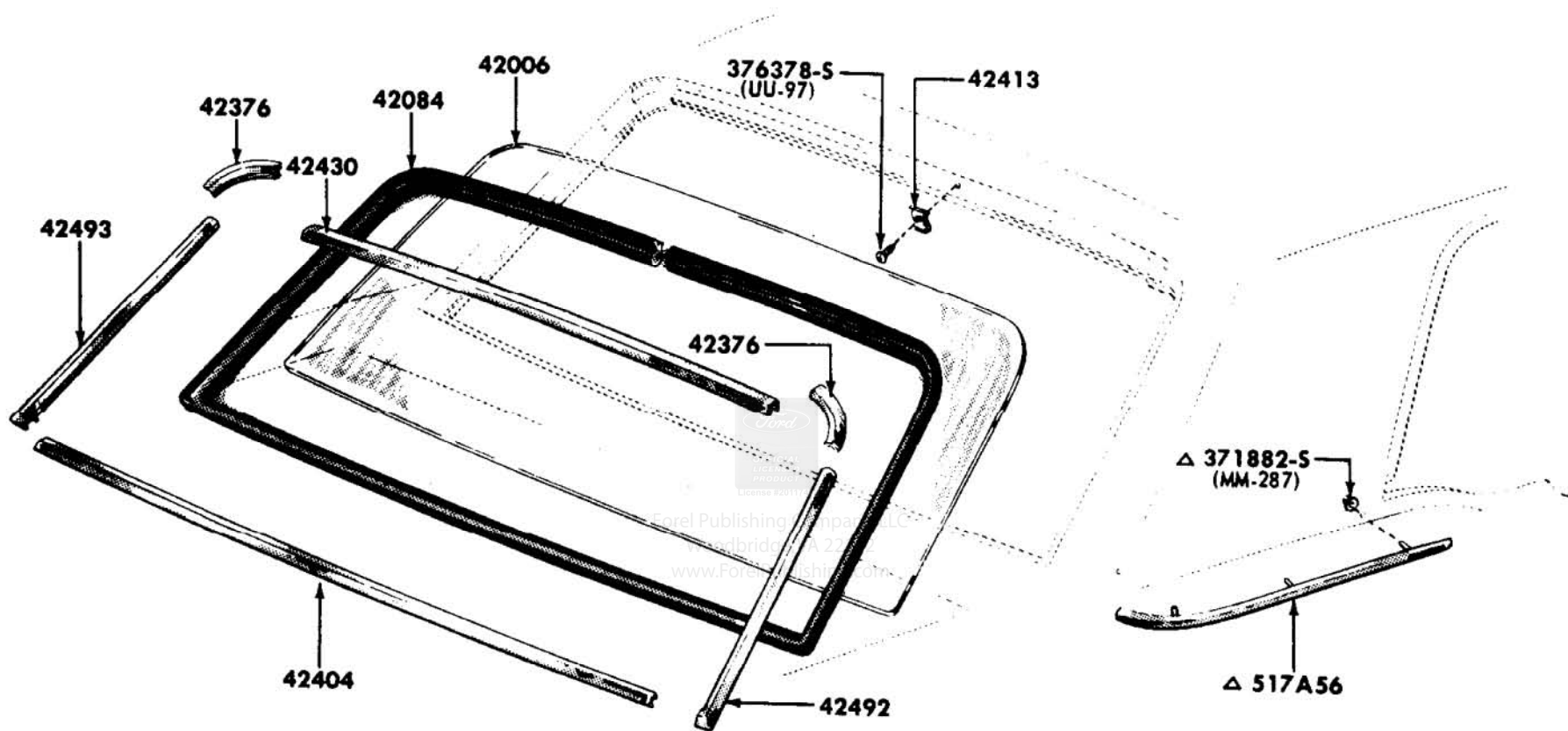

Δ USED WITH VINYL ROOF COVER OR TUTONE PAINT

P-4476

**BACK WINDOW AND RELATED PARTS
1965 / 66 MUSTANG - BODY TYPE 65**

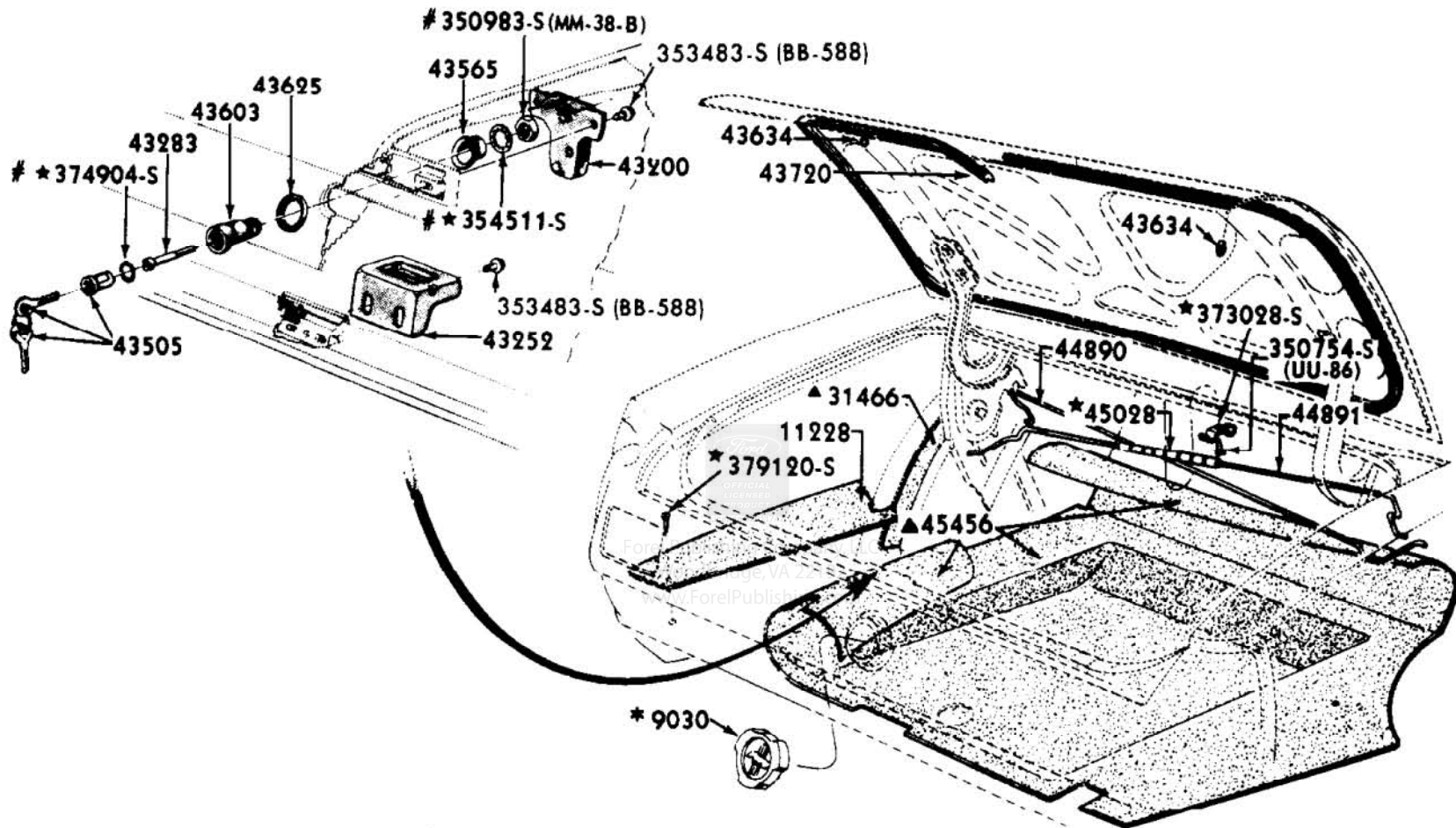

- * REFER TO GROUP IN CHASSIS SECTION
- ▲ REFER TO GROUP IN SOFT TRIM SECTION
- # ALSO SERVICED IN ASSEMBLY—GROUP 43603

P-4477

**LUGGAGE COMPARTMENT DOOR LATCH AND RELATED PARTS
 1965 / 66 MUSTANG - BODY TYPES 65, 76**

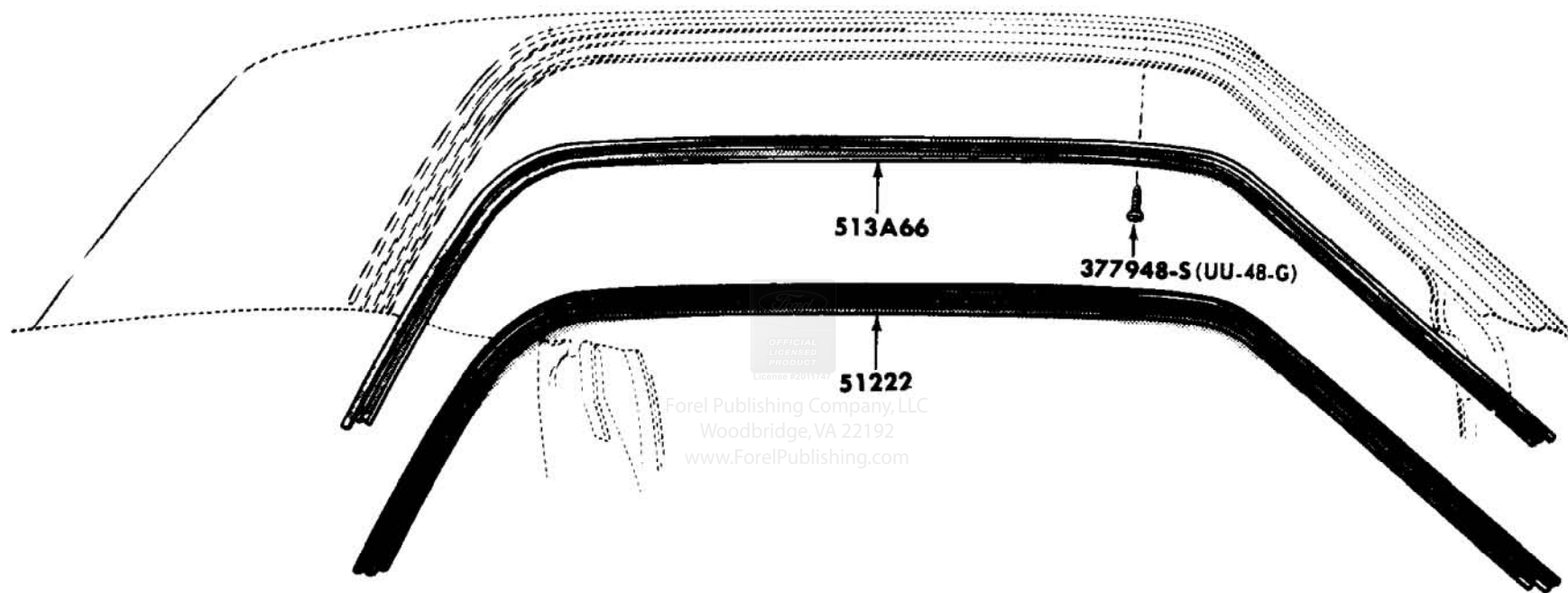

OFFICIAL LICENSED PRODUCT

513A66

377948-S (UU-48.G)

51222

Forel Publishing Company, LLC
Woodbridge, VA 22192
www.ForelPublishing.com

P-4478

ROOF SIDE MOULDINGS AND WEATHERSTRIPS
1965 / 66 MUSTANG - BODY TYPE 65

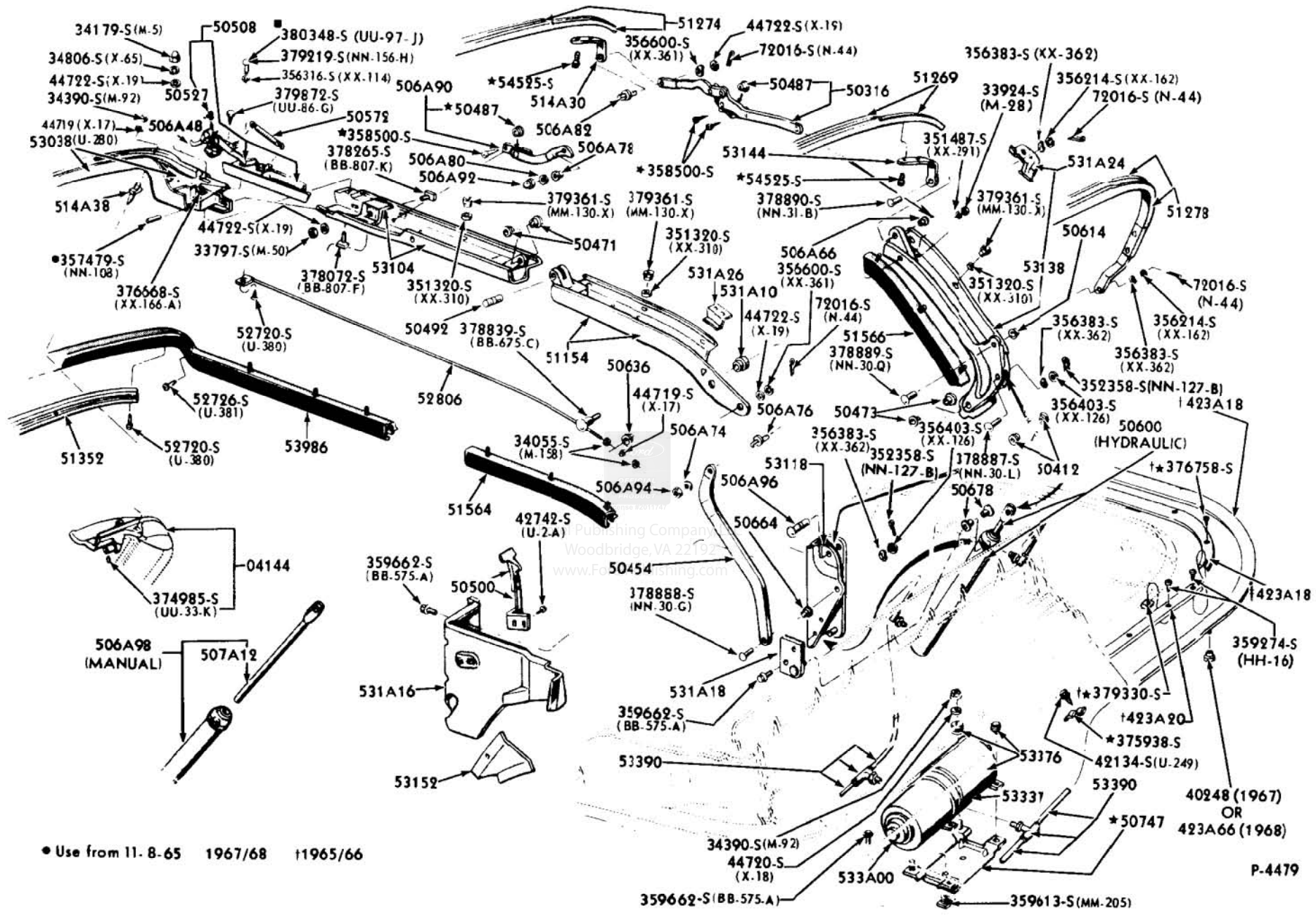

FOLDING TOP PARTS - LESS TRIM
1965 / 68 MUSTANG - BODY TYPE 76 - TYPICAL

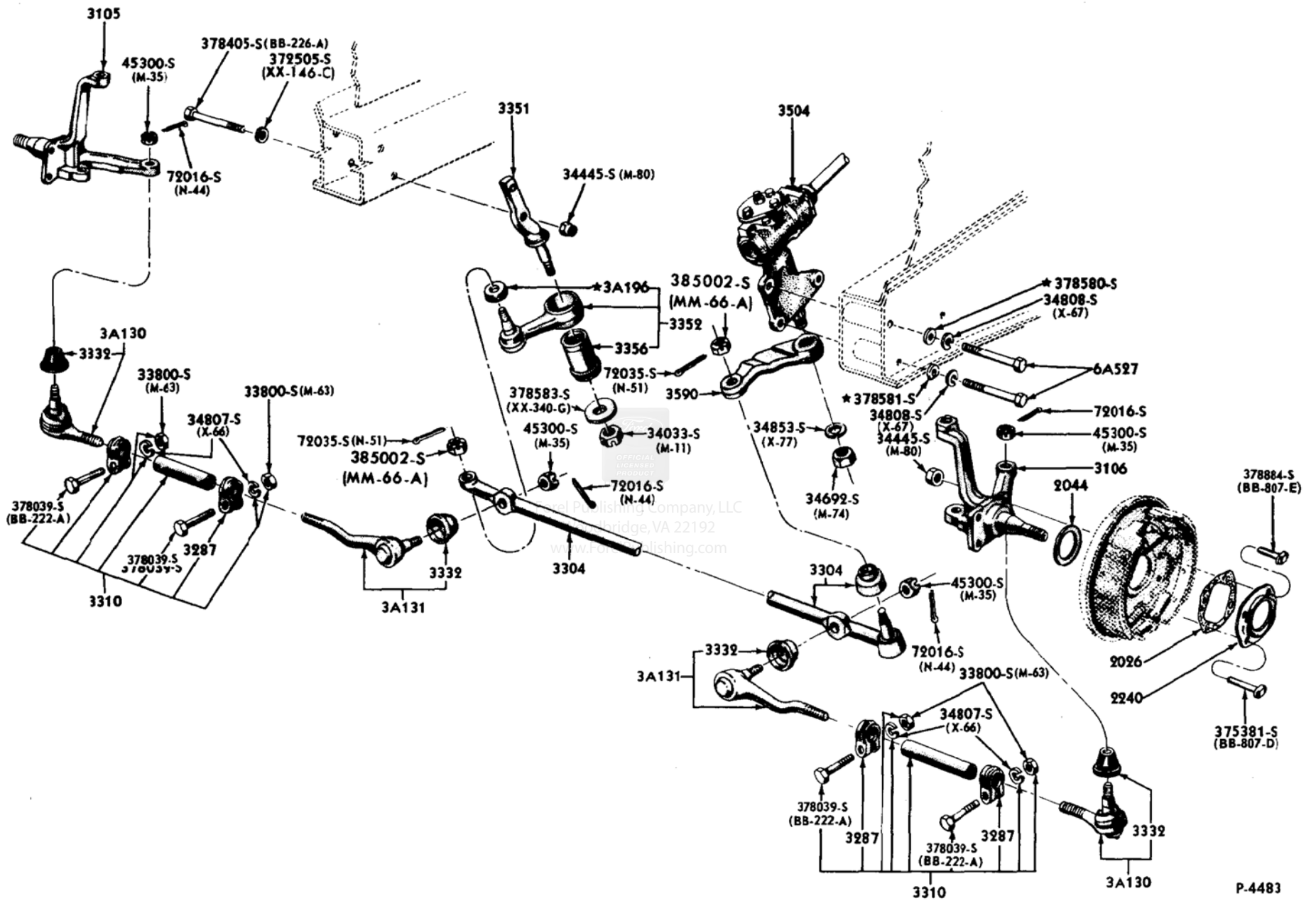

MANUAL STEERING LINKAGE - 8 CYLINDER
1965 FALCON, 1965 / 66 MUSTANG

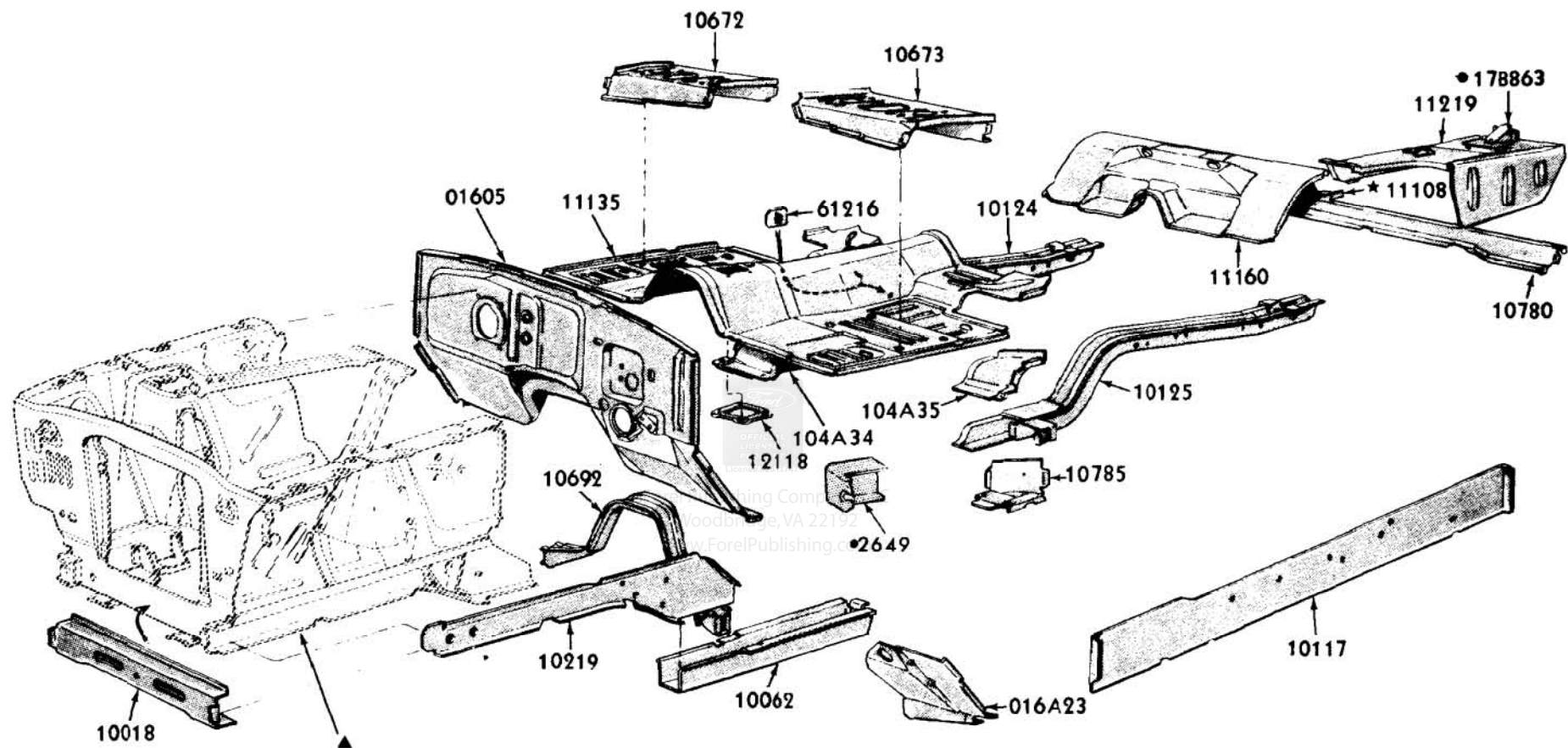

- ▲ REFER TO CHASSIS ILLUSTRATION SECTION 160 FOR EXPLODED VIEW INFORMATION
- REFER TO CHASSIS GROUP

P-4486

1965 / 66 MUSTANG - BODY TYPE 63, 65 - UNDER BODY

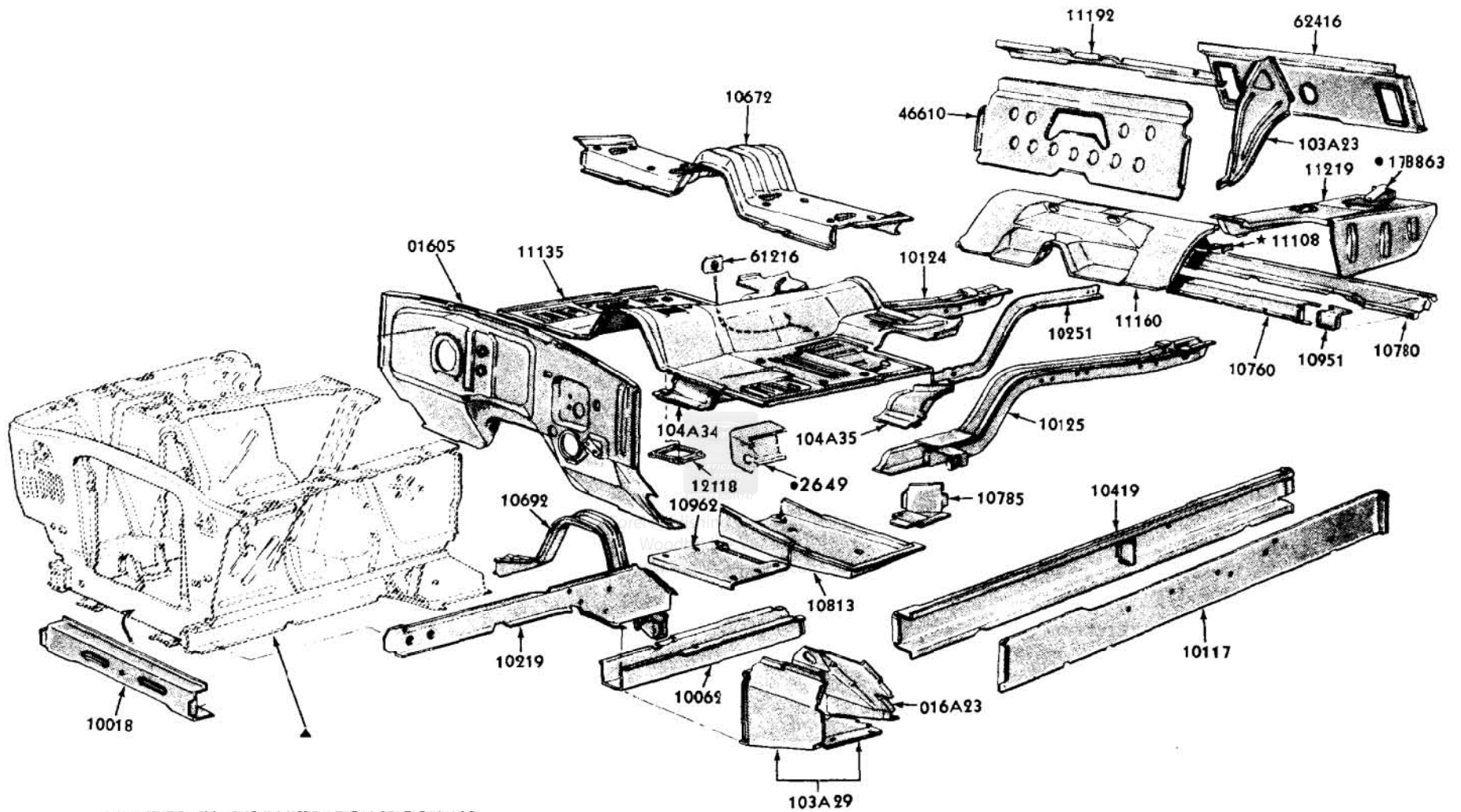

▲ REFER TO CHASSIS ILLUSTRATION SECTION 160
 FOR EXPLODED VIEW INFORMATION
 ● REFER TO CHASSIS GROUP

P.4487

1965 / 66 MUSTANG - BODY TYPE 76 - UNDER BODY

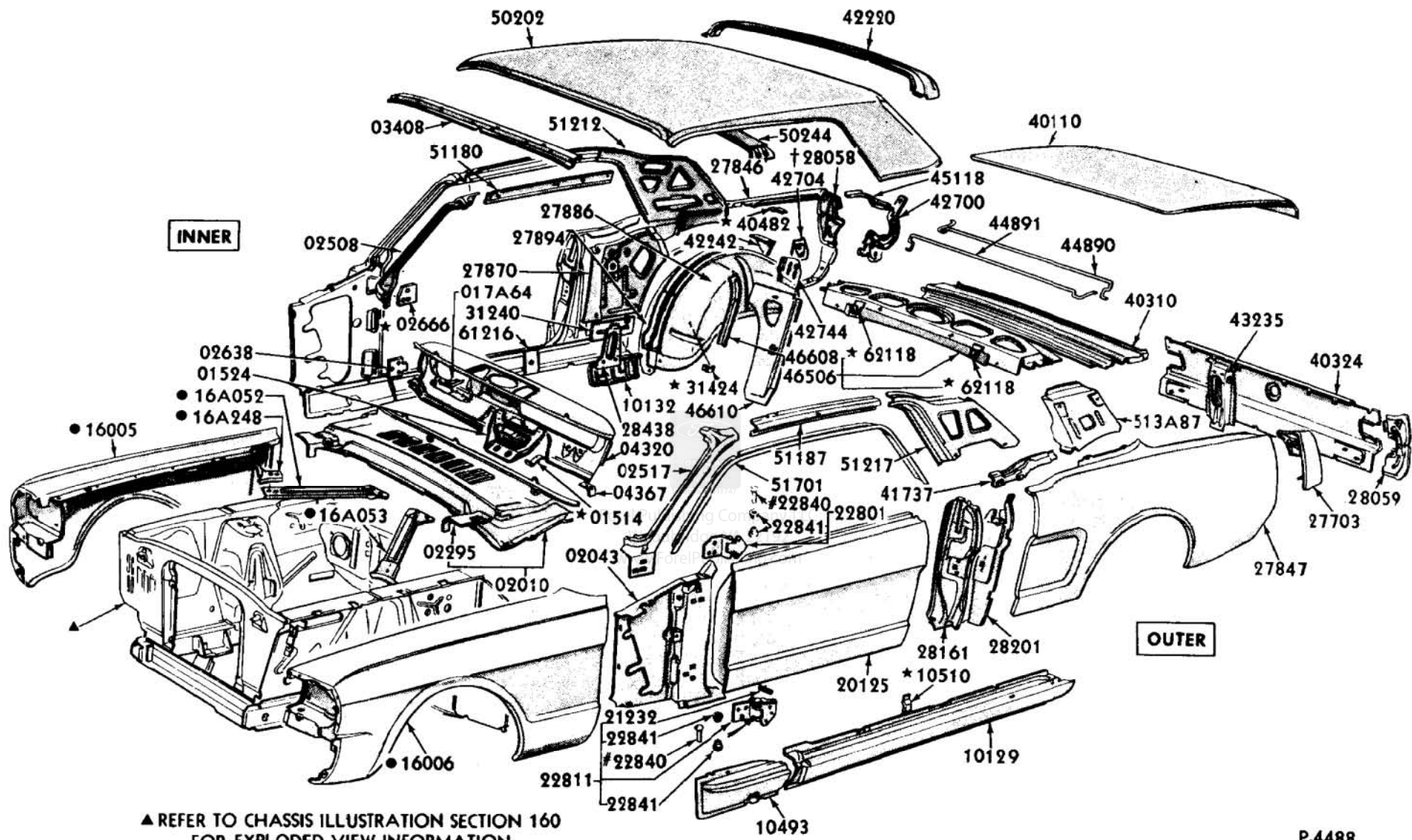

▲ REFER TO CHASSIS ILLUSTRATION SECTION 160 FOR EXPLODED VIEW INFORMATION

● REFER TO CHASSIS GROUP

† ALSO INCLUDED IN 27846-7

REFER TO GROUP 43030 IN TEXT PAGES

P-4488

1965 / 66 MUSTANG - BODY TYPE 65 - UPPER BODY

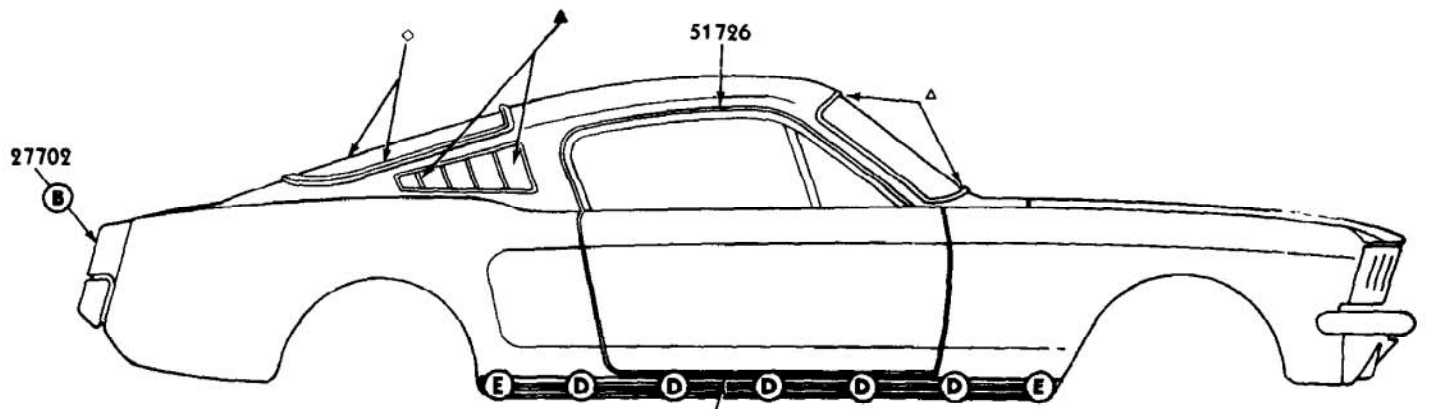

*16229 10176 BODY TYPE 63

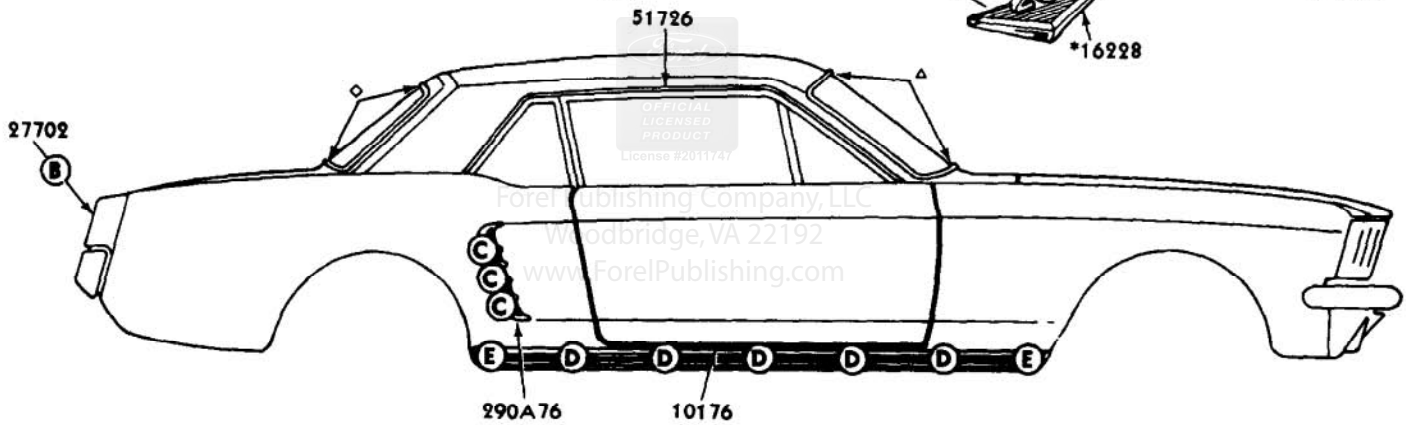
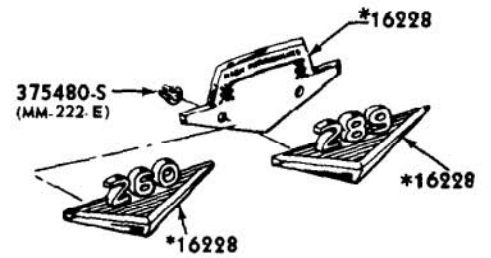
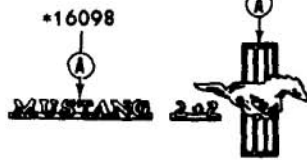

BODY TYPE 65, 76

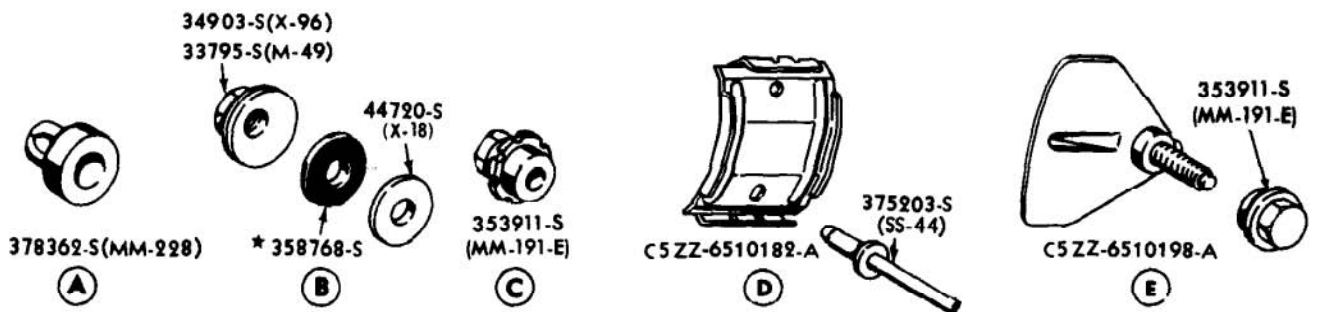

- ▲ REFER TO BODY ILLUSTRATION SECTION 030
- ◇ REFER TO BODY ILLUSTRATION SECTION 400
- * REFER TO GROUP IN CHASSIS SECTION

P-4490

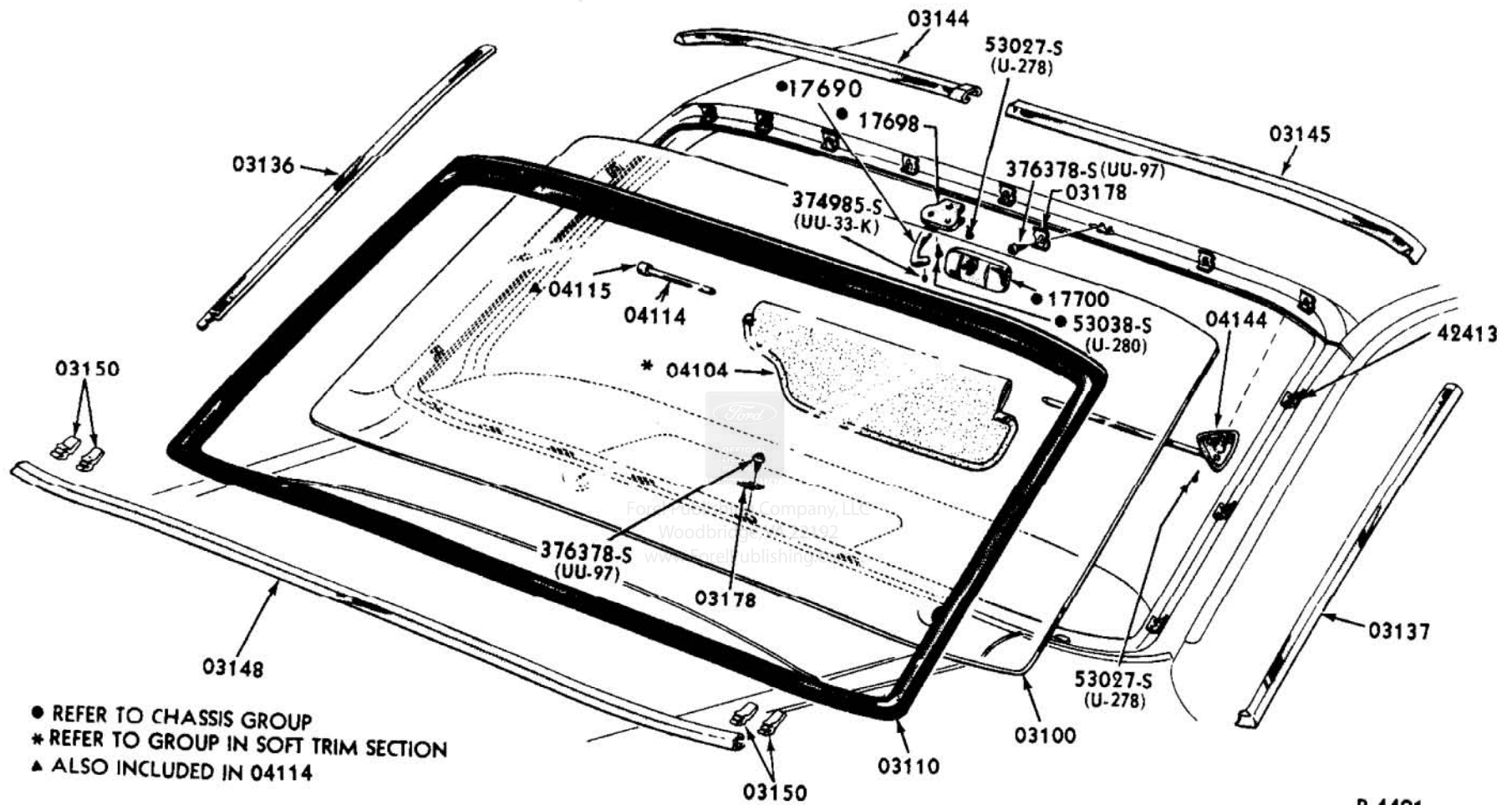

WINDSHIELD AND RELATED PARTS
1965 / 68 MUSTANG - BODY TYPES 63, 65

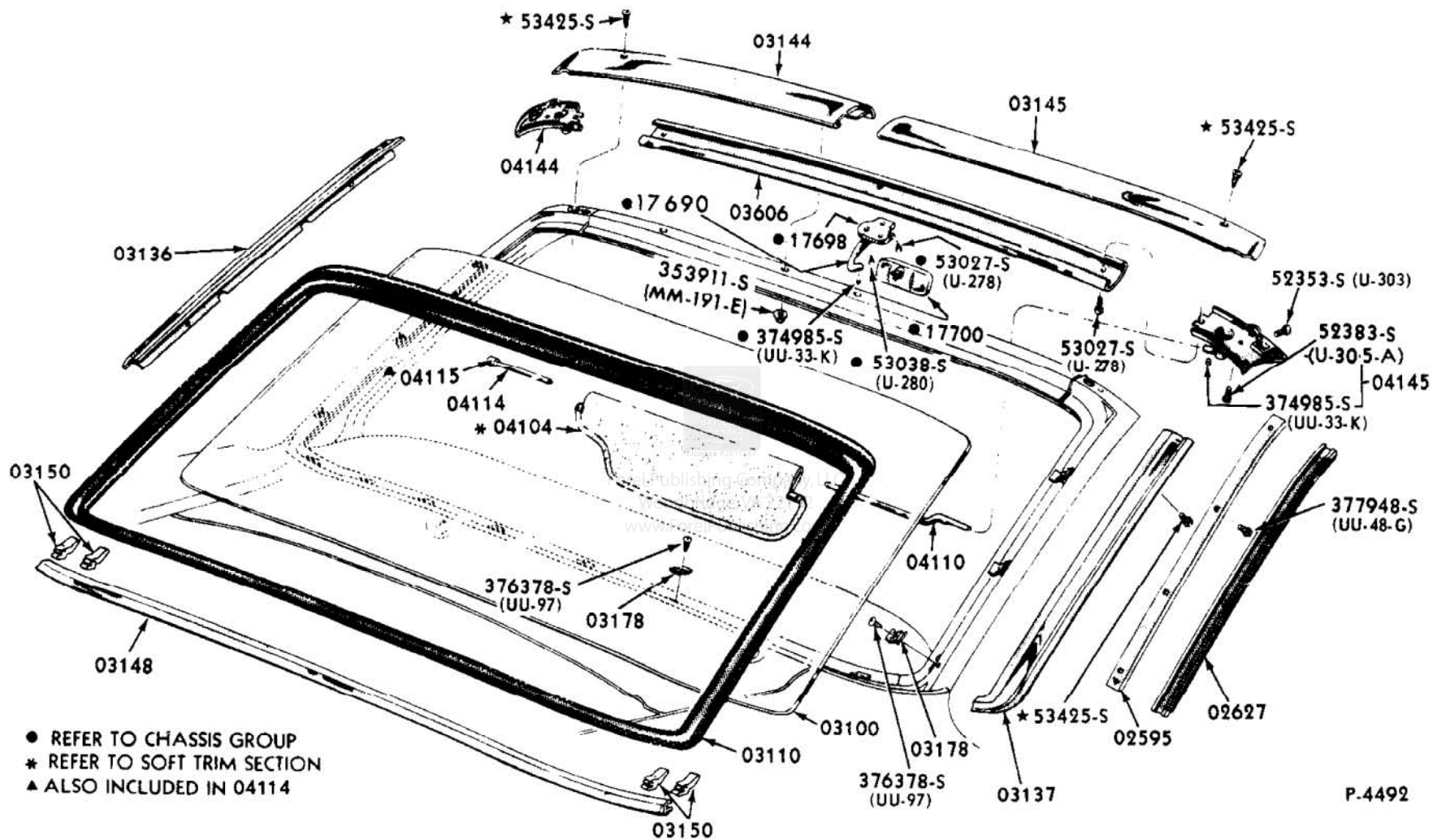

P.4492

WINDSHIELD AND RELATED PARTS
1965 / 68 MUSTANG - BODY TYPE 76

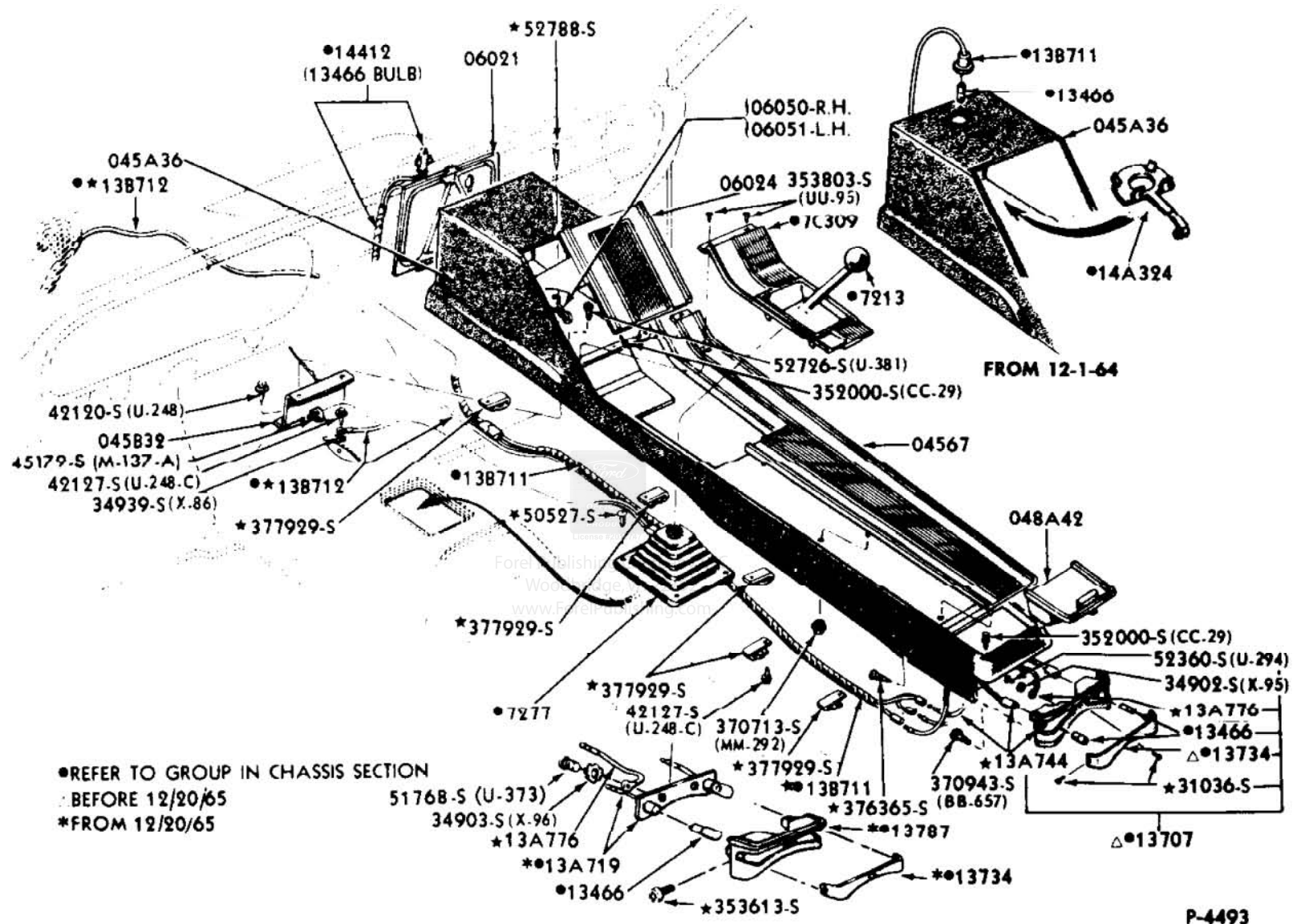

CONSOLE AND RELATED PARTS
 1965 / 66 MUSTANG (WITHOUT A/C)

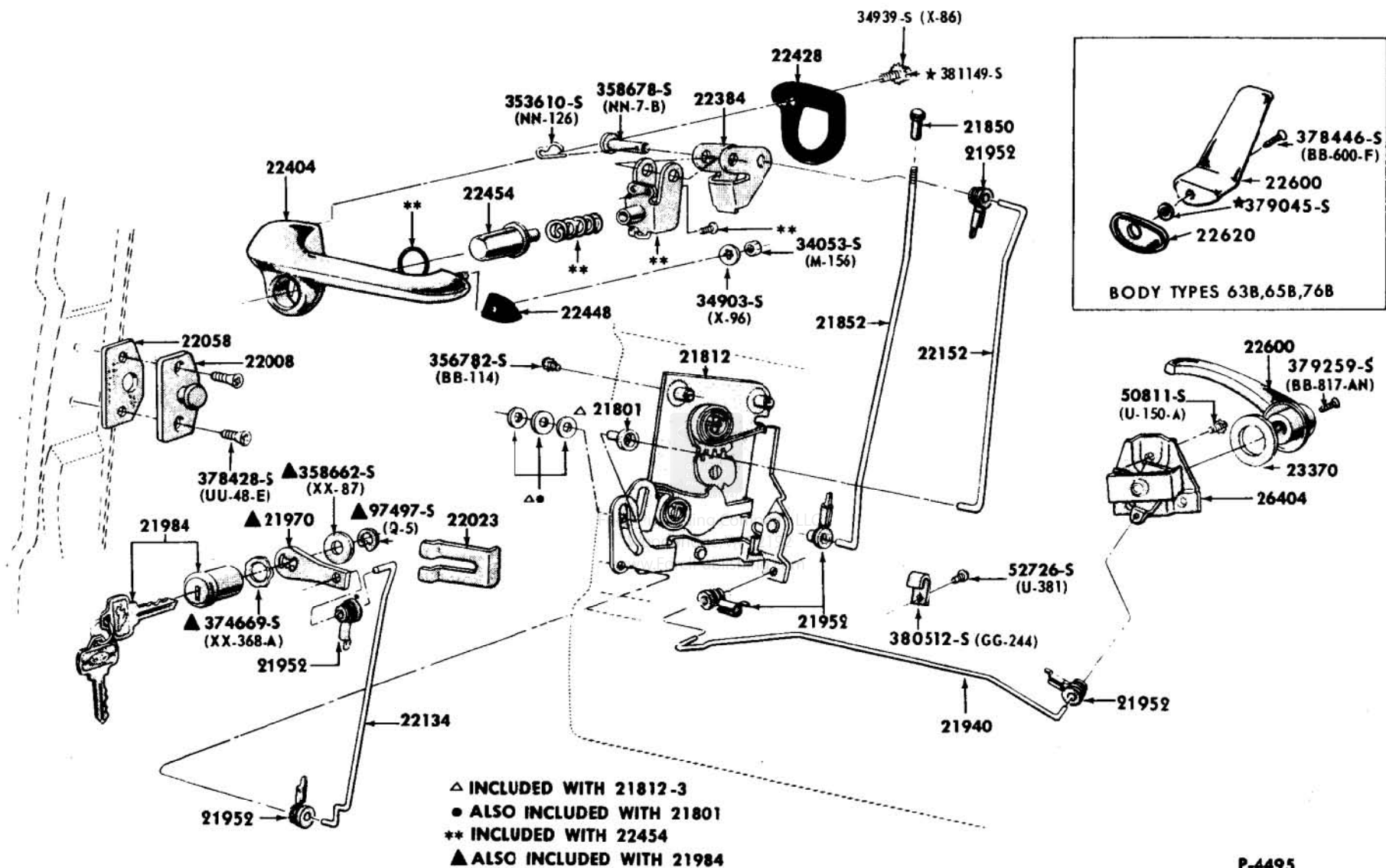

P-4495

FRONT DOOR HANDLES, LATCH AND RELATED PARTS
1965 / 66 MUSTANG

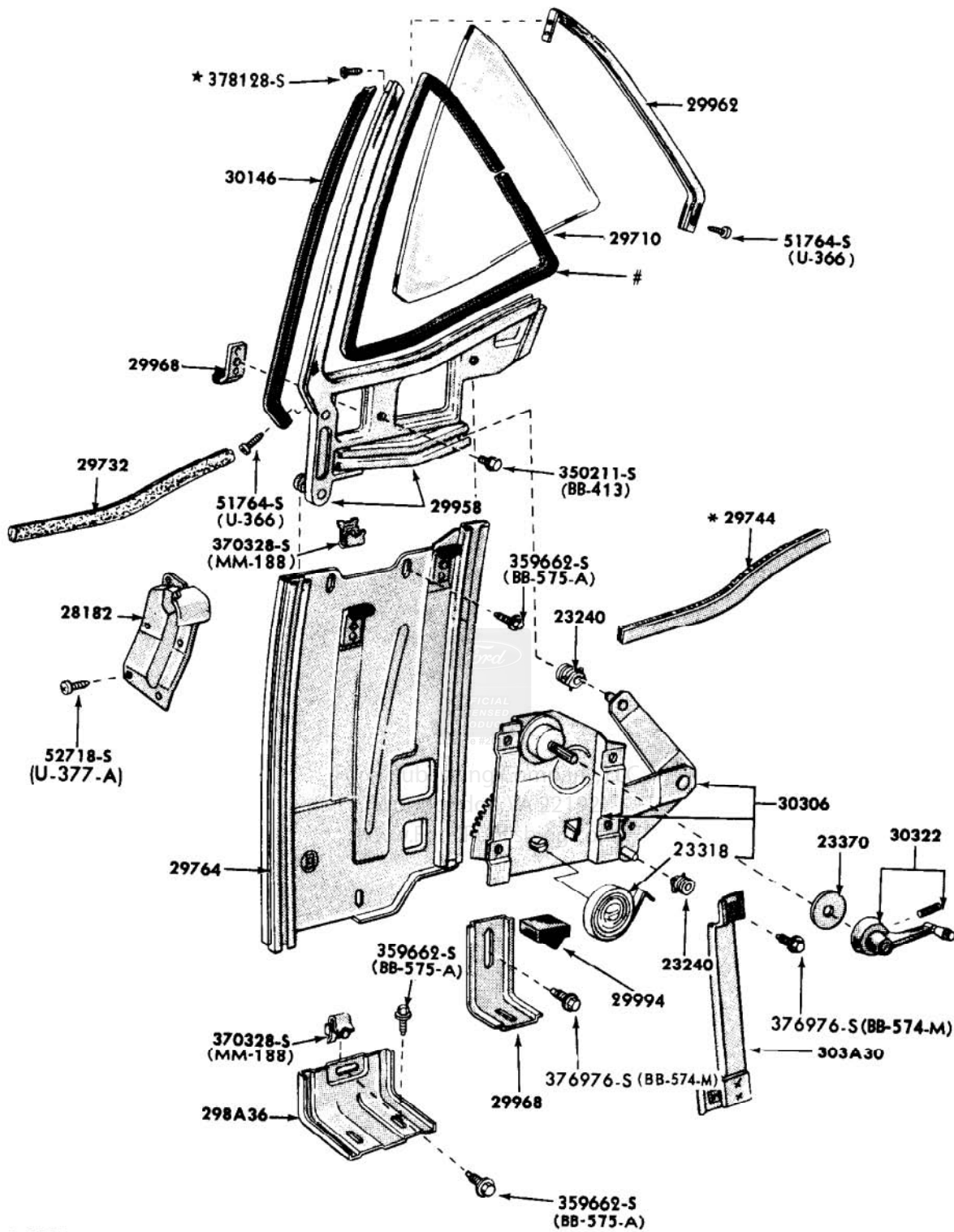

* ALSO INCLUDED WITH 31136-7

USE BULK GLASS TAPE

**QUARTER WINDOW AND RELATED PARTS
1965 / 66 MUSTANG - BODY TYPES 65, 76**

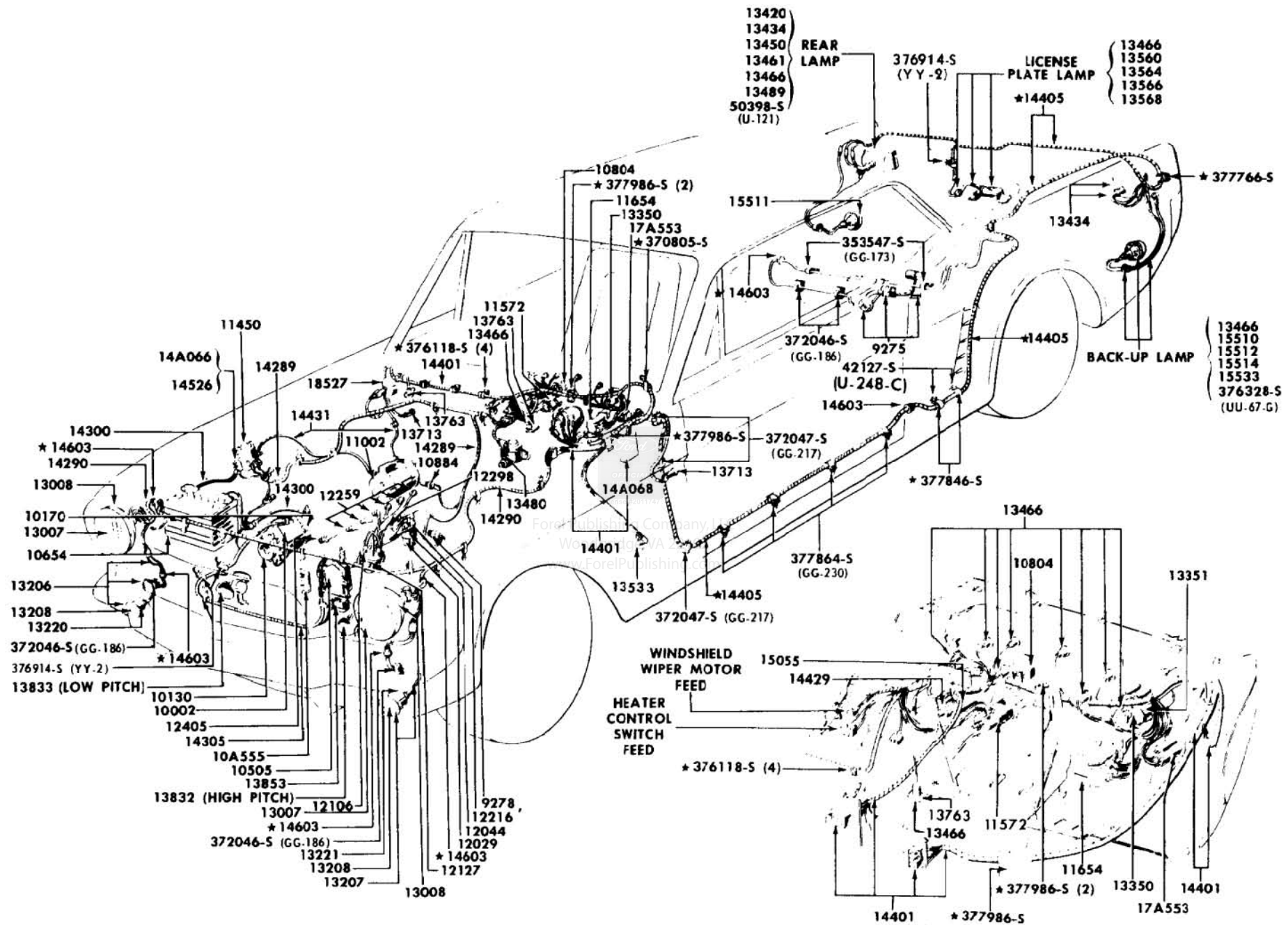

WIRING SYSTEM - "TYPICAL"
1965 / 66 MUSTNG

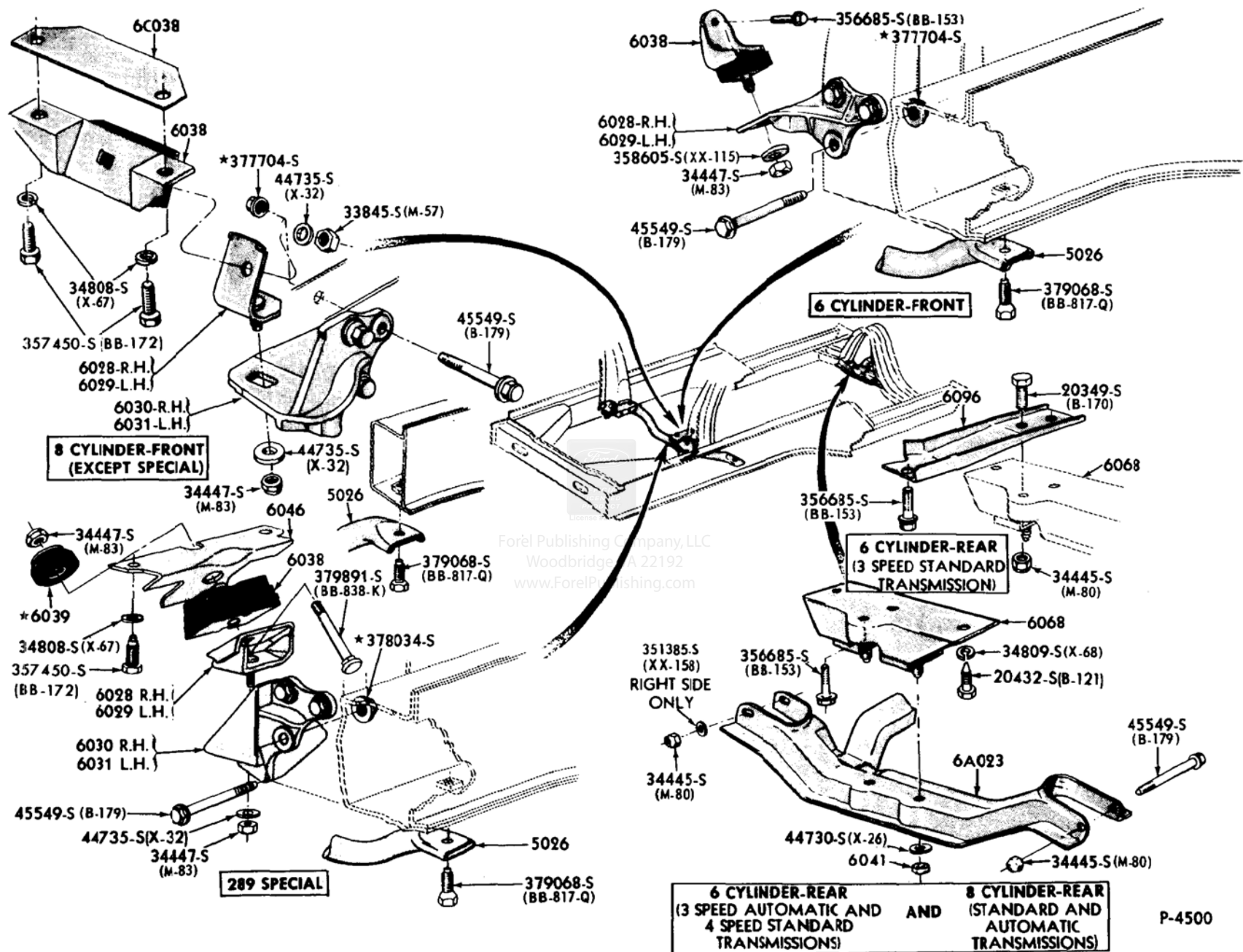

P-4500

ENGINE SUPPORTS, INSULATORS, AND RELATED PARTS -- FRONT AND REAR
1965 / 66 MUSTANG, 6 CYLINDER 170, 200 AND 8 CYLINDER 260, 289

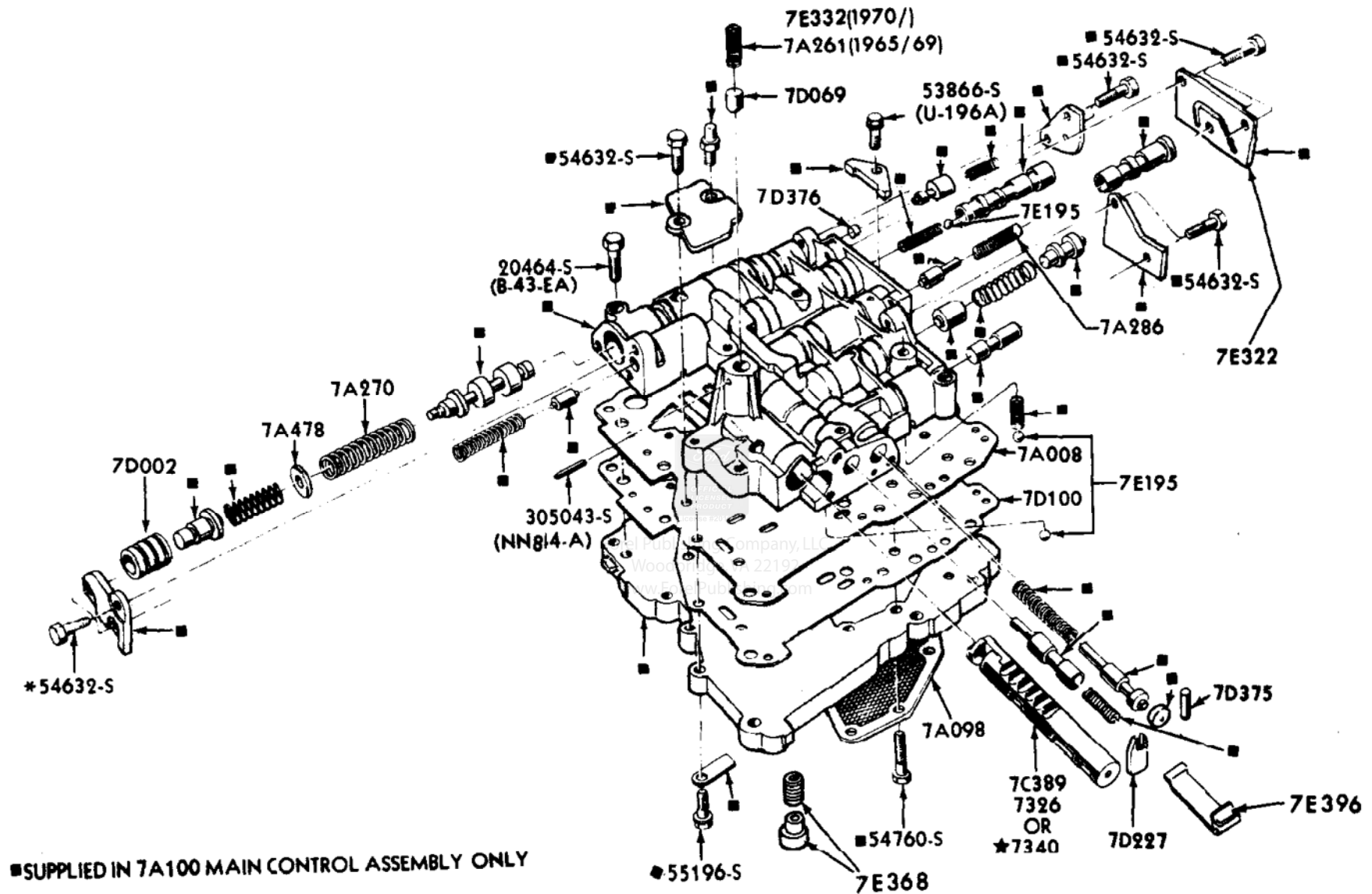

P-4507

MAIN CONTROL VALVE BODY - (BASIC 7A100) - TYPICAL
 1965 / 72 FORD, FAIRLANE / TORINO, MUSTANG & FALCON, 1970 / 72 MAVERICK, 1971 / 72 PINTO

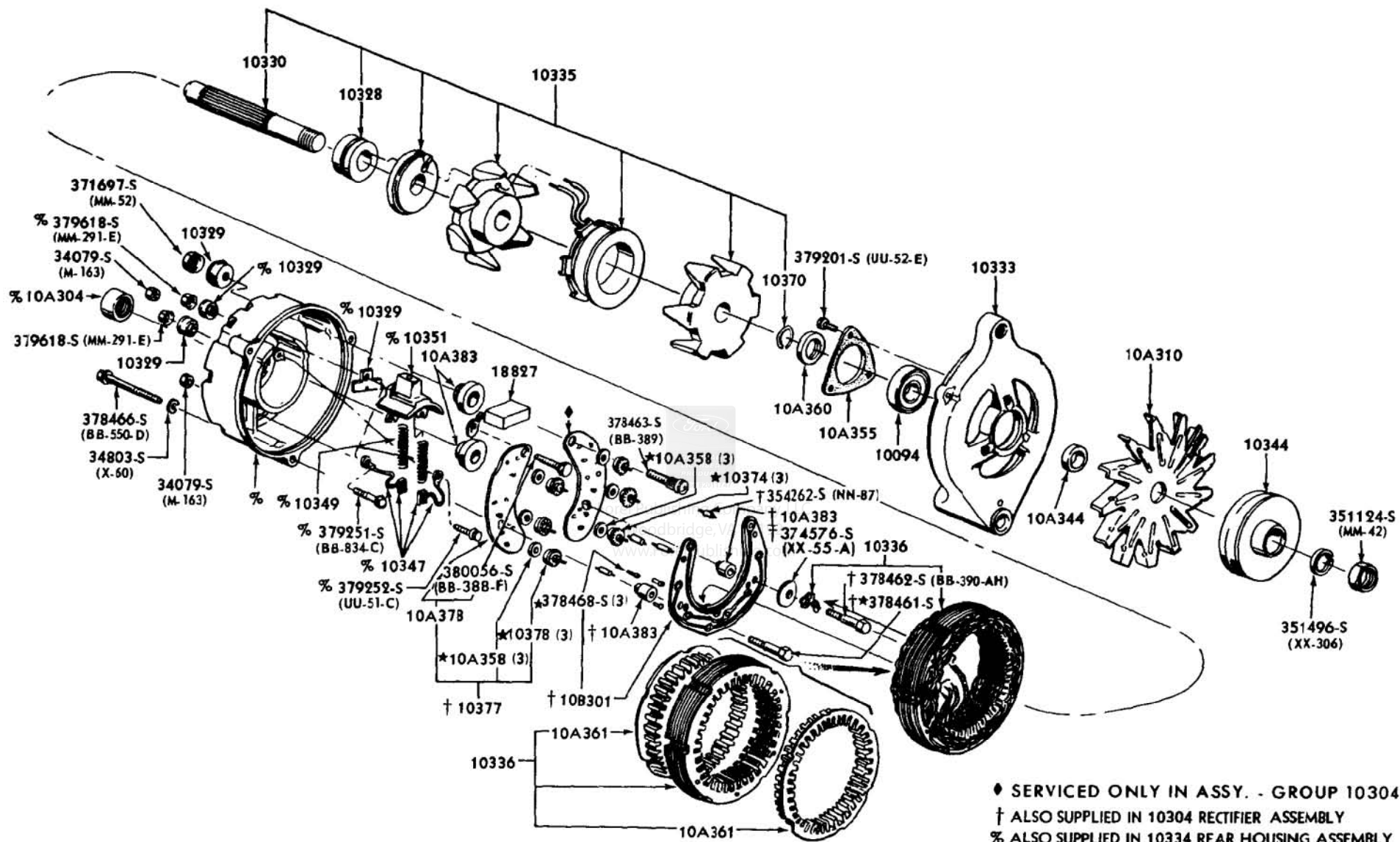

P-4508

ALTERNATOR (FORD 15 VOLT - 38, 42, 45, 55, 60, 61 AMP.)

1965 / 72

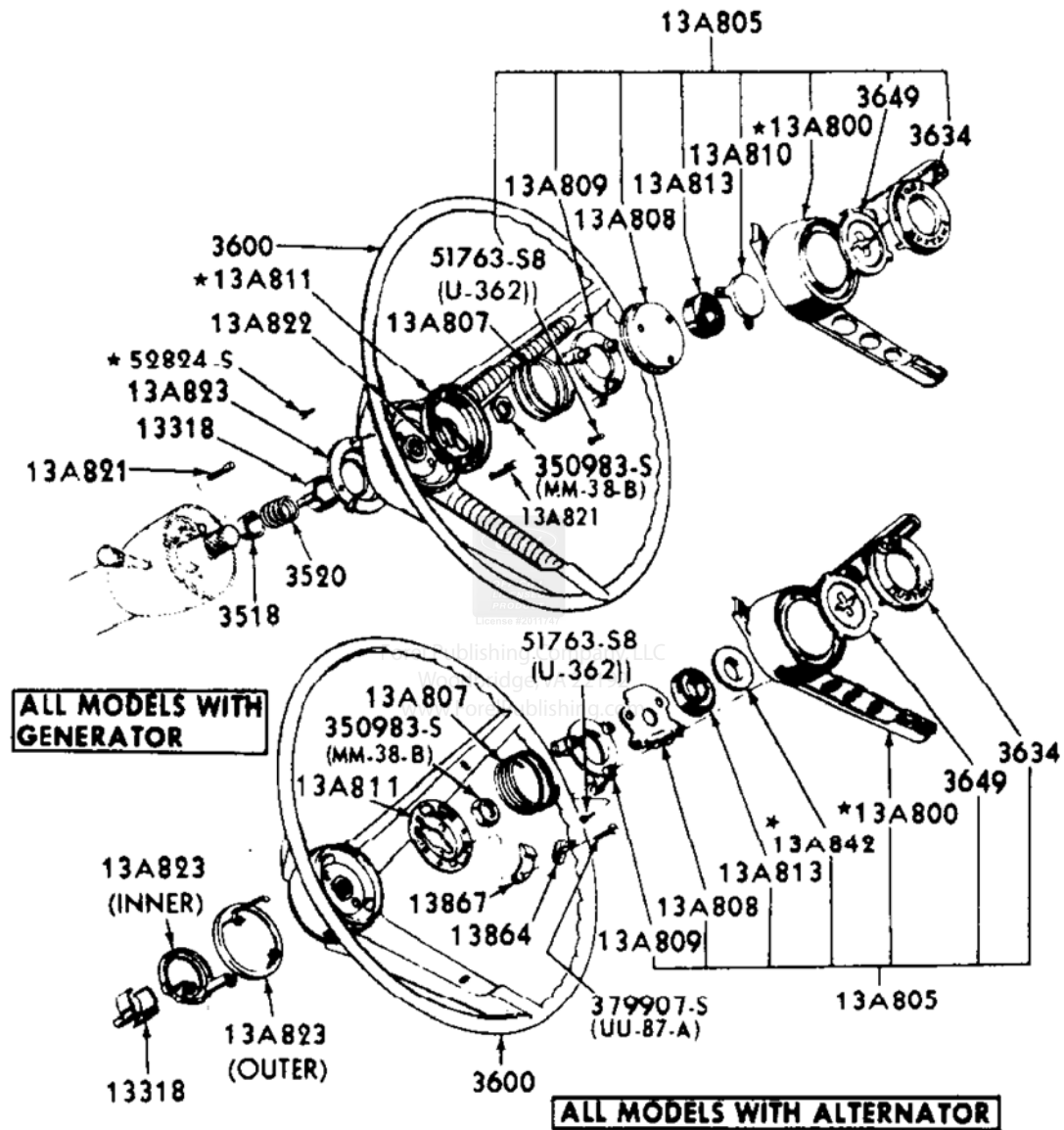

P-4514

HORN RING, STEERING WHEEL AND RELATED PARTS -- NON-WOODGRAIN WHEEL
1965/66 MUSTANG

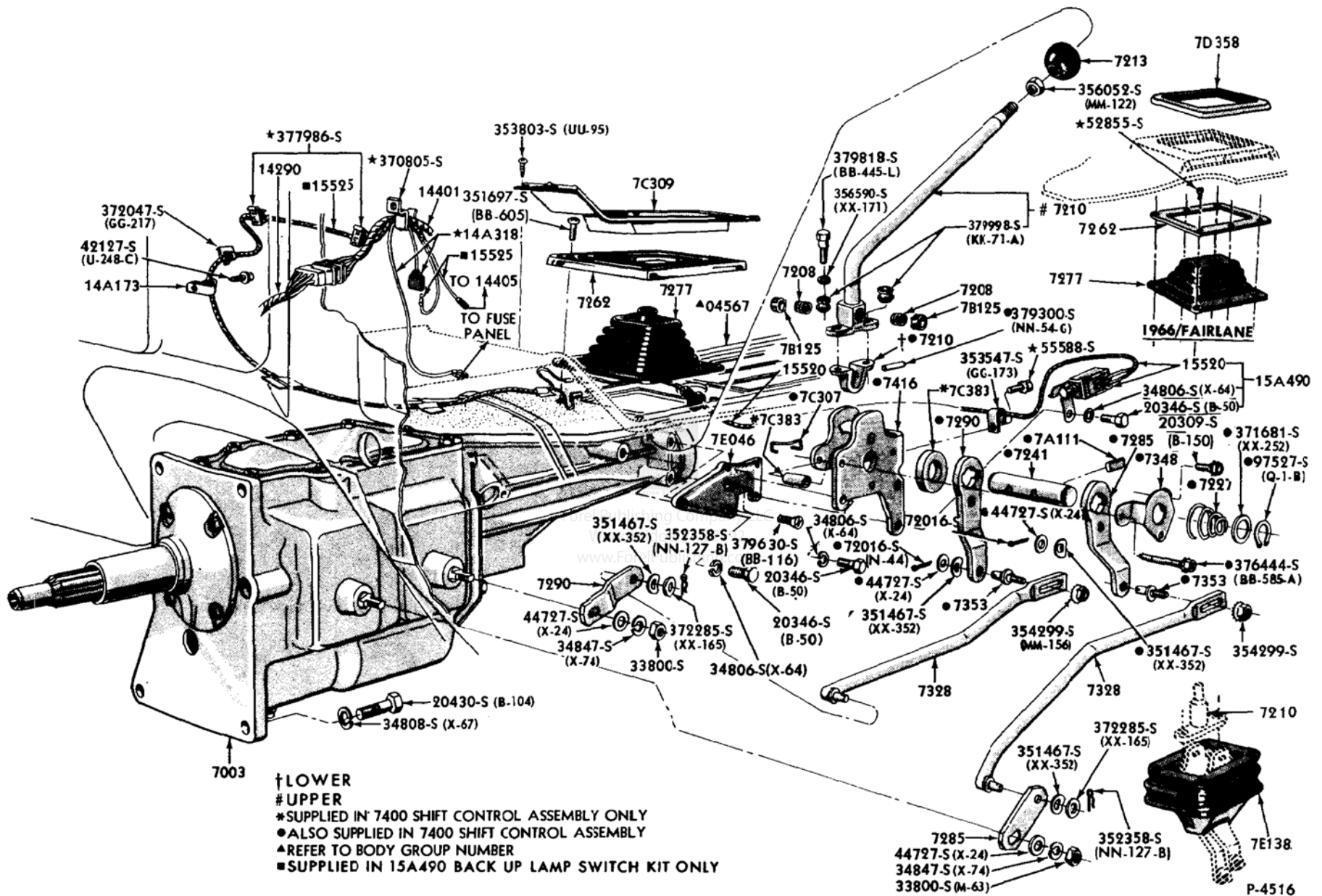

GEAR SHIFT MECHANISM - FLOOR MOUNTED
 3 SPEED MANUAL TRANSMISSION
 1965 / 68 FAIRLANE / TORINO & MUSTANG

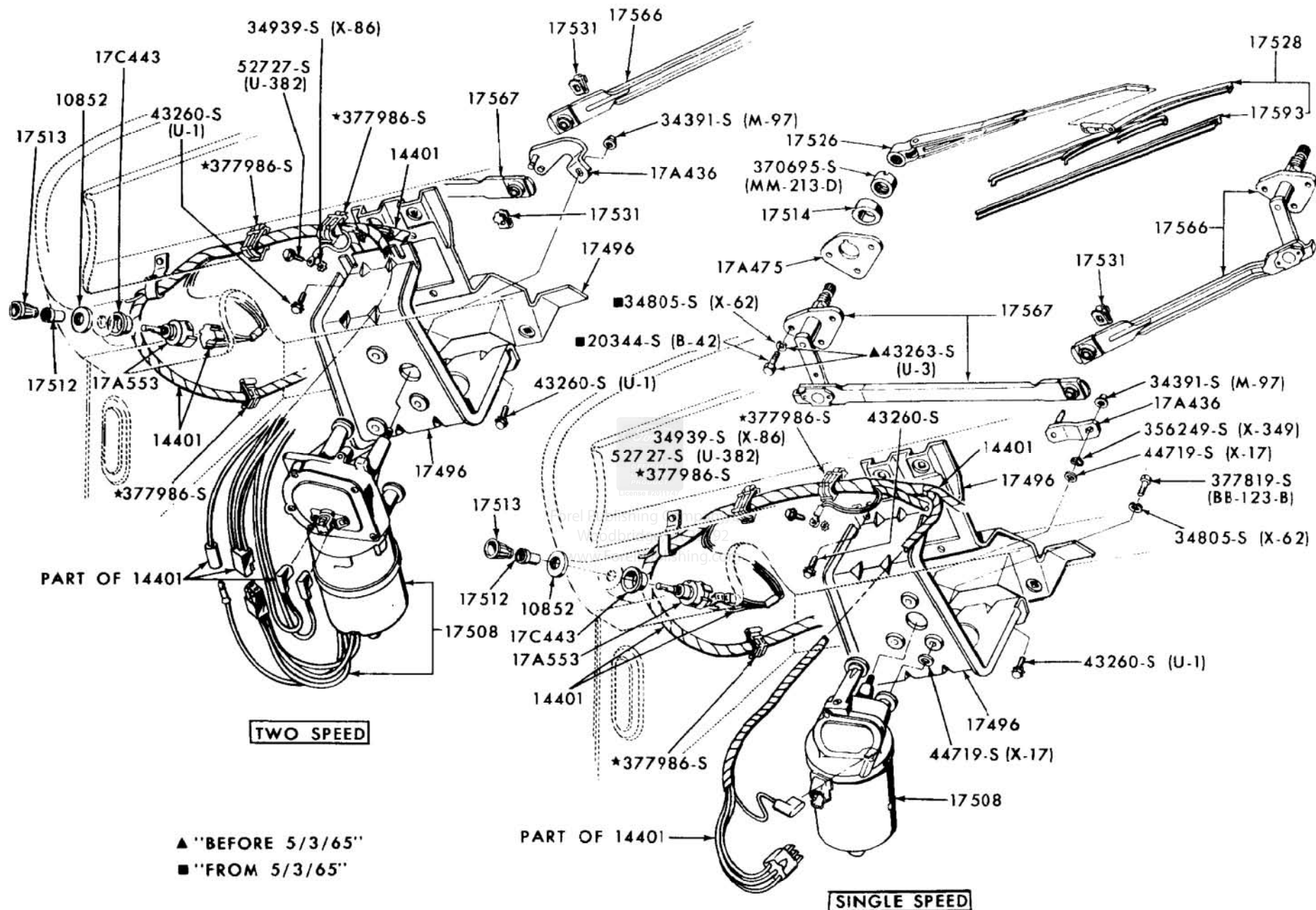

WINDSHIELD WIPER
 1965 / 68 MUSTANG

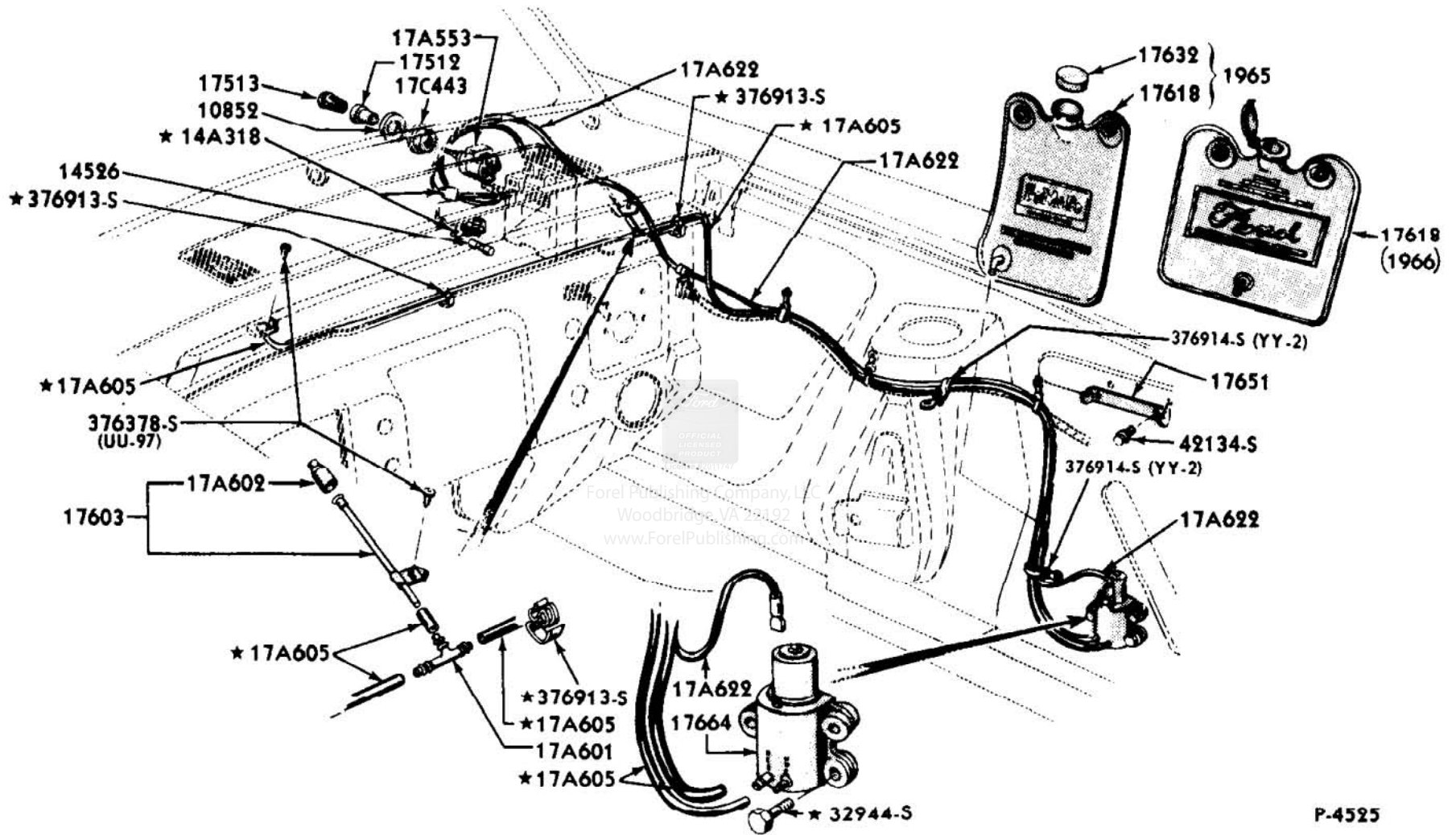

WINDSHIELD WASHER
1965 / 66 MUSTANG

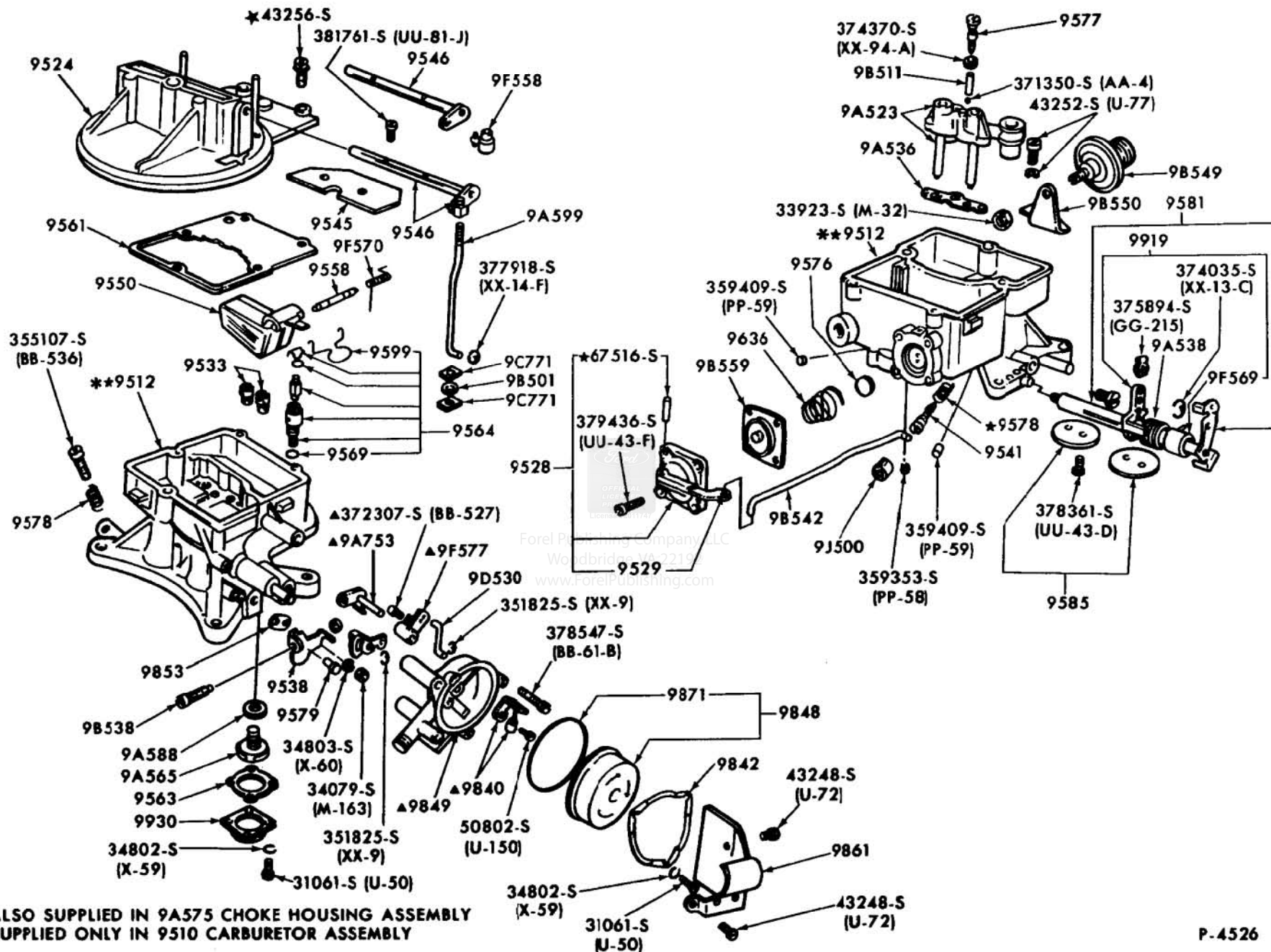

CARBURETOR - FORD 2V (WITH PISTON TYPE CHOKE AND ACCELERATOR PUMP CHECK VALVE)
1965 / 69 (8 CYLINDER 260, 289, 302, 351, 390, 429 ENGINES)

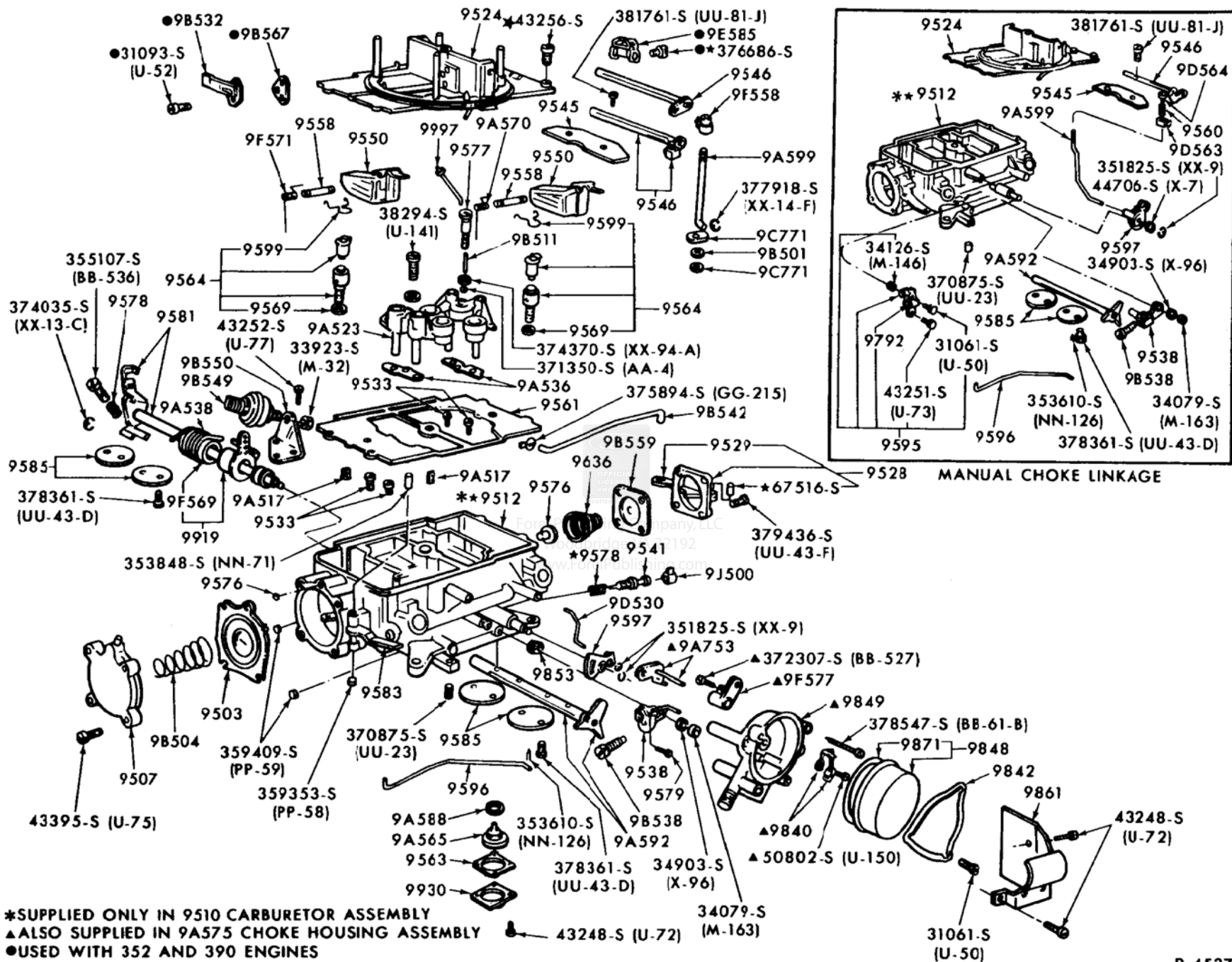

CARBURETOR - 4V (WITH PISTON TYPE CHOKE AND ACCELERATOR PUMP CHECK VALVE)
1965 / 69 (8 CYLINDER 289, 302, 352, 390, 428 ENGINES)

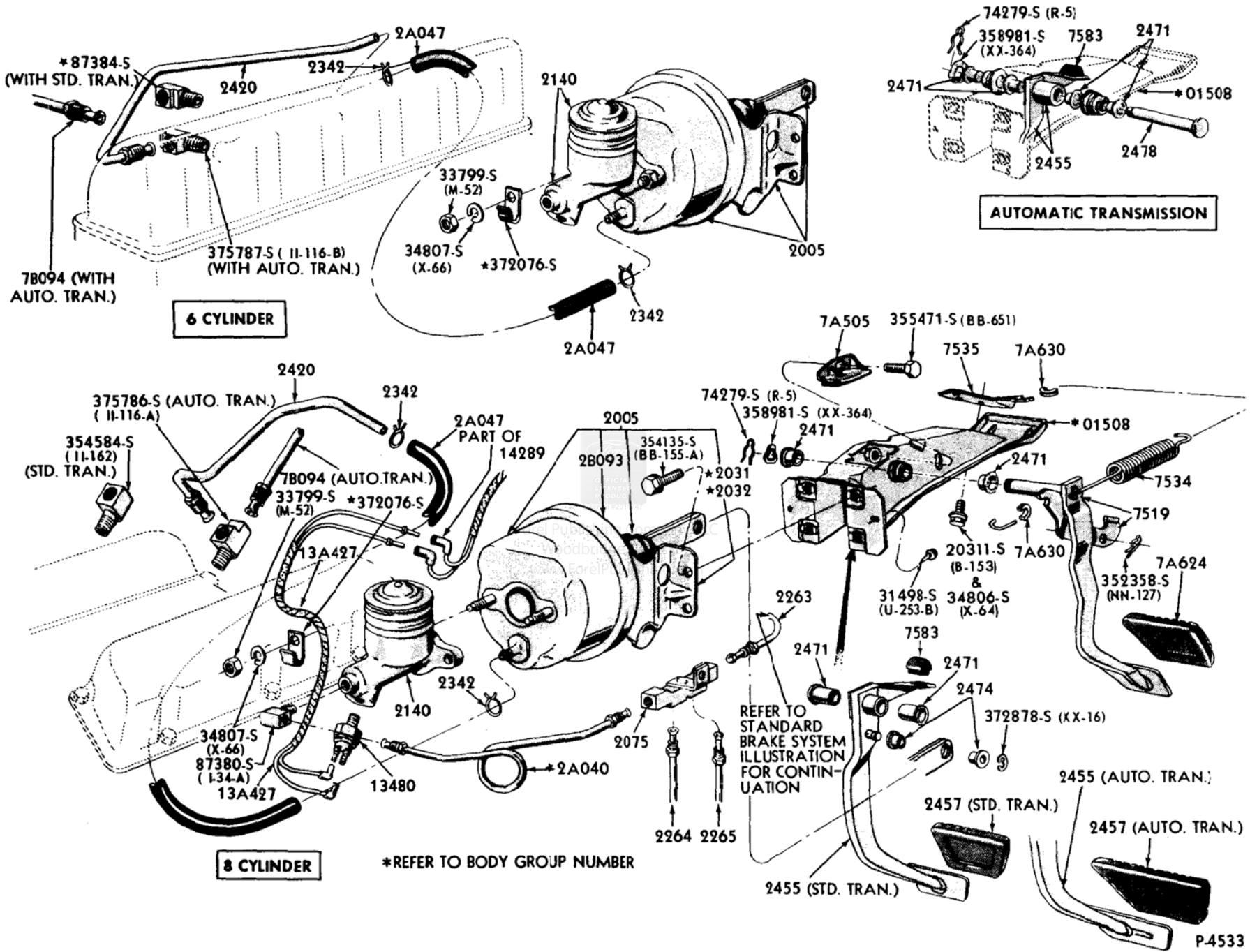

POWER BRAKE BOOSTER INSTALLATION (BENDIX)
1965 / 66 MUSTANG

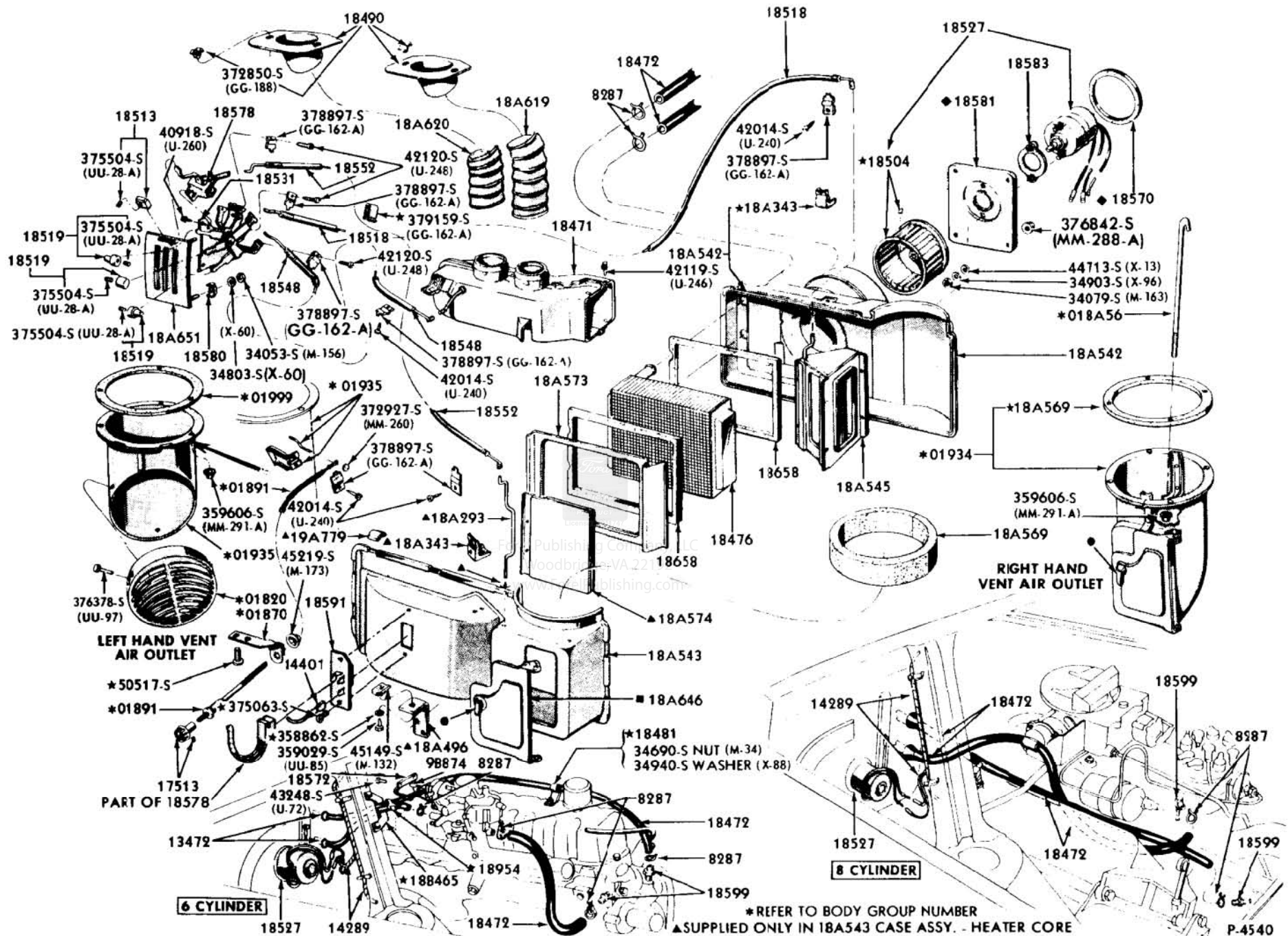

FRESH AIR HEATER AND RELATED PARTS
1965 / 66 MUSTANG

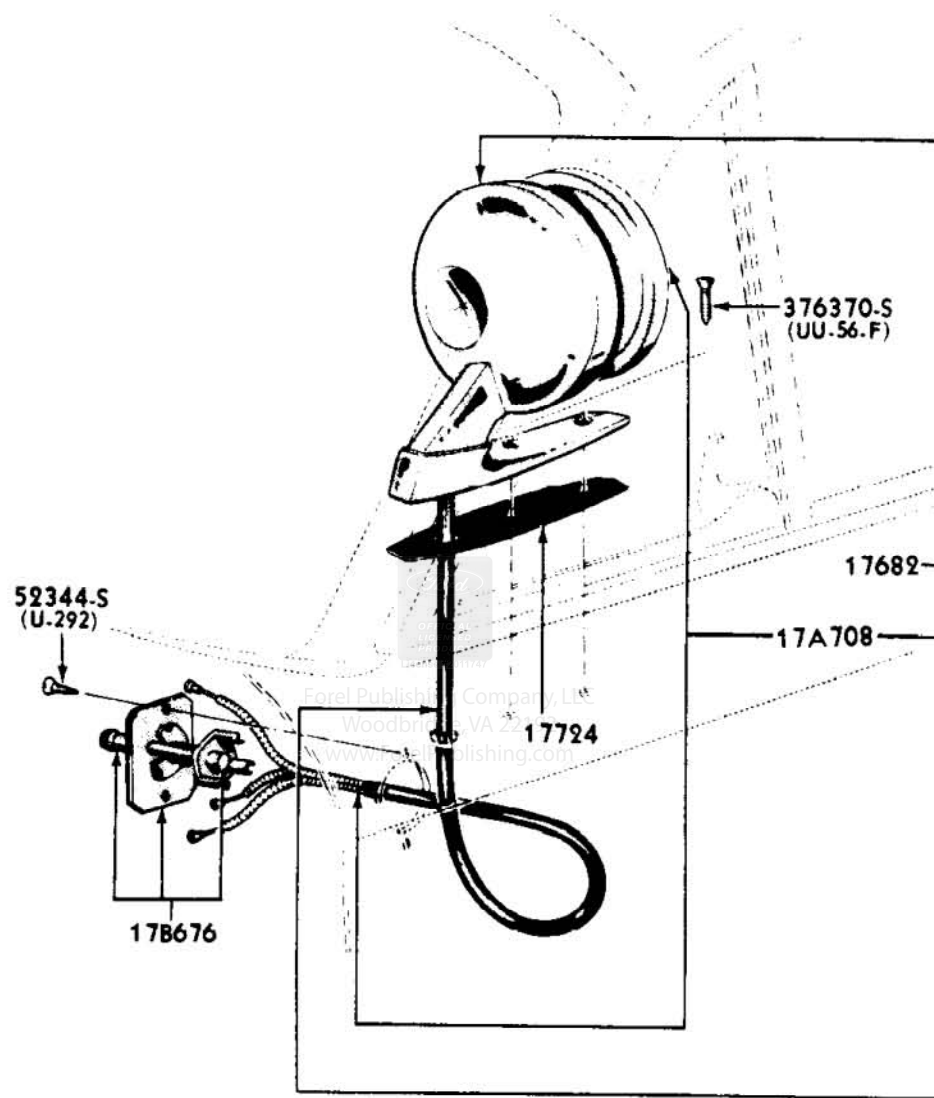

P-4543

MIRROR - REMOTE CONTROL
1965 / 66 FAIRLANE, FALCON, AND MUSTANG

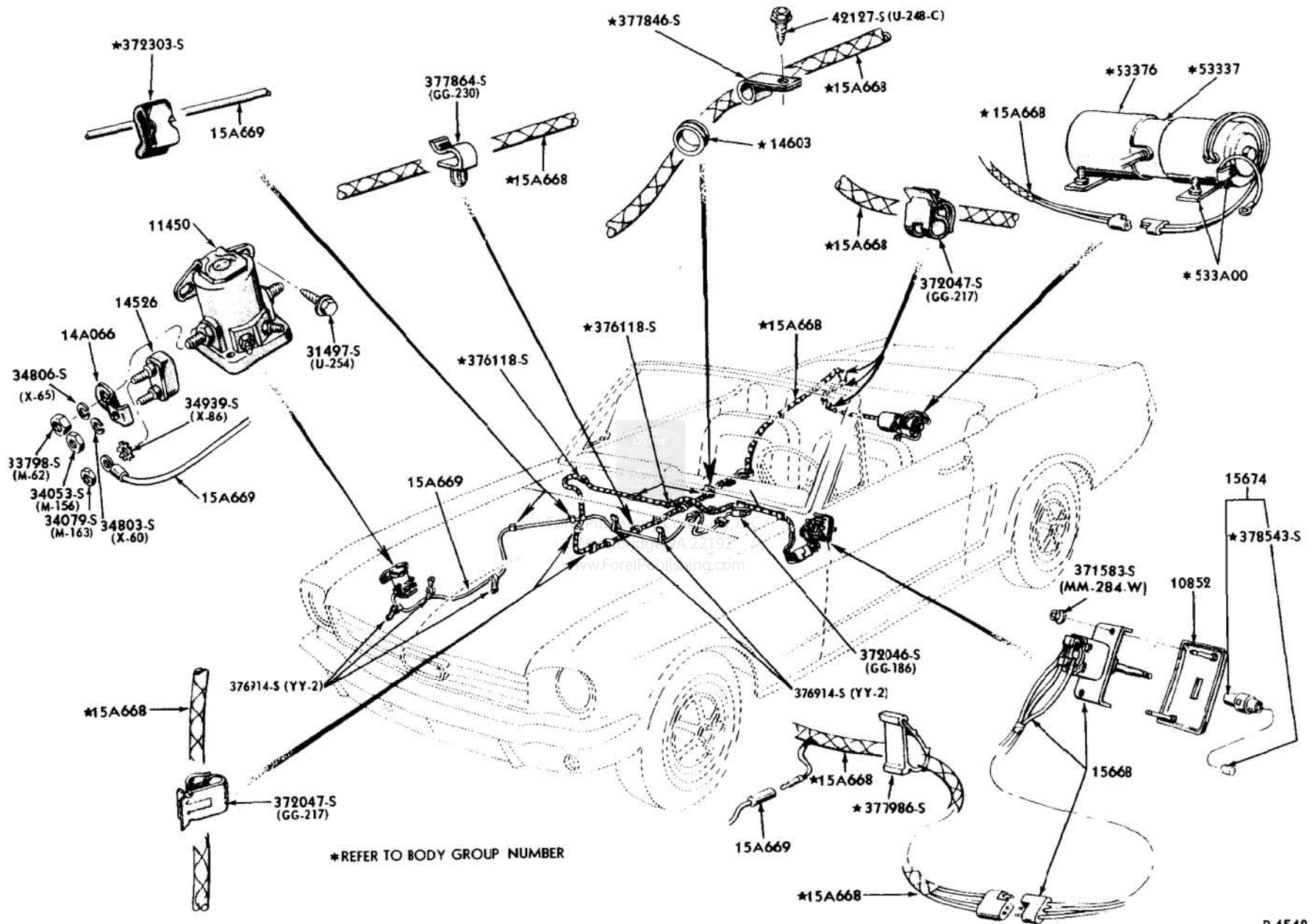

CONVERTIBLE TOP ELECTRICAL SYSTEM
1965 / 66 MUSTANG

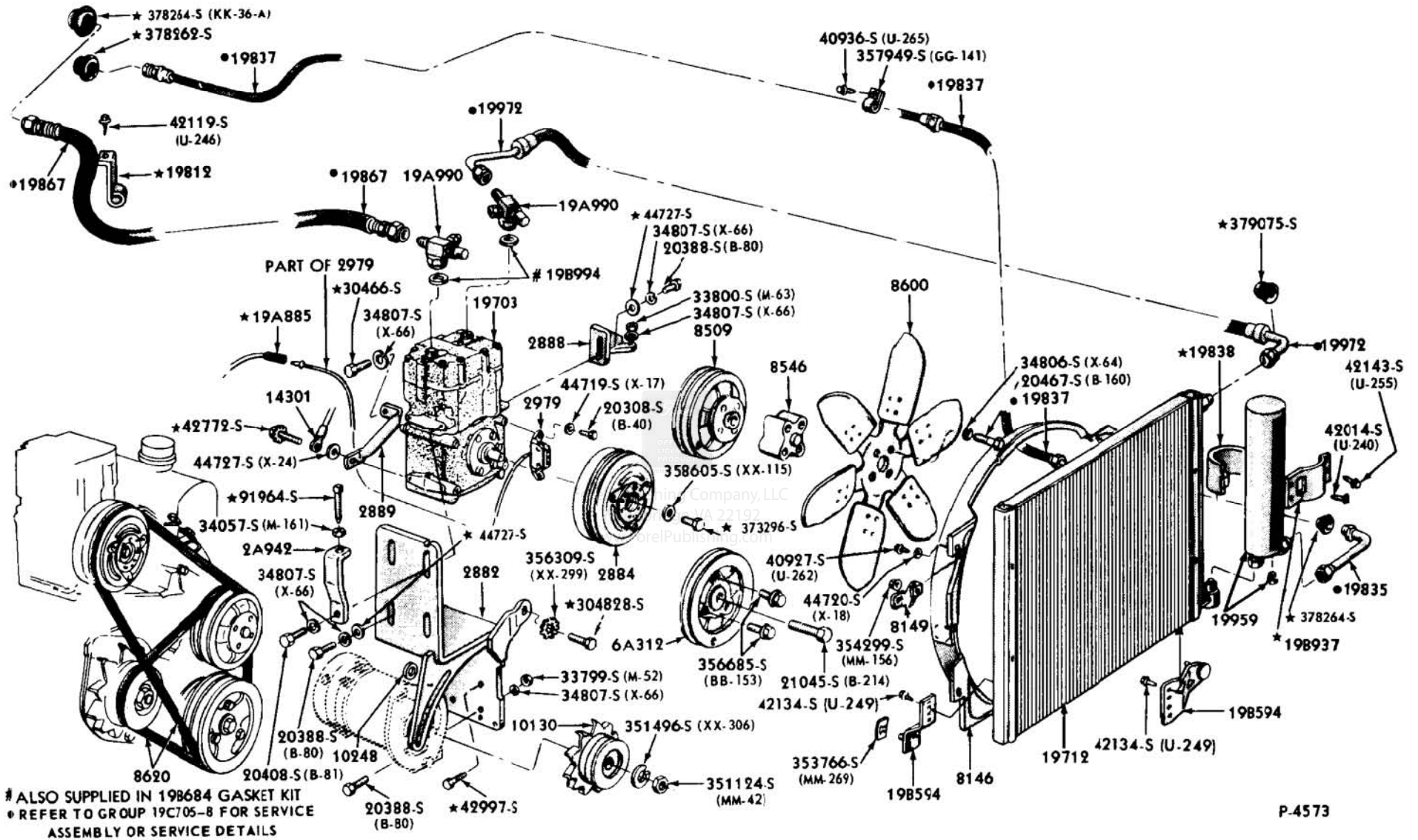

AIR CONDITIONING PARTS (ENGINE COMPARTMENT)
1965 / 66 - MUSTANG - 6 CYL - W/HANG-ON A/C

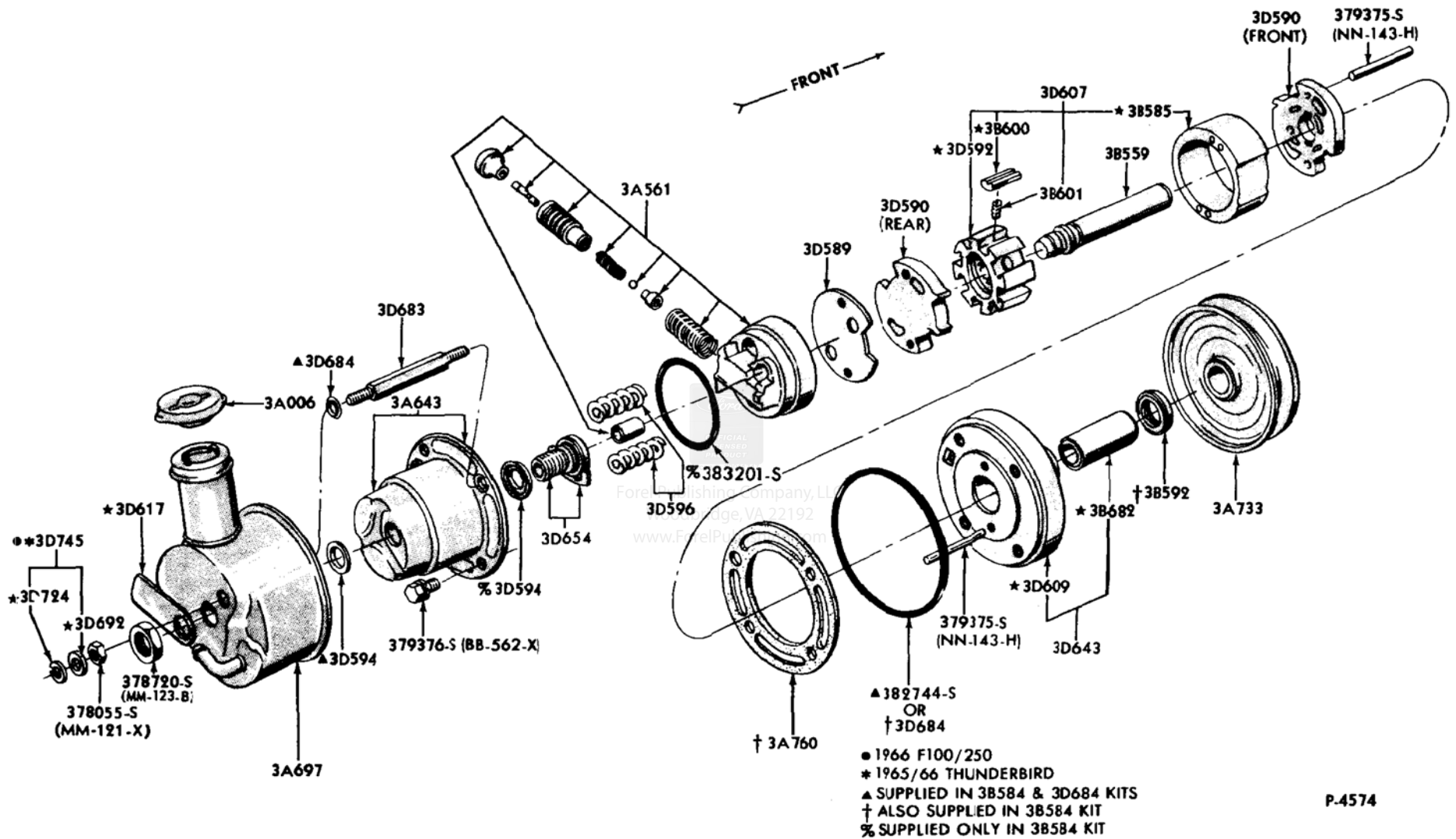

**POWER STEERING PUMP DETAILS (FORD SLIPPER TYPE)
1965/66 FORD, FAIRLANE, FALCON, & THUNDERBIRD, 1965 /66 MUSTANG**

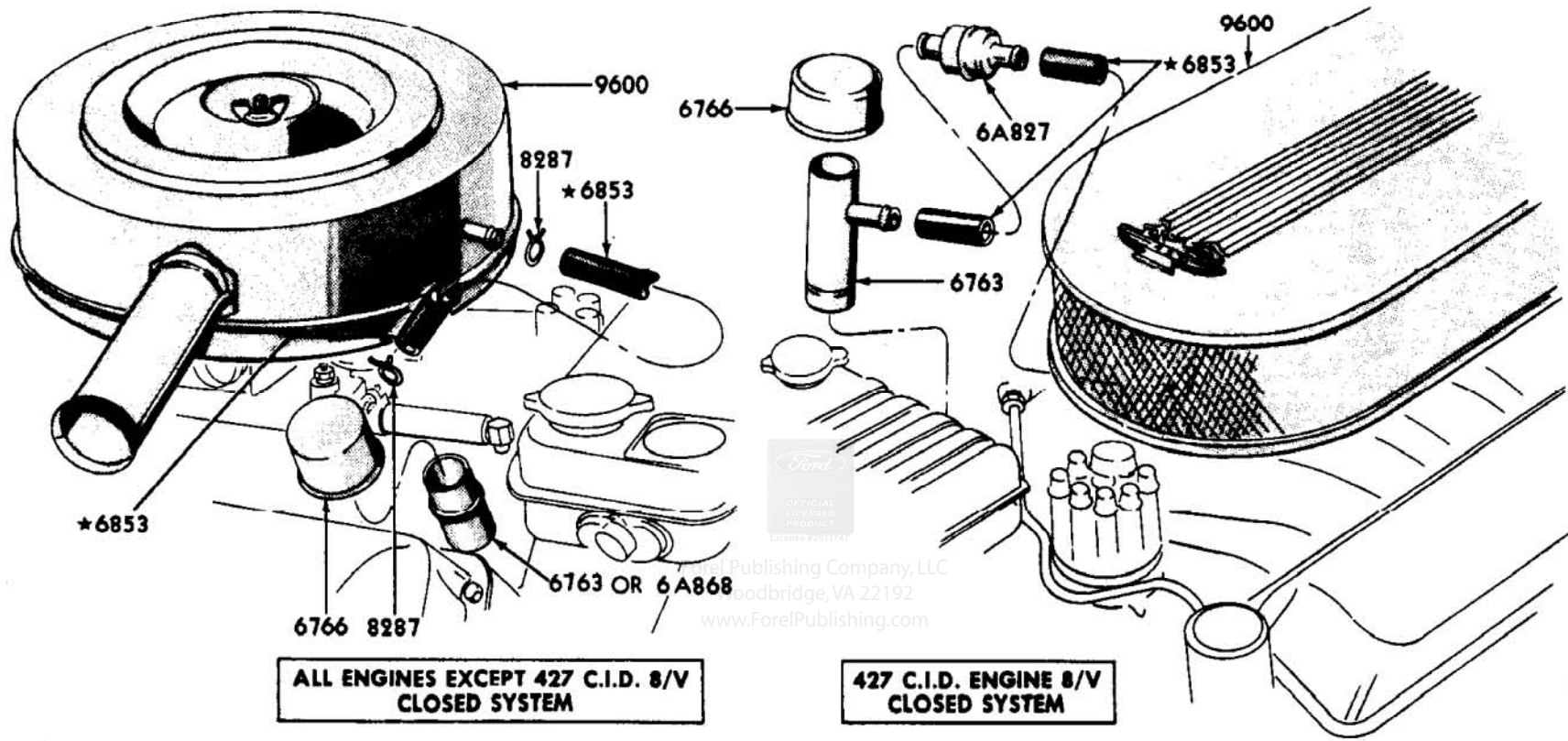

**ALL ENGINES EXCEPT 427 C.I.D. 8/V
CLOSED SYSTEM**

**427 C.I.D. ENGINE 8/V
CLOSED SYSTEM**

**NOTE - ONLY AIR CLEANER OIL BREATHER CAP PORTION SHOWN.
REFER TO PAGES 1 THRU 4 SECTION 66.1 FOR BALANCE OF EMISSION CONTROL SYSTEM**

P-4575

**ENGINE EMISSION REDUCTION - AIR CLEANER OIL BREATHER CAP AND RELATED PARTS - CLOSED SYSTEM
1965/69 6 CYLINDER 170, 200, 240 AND 8 CYLINDER 260, 289, 302, 352, 390, 427, 428**

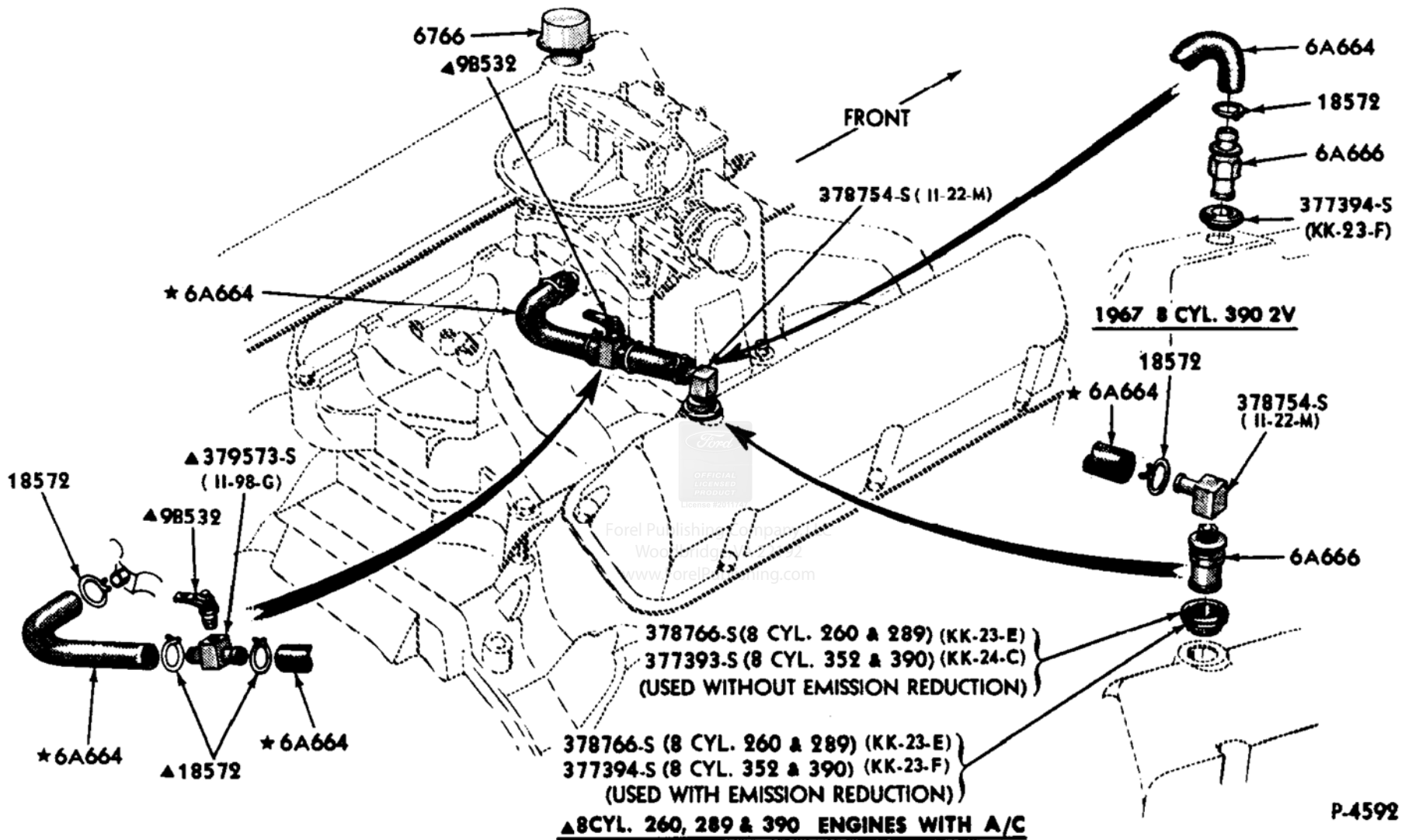

ENGINE EMISSION REDUCTION, HOT IDLE COMPENSATOR AND RELATED PARTS - ROCKER ARM COVER TYPE
 1965/70 8 CYLINDER 260, 289, 302, AND 352 1965 8 CYLINDER 390
 1967/70 8 CYLINDER 390 - 2/B CARBURETOR

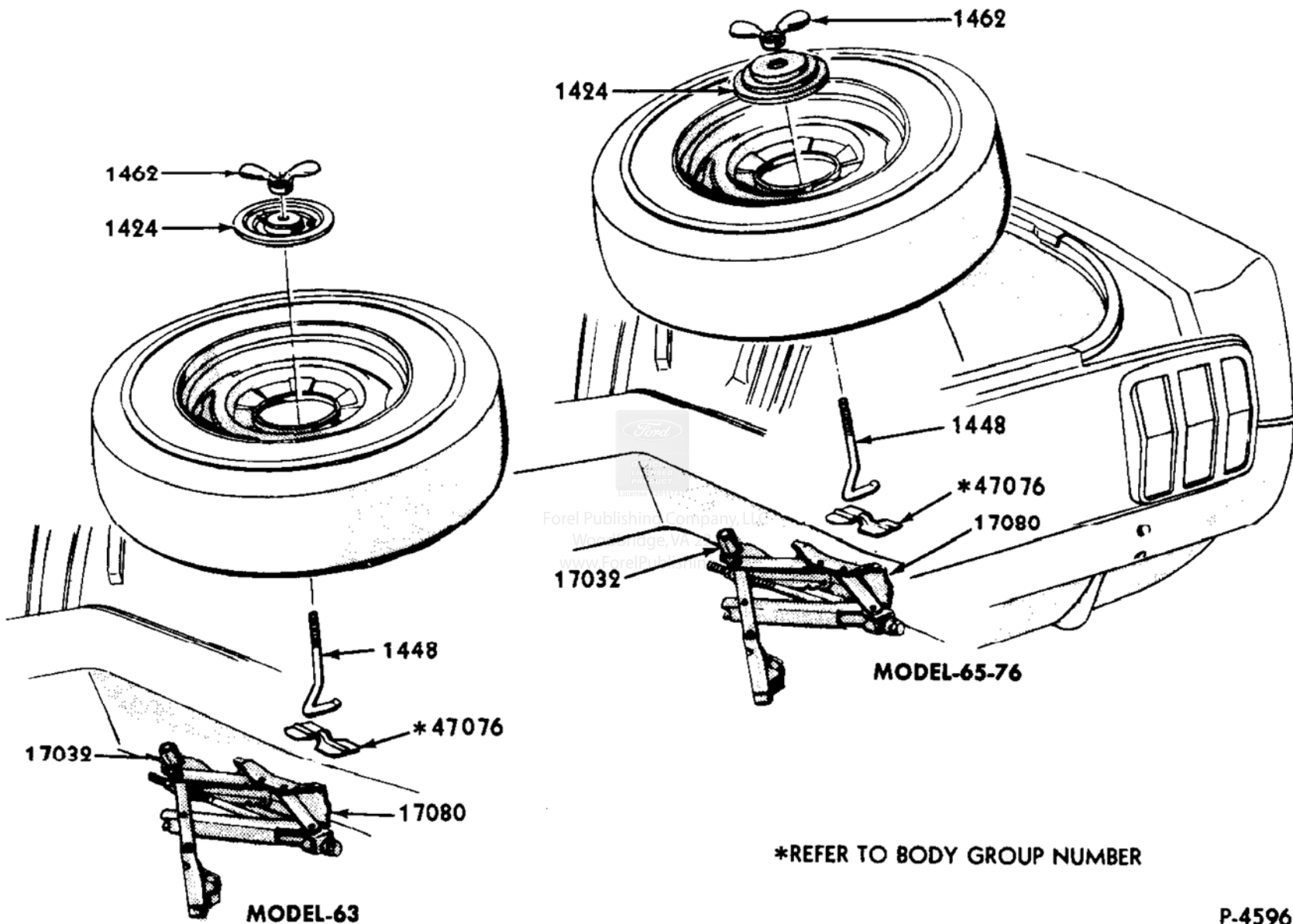

JACK and SPARE WHEEL PARTS
1965/67 MUSTANG

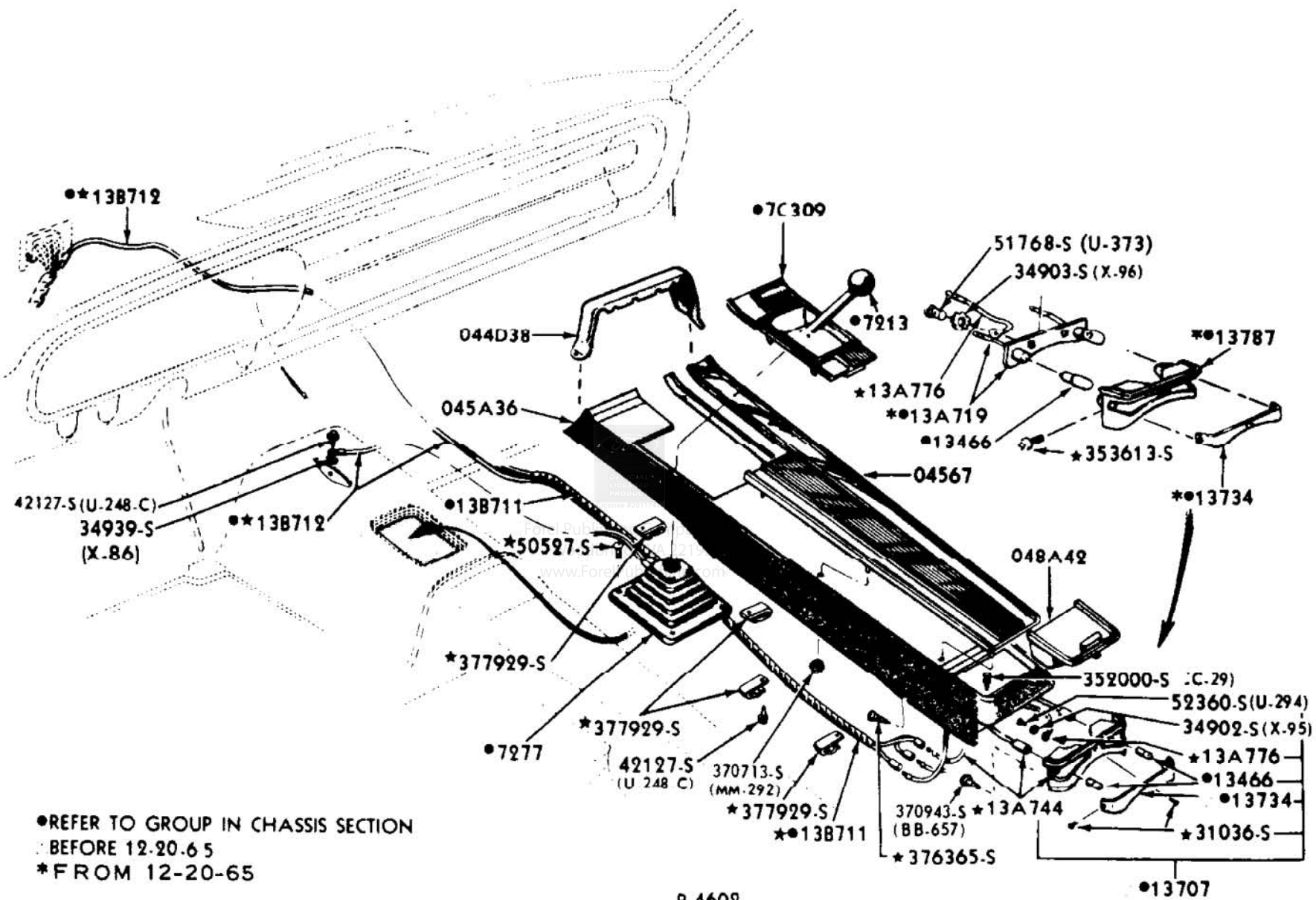

CONSOLE AND RELATED PARTS
 1965 / 66 MUSTANG (WITH A/C)

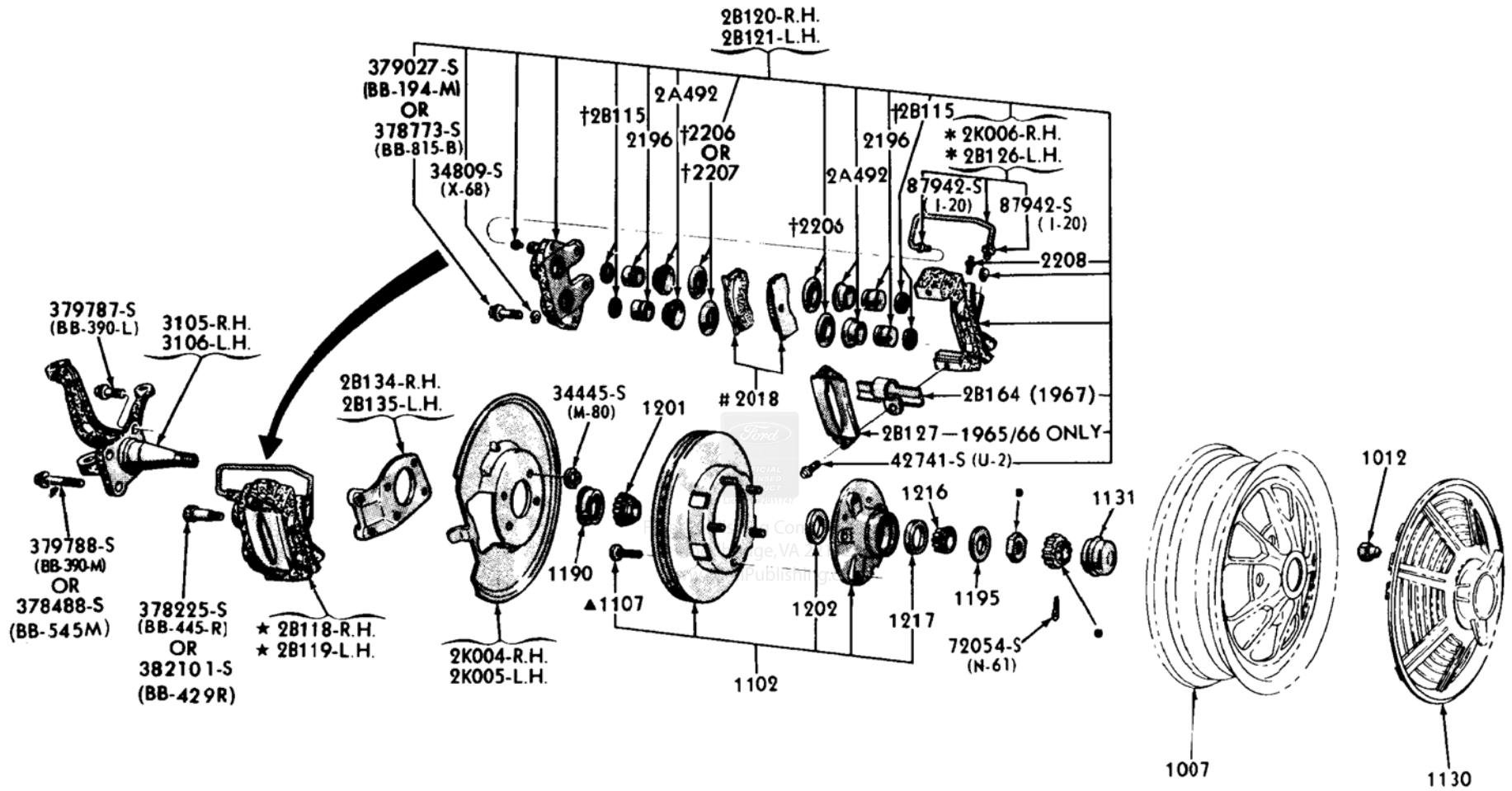

* (CUT FROM BULK TUBING)
 ▲ IF MORE THAN ONE BOLT HAS TO BE REPLACED IN AN ASSEMBLY-
 COMPLETE HUB AND DRUM MUST BE REPLACED
 † ALSO SERVICED IN 2221 KIT
 ● REFER TO GROUP 1102 FOR PART NUMBER & MODEL APPLICATION
 # SERVICED IN 2001 KIT

10-70

P-4604

FRONT DISC BRAKE DETAILS
1965 / 67 MUSTANG 1967 FAIRLANE / TORINO

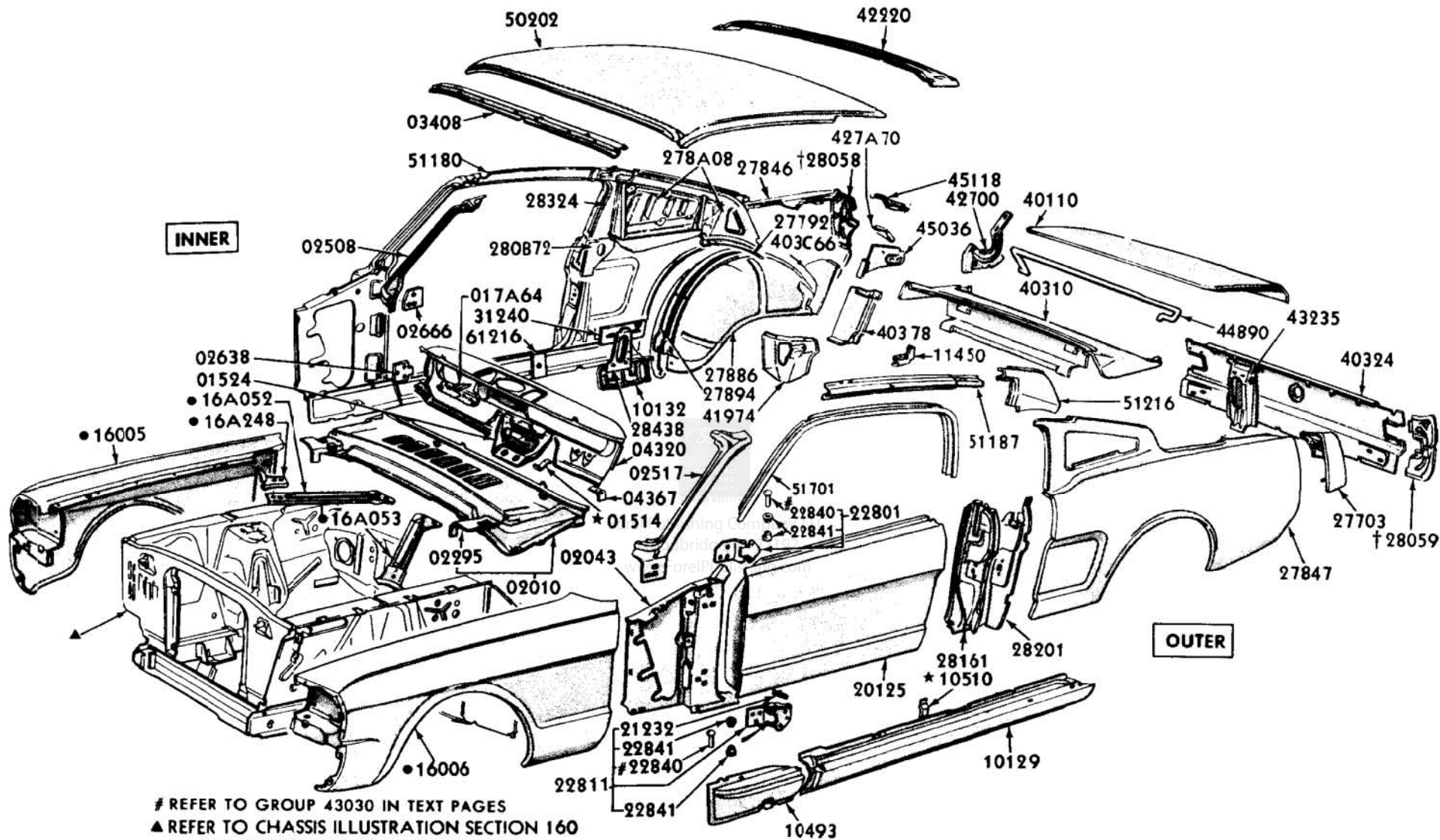

REFER TO GROUP 43030 IN TEXT PAGES
 ▲ REFER TO CHASSIS ILLUSTRATION SECTION 160 FOR EXPLODED VIEW INFORMATION
 ● REFER TO CHASSIS GROUP
 † ALSO INCLUDED IN 27846-7

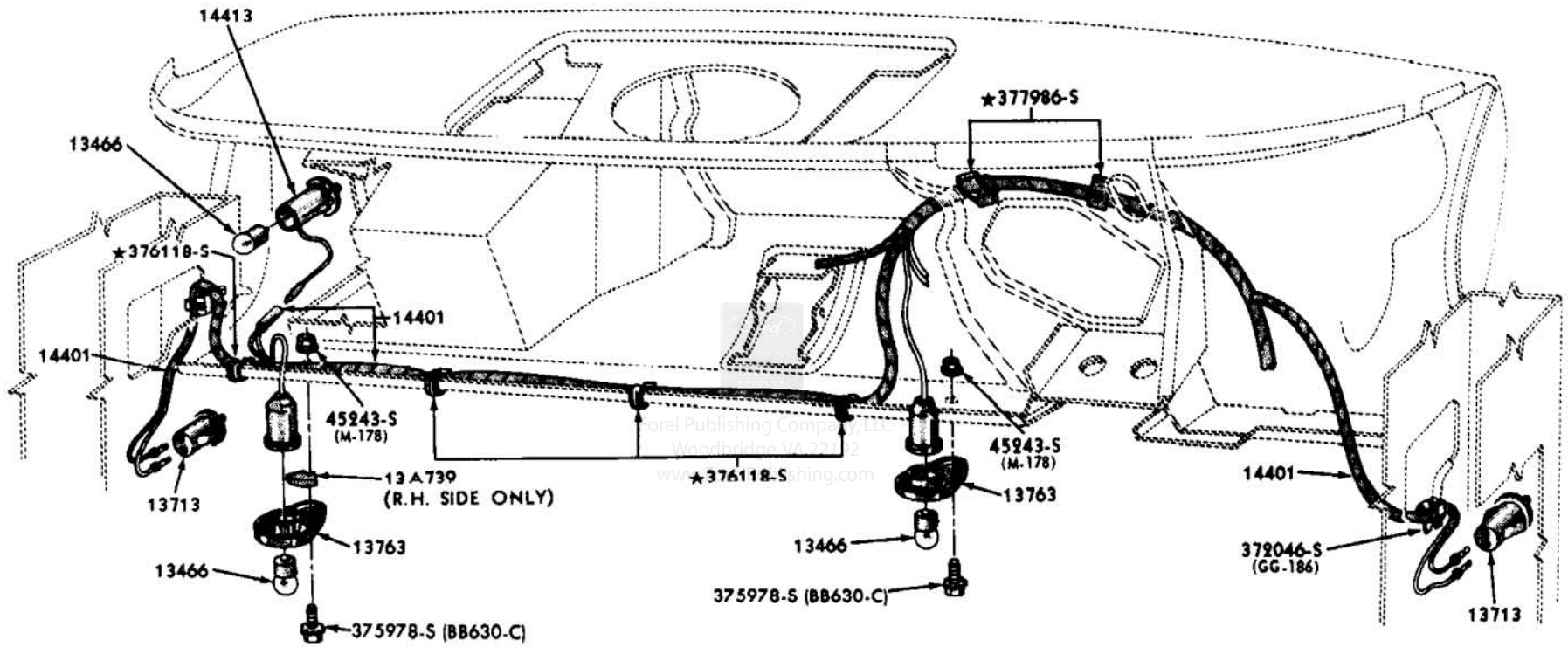

P-4734

**COURTESY LAMP AND WIRING - INSTRUMENT PANEL MOUNTED
1965 / 68 MUSTANG**

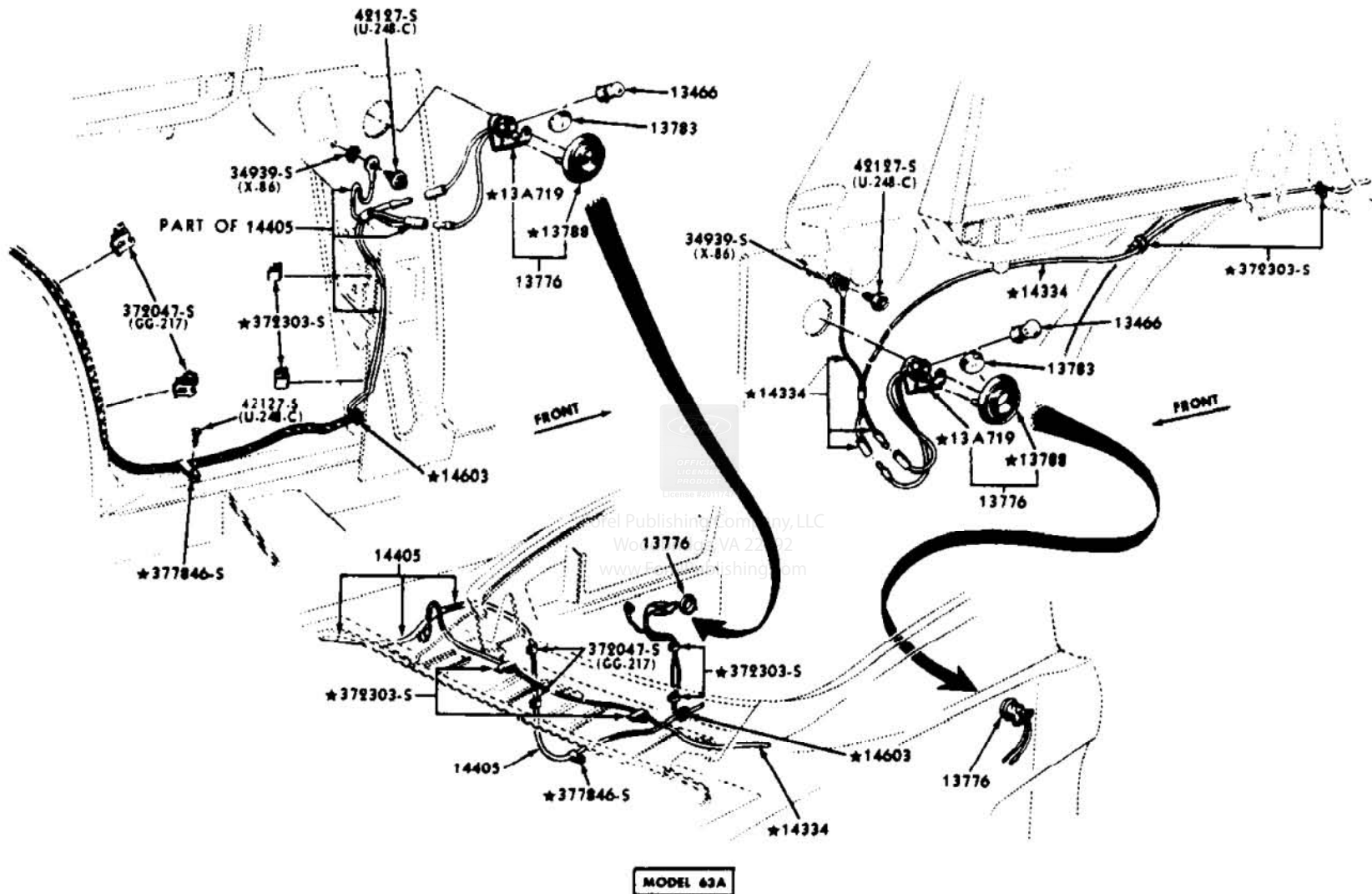

P4735

COURTESY LAMP AND WIRING - INTERIOR QUARTER PANEL
1965 / 70 MUSTANG - "FASTBACK"

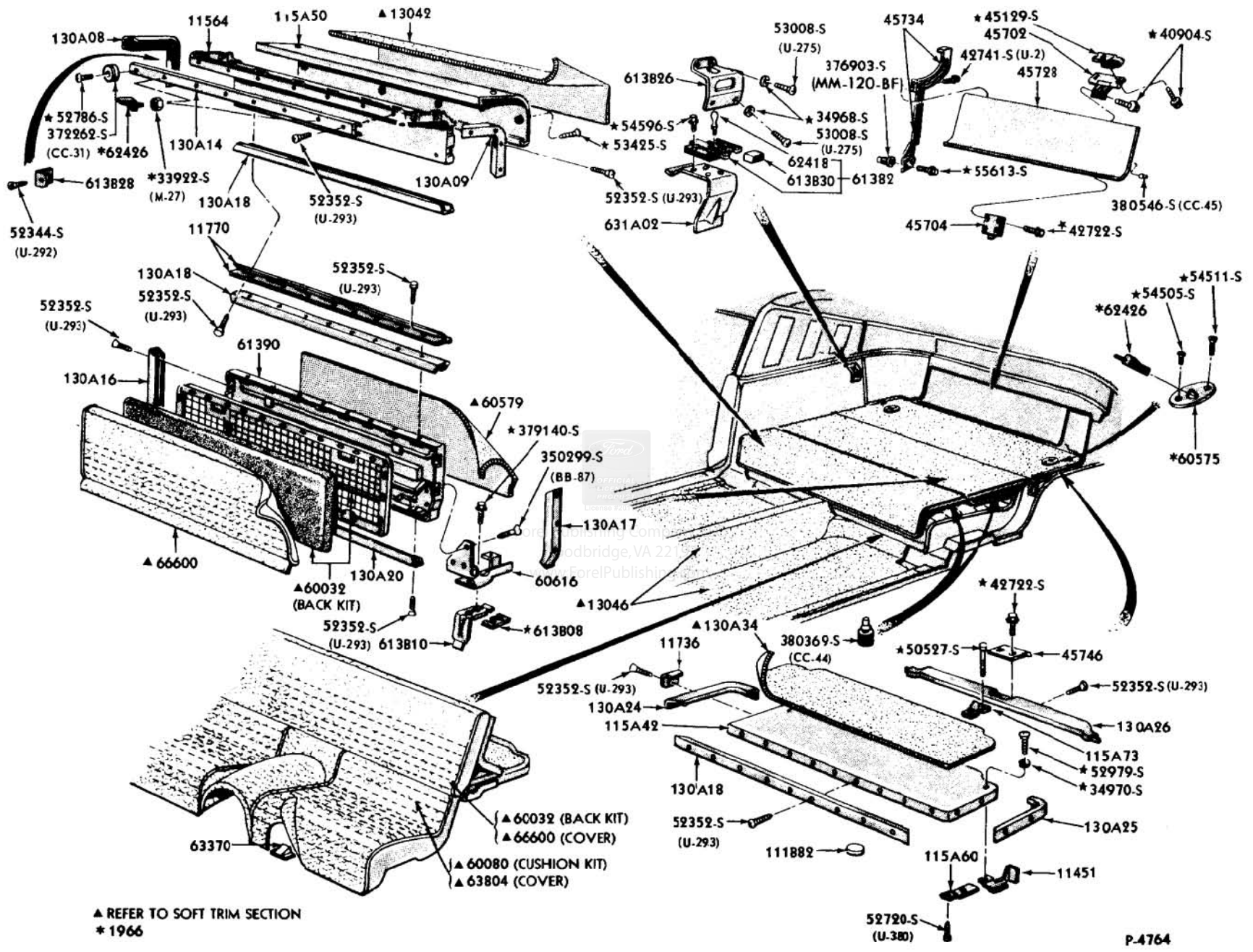

REAR SEAT AND RELATED PARTS - FOLDING
 1965 / 66 MUSTANG BODY TYPE 63

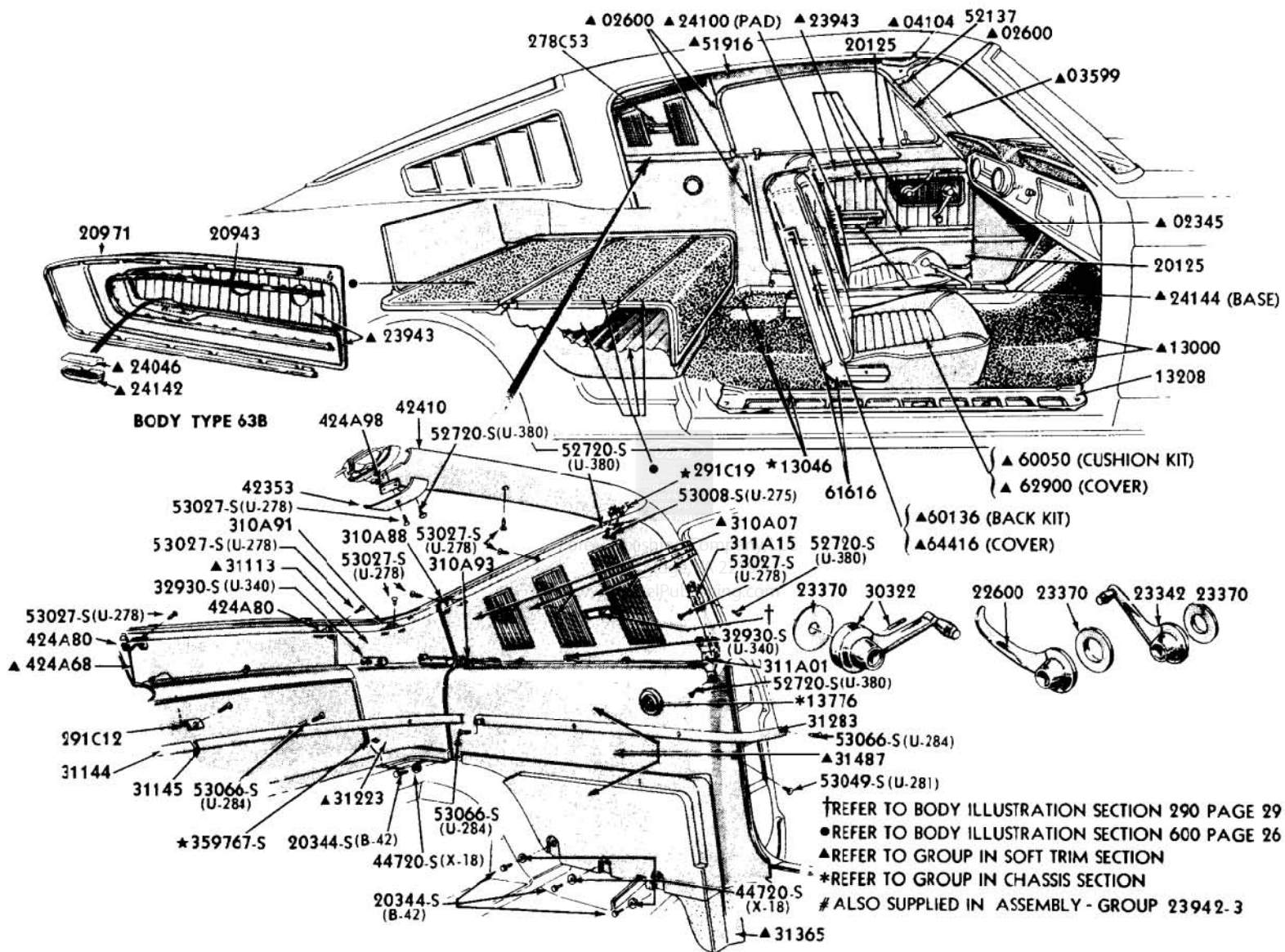

INTERIOR TRIM AND RELATED PARTS - TYPICAL
1965 / 66 - MUSTANG - BODY TYPE 63

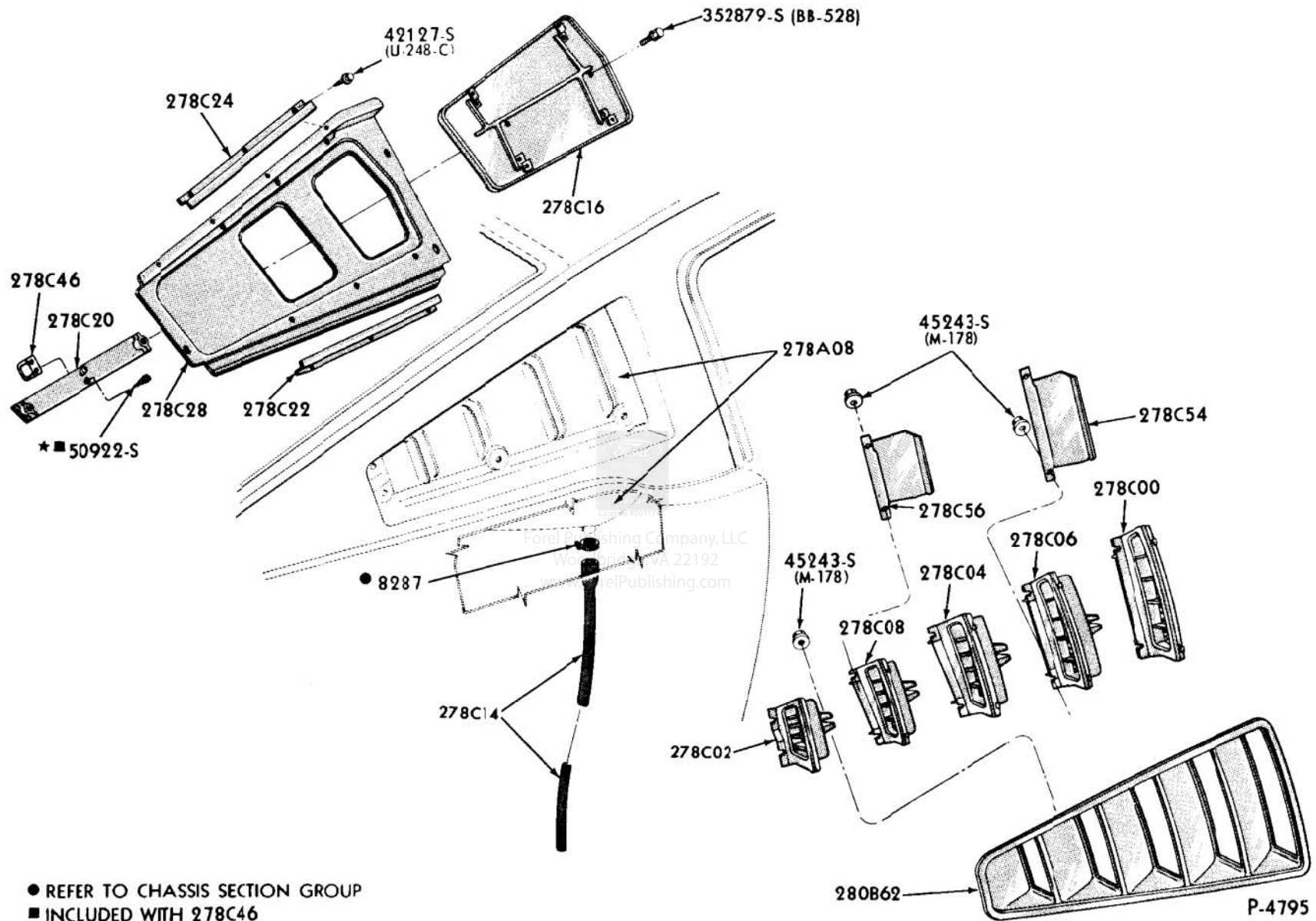

**QUARTER AIR EXTRACTOR AND RELATED PARTS
1965 / 66 MUSTANG - BODY TYPE 63**

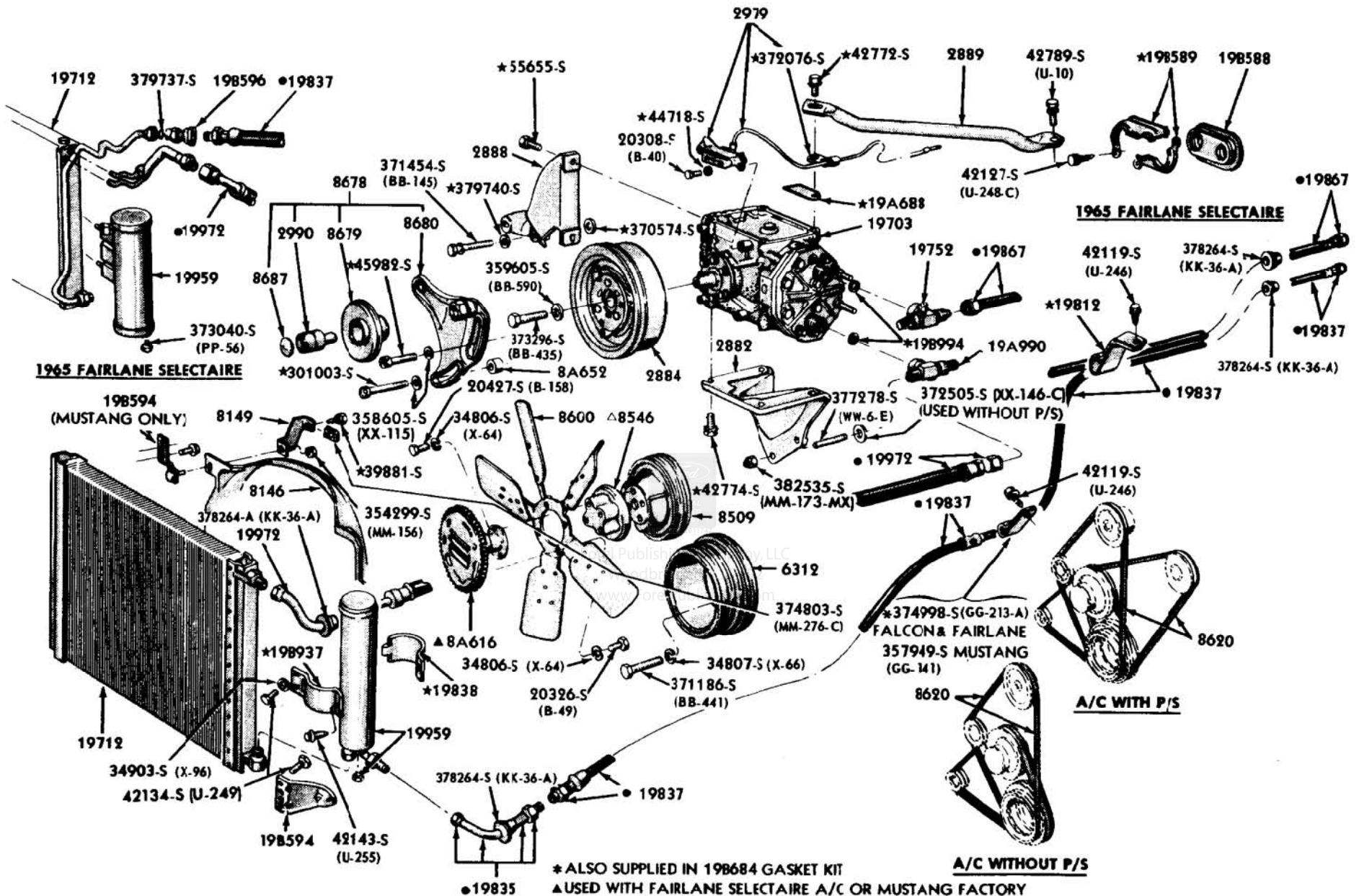

1965 FAIRLANE SELECTAIRE

1965 FAIRLANE SELECTAIRE

198594 (MUSTANG ONLY)

A/C WITH P/S

A/C WITHOUT P/S

- * ALSO SUPPLIED IN 198684 GASKET KIT
- ▲ USED WITH FAIRLANE SELECTAIRE A/C OR MUSTANG FACTORY INSTALLED FORDAIRE A/C
- △ USED WITH FAIRLANE & FALCON WITH FORDAIRE A/C OR MUSTANG WITH DEALER INSTALLED FORDAIRE A/C
- REFER TO GROUP 19C705-8 FOR SERVICE ASSEMBLY OR SERVICE DETAILS

AIR CONDITIONING PARTS (ENGINE COMPARTMENT)
 1965 FAIRLANE AND FALCON AND 1965/66 MUSTANG (W/ ALTERNATOR) - 8 CYL.

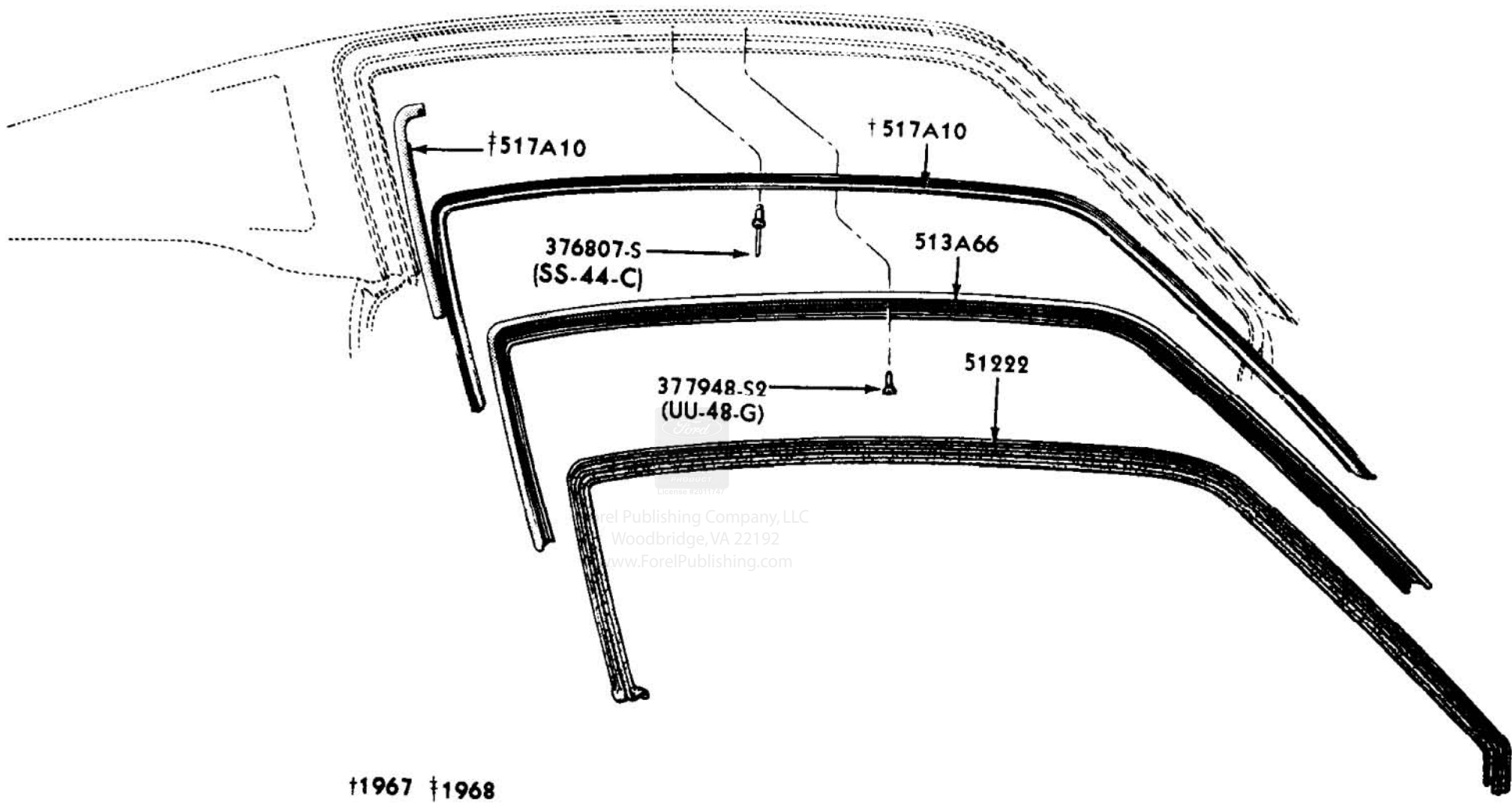

P-4838

**ROOF SIDE MOULDINGS AND WEATHERSTRIPS
1965 / 66 MUSTANG - BODY TYPE 63 - TYPICAL**

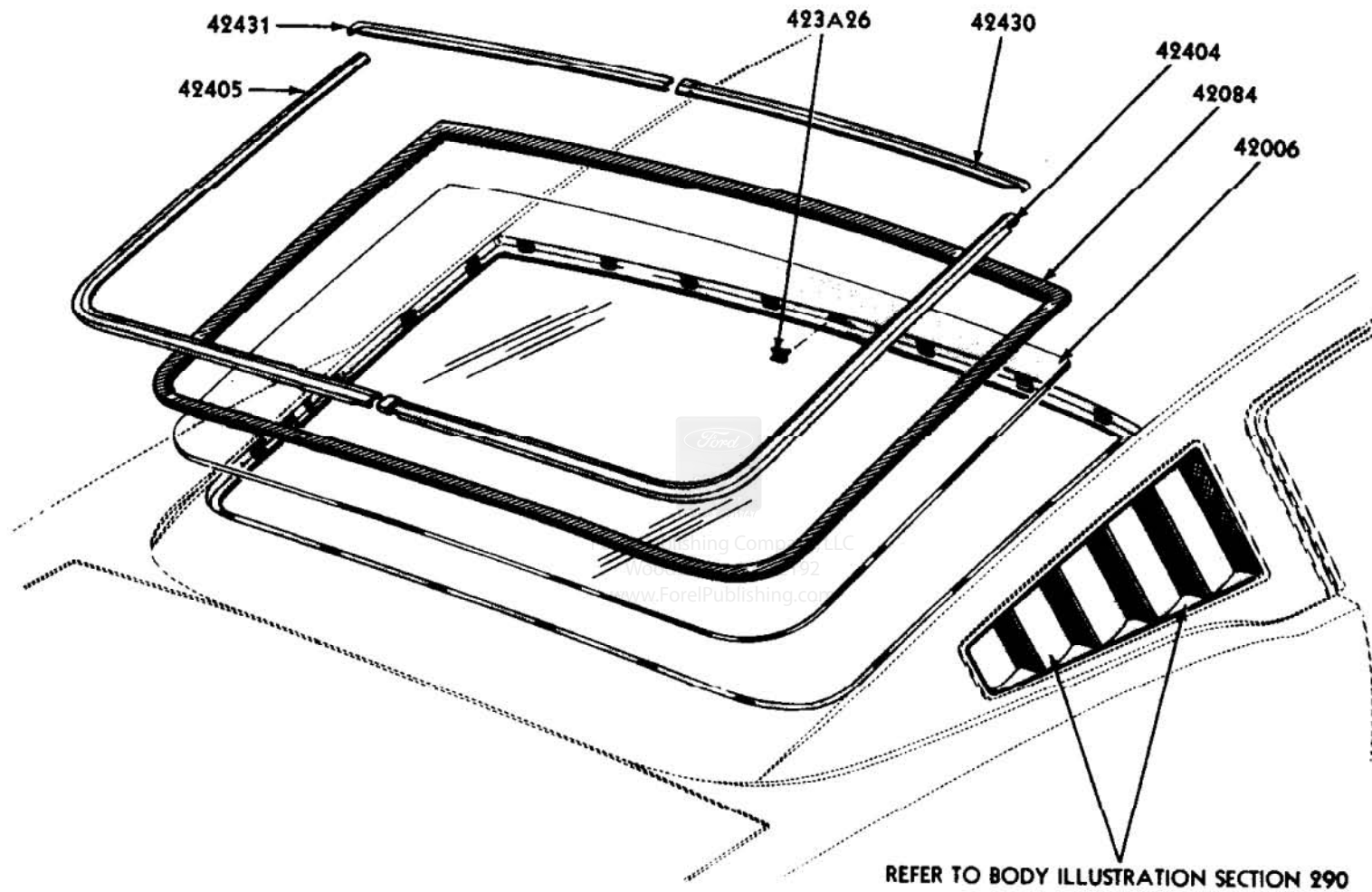

P-4839

**BACK WINDOW AND RELATED PARTS
1965 / 66 MUSTANG - BODY TYPE 63**

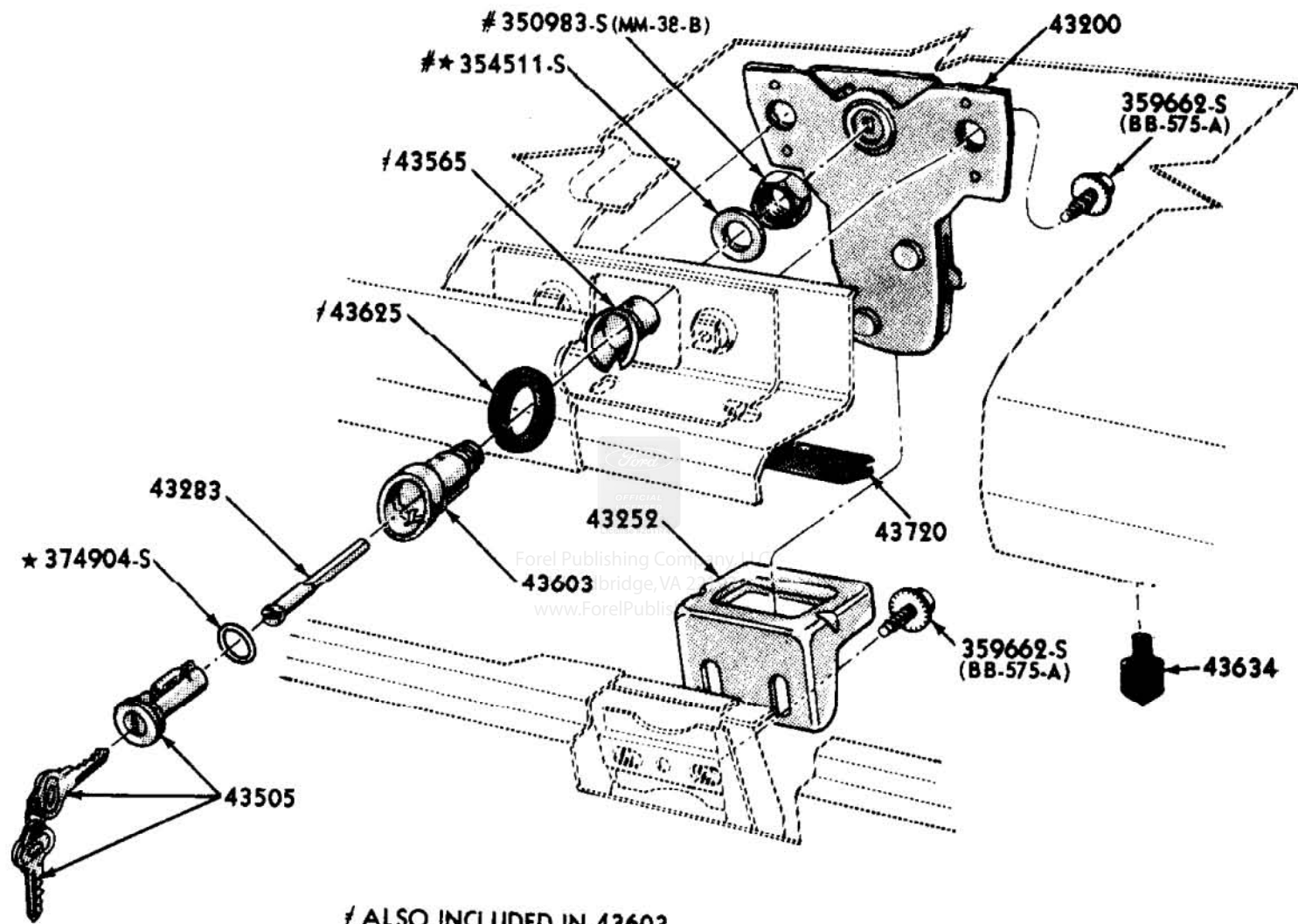

/ ALSO INCLUDED IN 43603
 # INCLUDED IN 43603

P-4844

LUGGAGE COMPARTMENT DOOR LATCH AND RELATED PARTS
1965 / 66 MUSTANG - BODY TYPE 63



Forel Publishing Company, LLC
 Woodbridge, VA 22192
 www.ForelPublishing.com

BUSHINGS - AUTOMATIC TRANSMISSION MISCELLANEOUS

A	B	C	PART NUMBER	A	B	C	PART NUMBER
3/4"	1 1/2"	1 3/8"	⊕ B1A 7025-A	1"	1 3/4"	1 5/8"	★COMP 7B256-A
3/4"	1 1/2"	1 3/8"	⊕ B1A 7025-B	3/4"	1 1/8"	1"	B1AZ 7B257-B
7/8"	1 1/2"	1 5/8"	B5A 7025-A	1"	1 1/8"	1"	B5AZ 7B257-A
7/8"	1 5/8"	1 1/2"	COMP 7025-A	29/32"	2 1/2"	2 3/8"	C0AP 7B257-A
1 1/2"	1 5/8"	1 1/2"	B3TZ 7A034-A	15/16"	1 1/4"	1 1/8"	★COMP 7B257-A
2 1/8"	1 13/16"	1 11/16"	B5AZ 7A034-A	33/64"	2 1/8"	2"	C0AP 7B258-A
1 3/8"	1 1/2"	1 3/8"	C0DP 7A034-B	37/64"	2 1/16"	1 15/16"	C1AZ 7B258-A
3/4"	1"	7/8"	B1AZ 7120-A	7/16"	1 15/16"	1 13/16"	COMP 7B259-A
27/32"	1"	7/8"	★B5A 7120-B	3/8"	1 15/16"	1 13/16"	C1AZ 7B259-A
27/32"	1 1/8"	1"	★COMP 7120-A	3/4"	2 3/16"	2 1/16"	B5AZ 7B260-A
27/32"	1"	7/8"	C3AZ 7120-B	7/8"	2"	1 7/8"	C0AP 7B260-A
5/8"	3 3/8"	3 3/16"	B1AZ 7A132-A	13/16"	2 5/16"	2 3/16"	★C3SZ 7B260-B
11/16"	3 5/16"	3 5/32"	B9AP 7A132-A	3/4"	1 1/32"	29/32"	★B1AZ 7B261-A
23/32"	3 27/32"	3 11/16"	B9MP 7A132-A	9/16"	1"	15/16"	B5AZ 7B261-A
11/16"	3 5/16"	3 5/32"	★C3AZ 7A132-A	1"	1 3/16"	1 3/64"	C0AP 7B261-A
11/16"	3 5/16"	3 5/32"	★C4AZ 7A132-A	9/16"	1 1/16"	1"	★COMP 7B261-A
7/8"	1 5/8"	1 1/2"	B5AZ 7B256-A	1 1/16"	1 7/16"	1 5/16"	B5AZ 7B262-A
3/8"	1 1/8"	1"	★C0AP 7B256-A	1 1/8"	1 11/16"	1 9/16"	COMP 7B262-A

⊕ RECONDITIONERS ONLY ⊕ DEALER INSTALLATION

BUSHINGS - AUTOMATIC TRANSMISSION MISCELLANEOUS

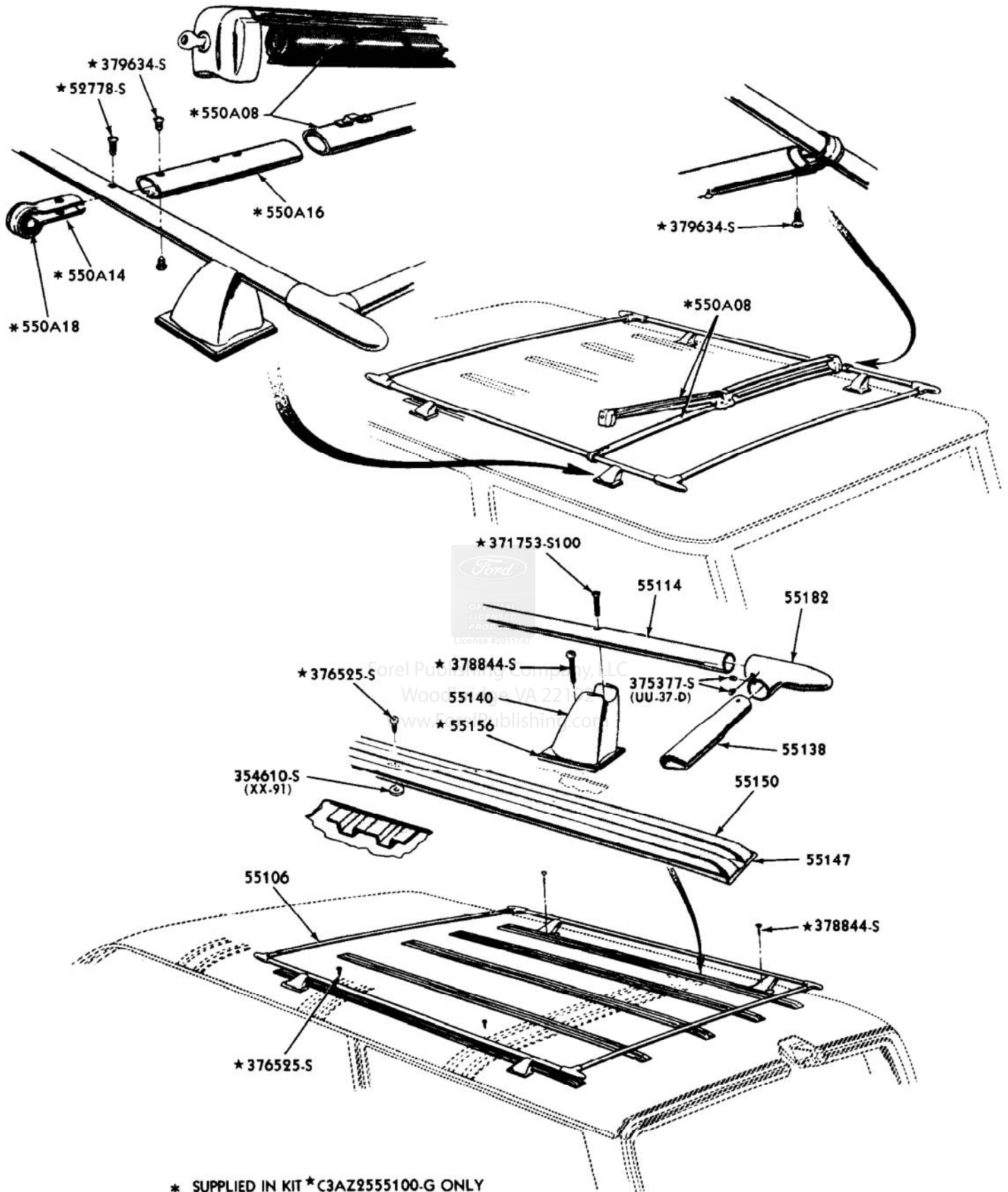

P-4863

**LUGGAGE AND CARRIER AND RELATED PARTS - NON-ADJUSTABLE ROOF MOUNTED (5 SLATS)
 1965 / 66 FORD, FAIRLANE, FALCON, MUSTANG, AND THUNDERBIRD - TYPICAL**

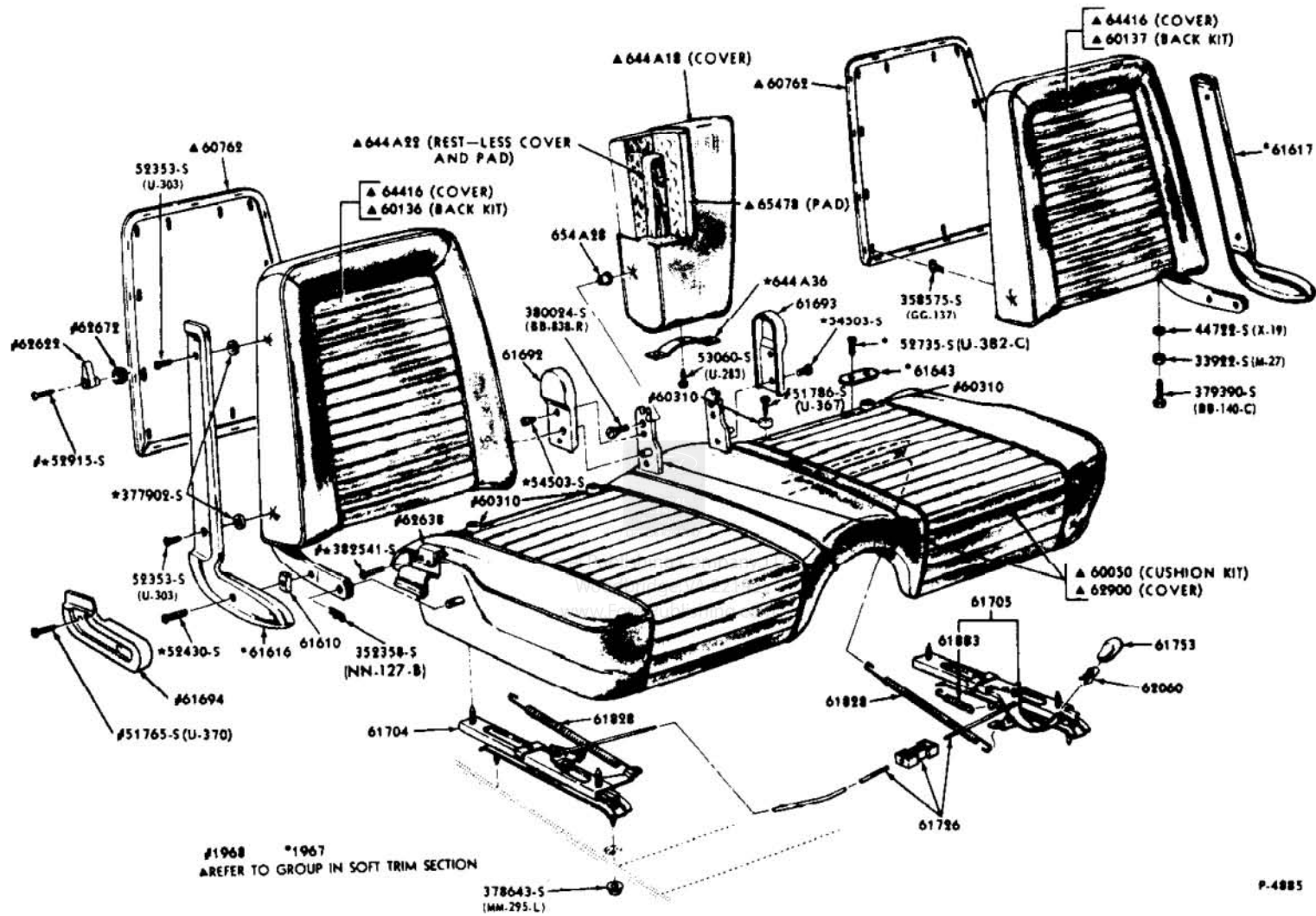

P-4885

FRONT SEAT MECHANISM AND RELATED PARTS - FULL WIDTH
1965 / 69 MUSTANG

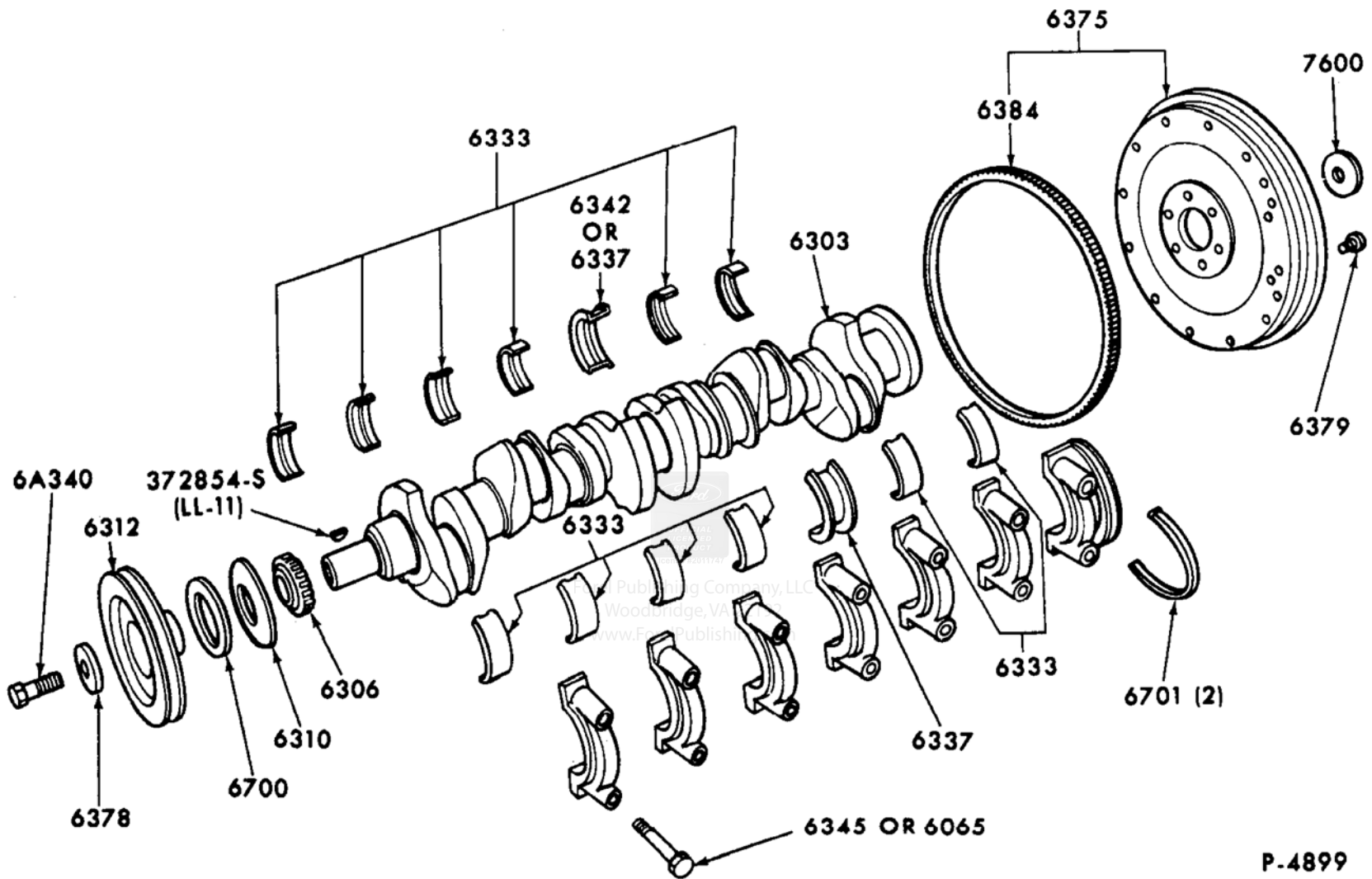

P-4899

ENGINE CRANKSHAFT, FLYWHEEL AND RELATED PARTS -- TYPICAL
1965 / 72 6 CYLINDER 200, 250

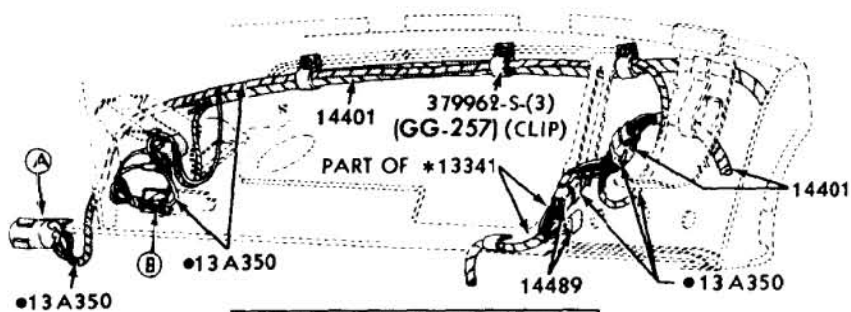

1965 FORD WITH SPEED CONTROL

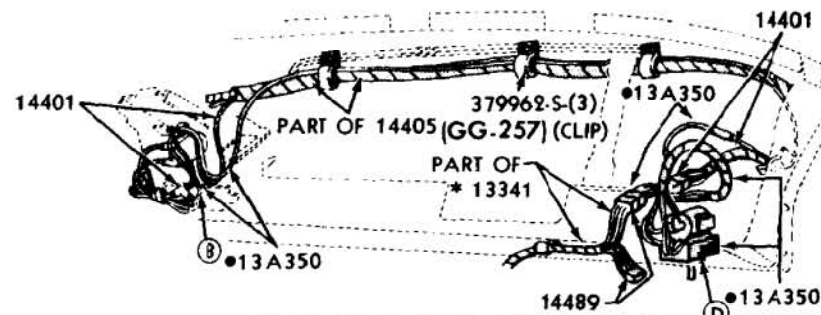

1965 FORD WITHOUT SPEED CONTROL

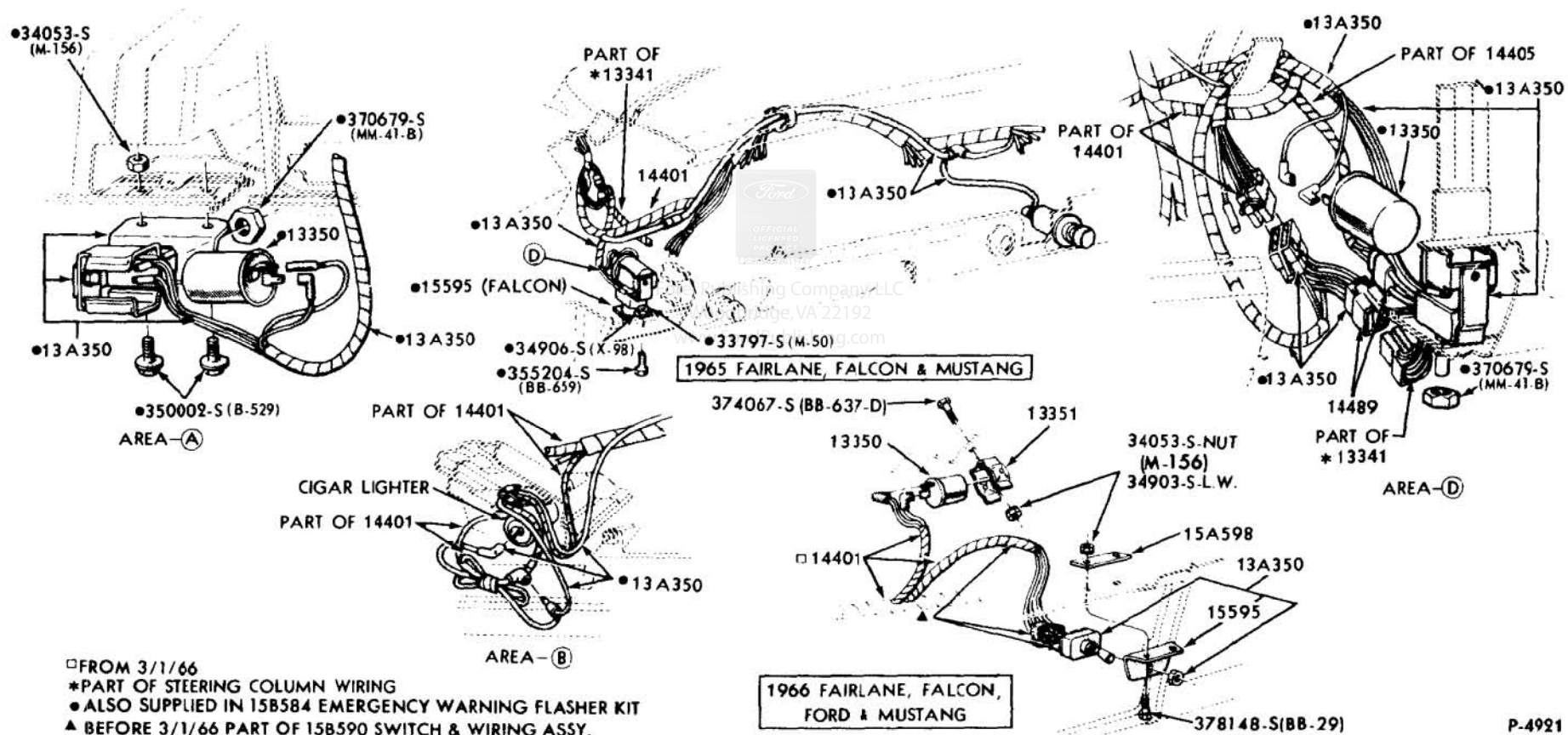

**EMERGENCY WARNING FLASHER AND WIRING SYSTEM
1965 / 66 FORD, FAIRLANE, MUSTANG, FALCON**

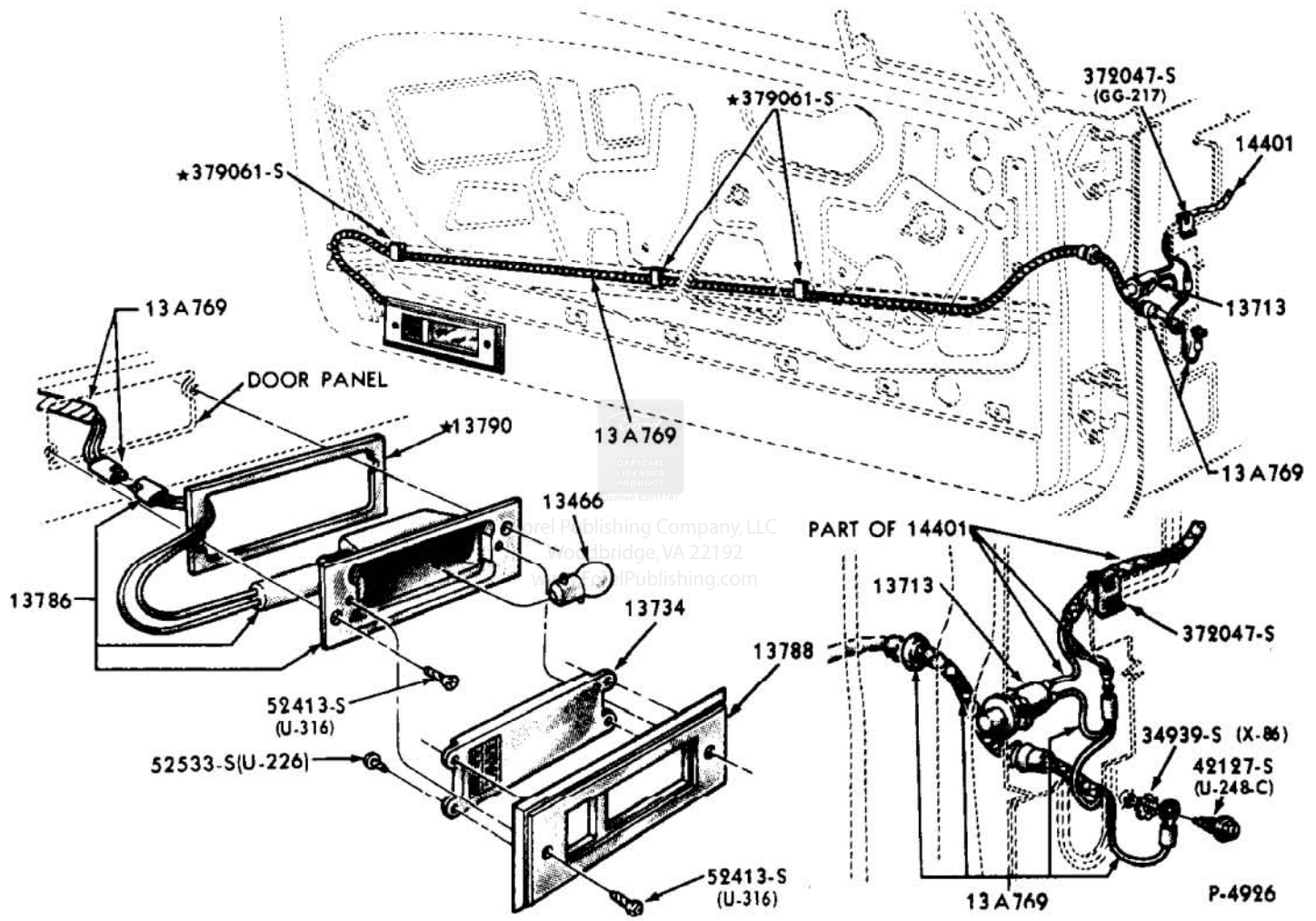

COURTESY LAMP AND WIRING - INTERIOR DOOR
1965 / 66 MUSTANG

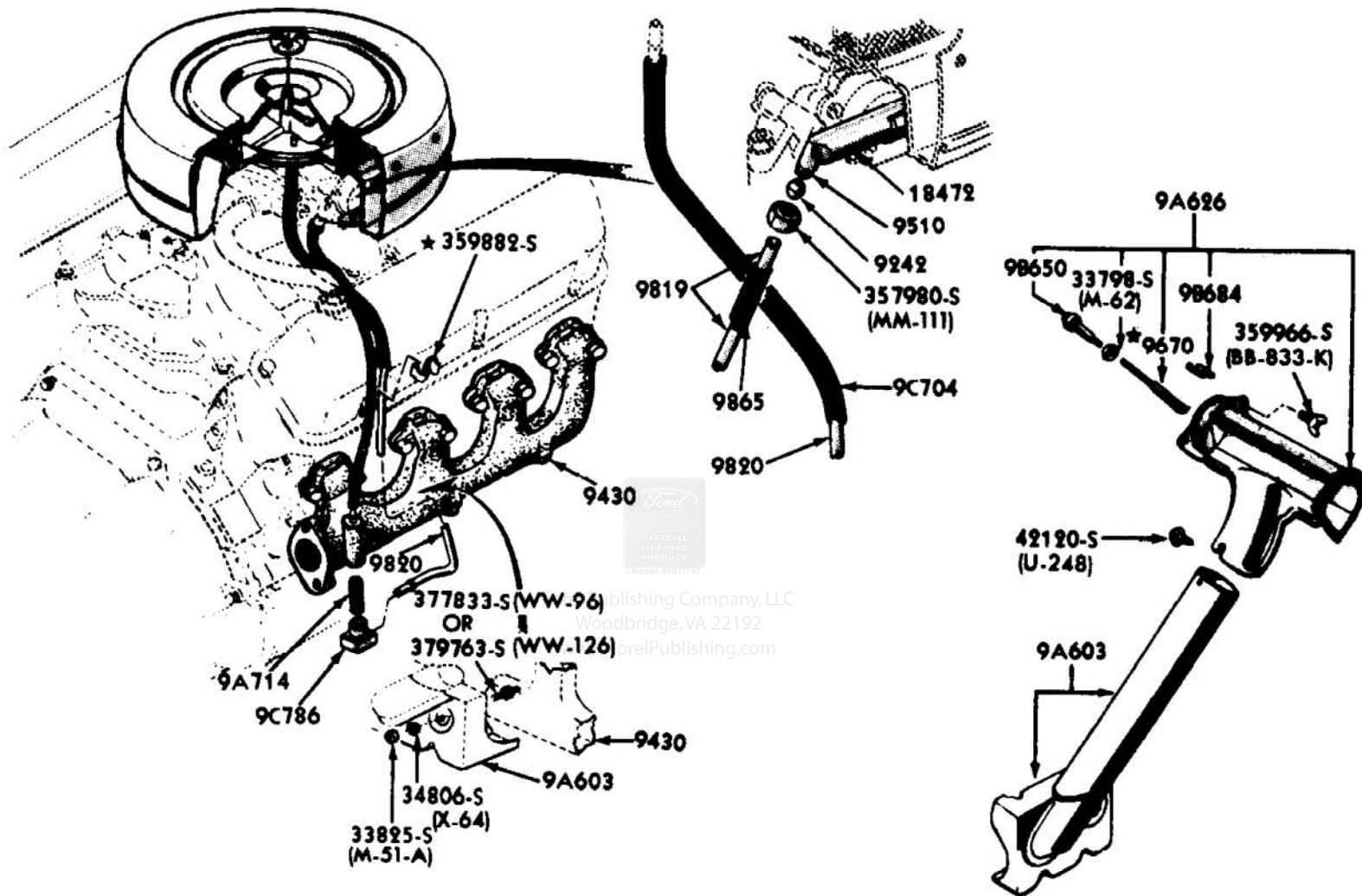

P-4940

THERMOSTATIC CHOKE CONTROL TUBES AND RELATED PARTS
 1965 / 66 FAIRLANE, MUSTANG, FALCON, FORD (8 CYLINDER 260, 289 ENGINE - EXCEPT HIGH PERFORMANCE)

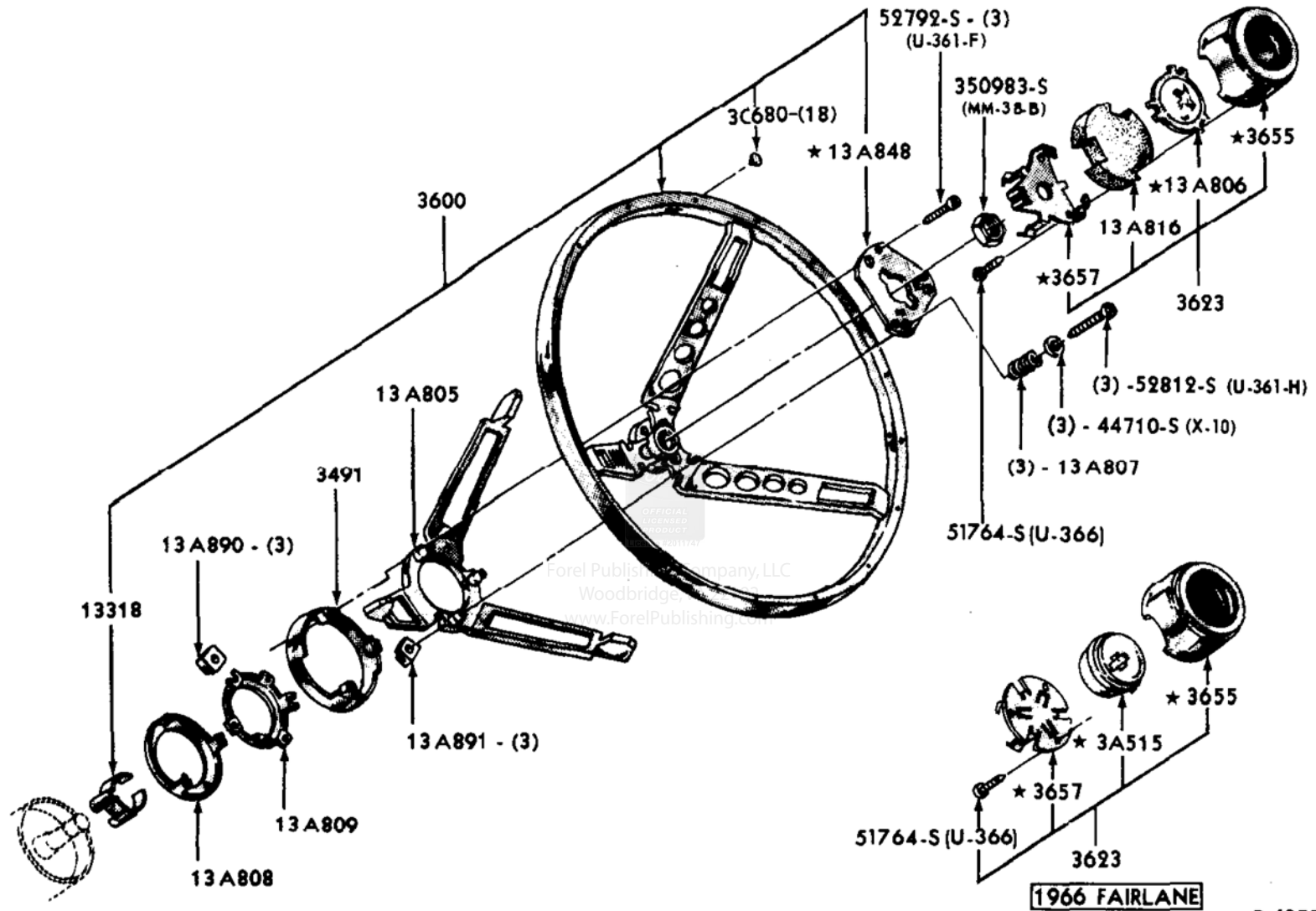

P-4955

HORN RING, STEERING WHEEL AND RELATED PARTS -- WOODGRAIN WHEEL
1965/66 MUSTANG 1966 FORD - 7 LITRE 1966 FAIRLANE

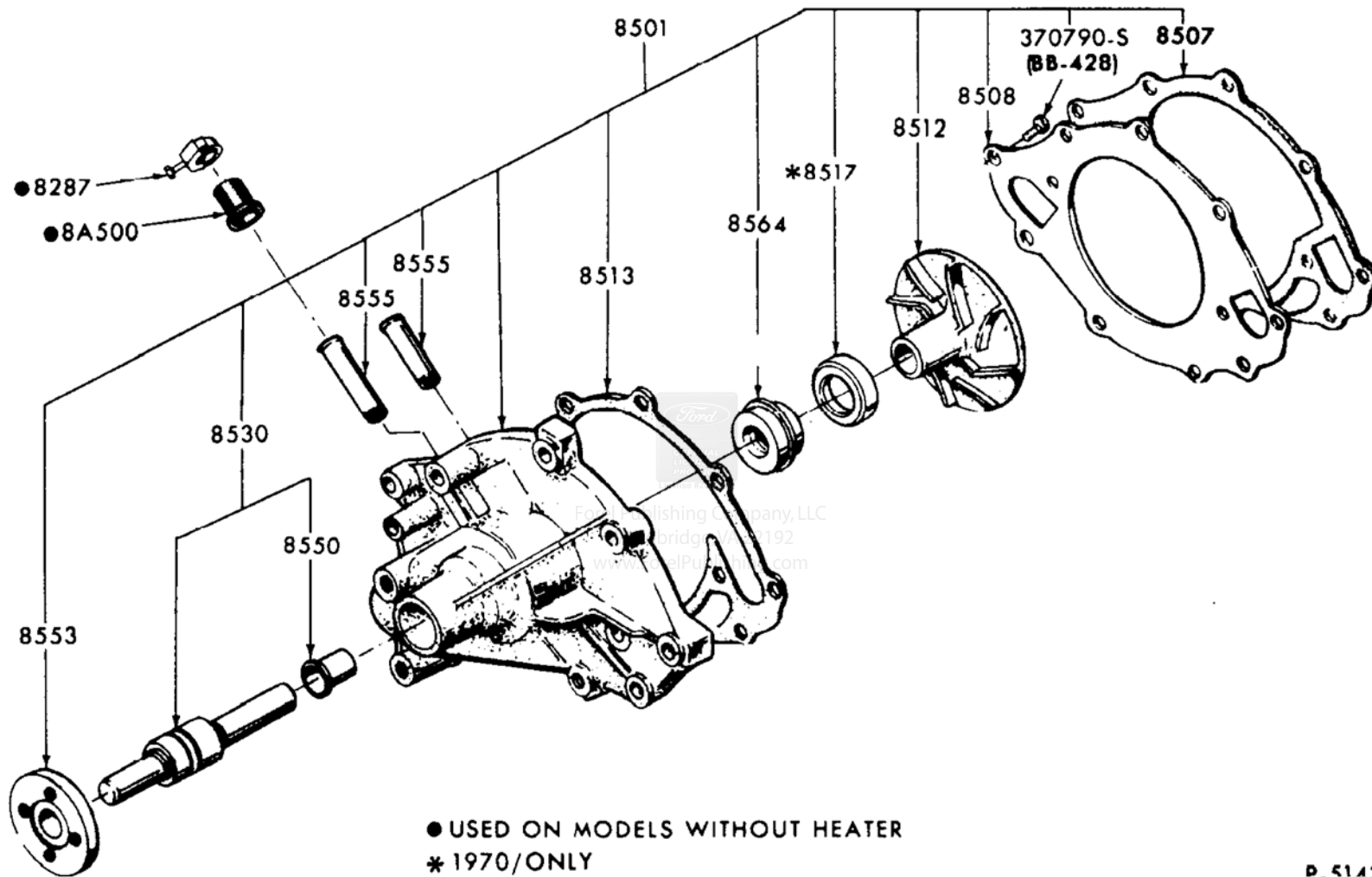

P-5143

WATER PUMP - WITH COVER
1965 / 72 8 CYLINDER 289, 302 AND 351W

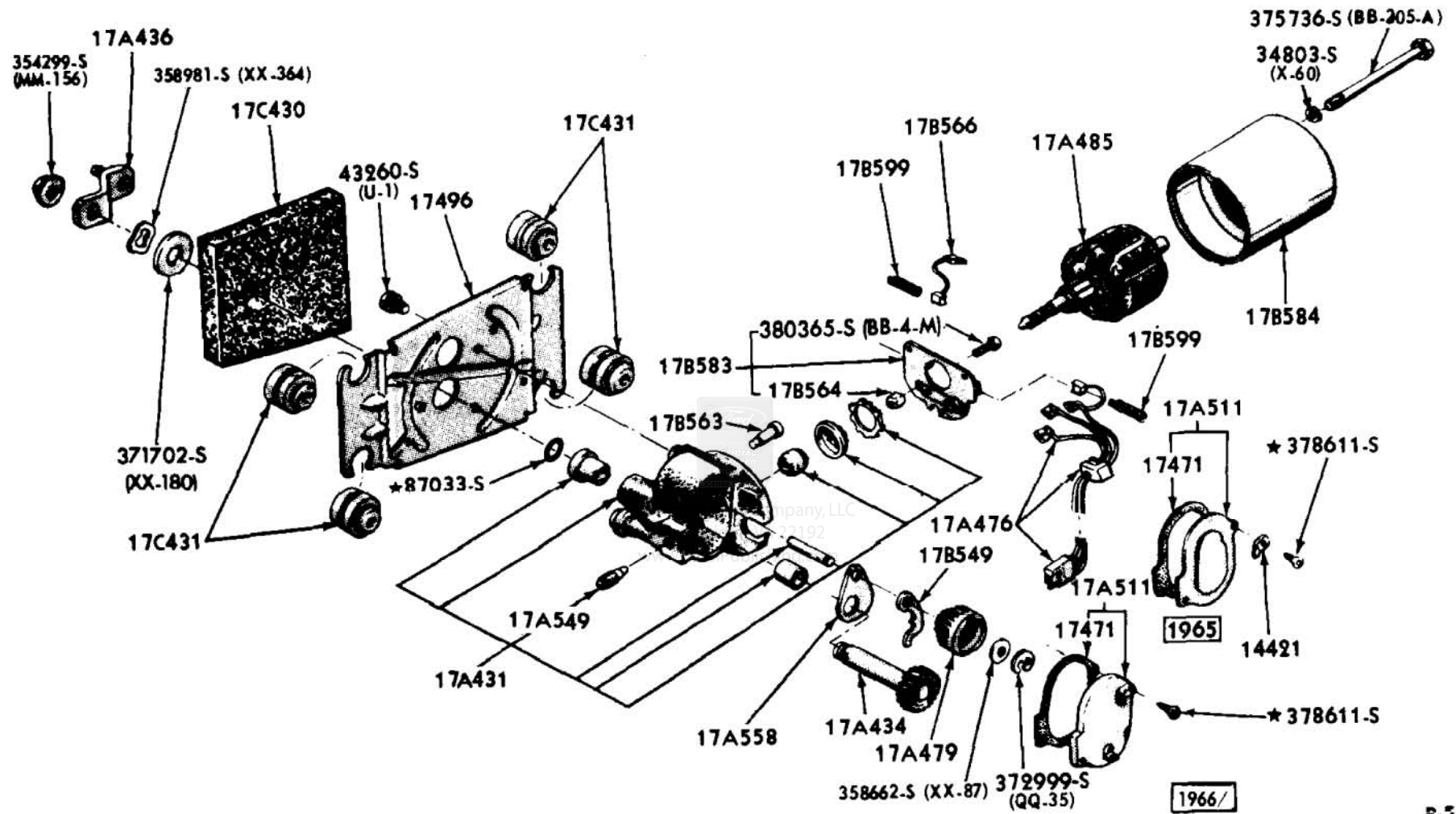

P-5376

WINDSHIELD WIPER MOTOR (SINGLE SPEED FORD ELECTRIC)
1965 / 66 FORD, FAIRLANE, FALCON, AND MUSTANG

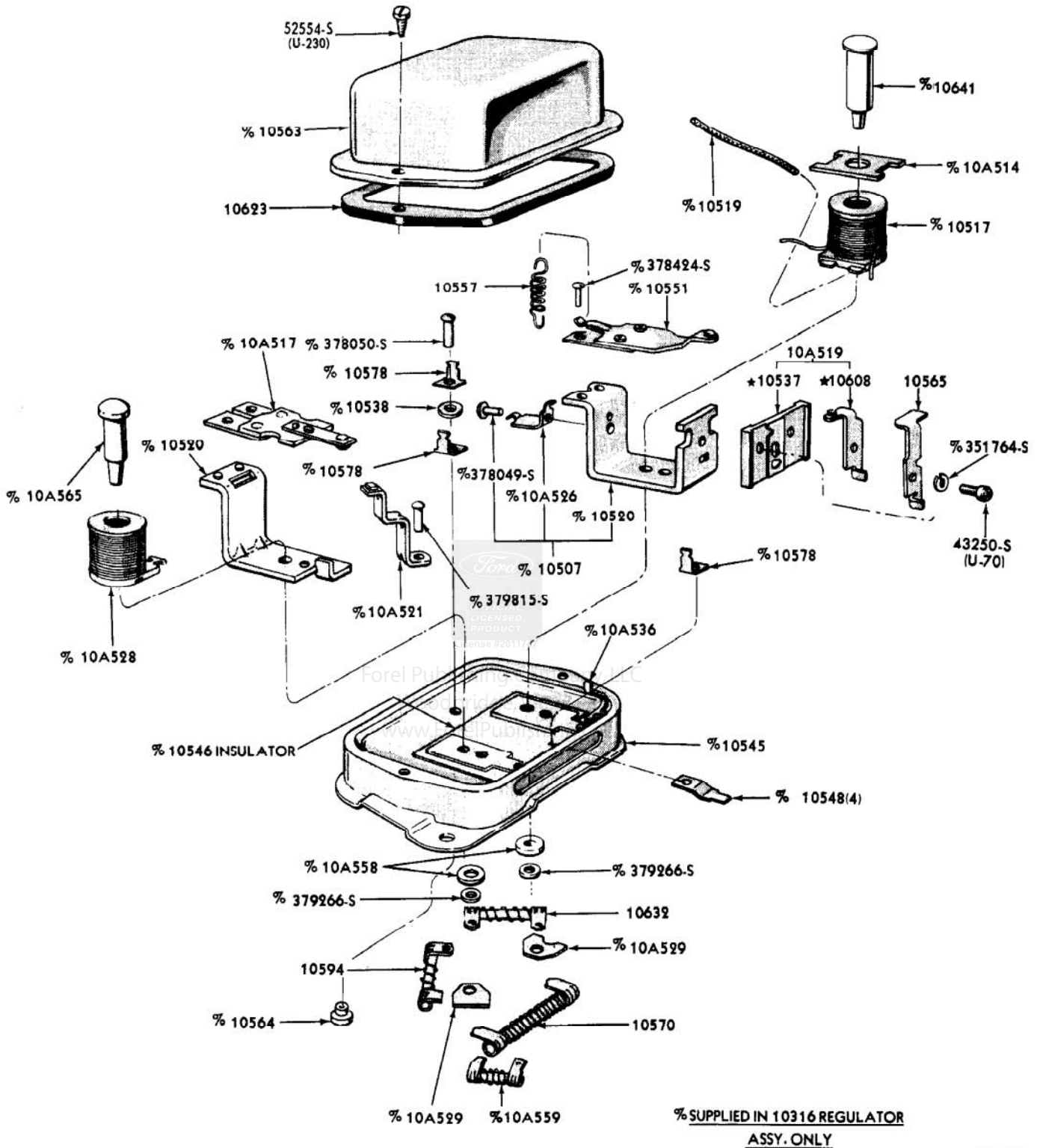

P-5525

**VOLTAGE REGULATOR (FORD 15 VOLT, NEGATIVE GROUND) - ALTERNATOR
1965 / 72**

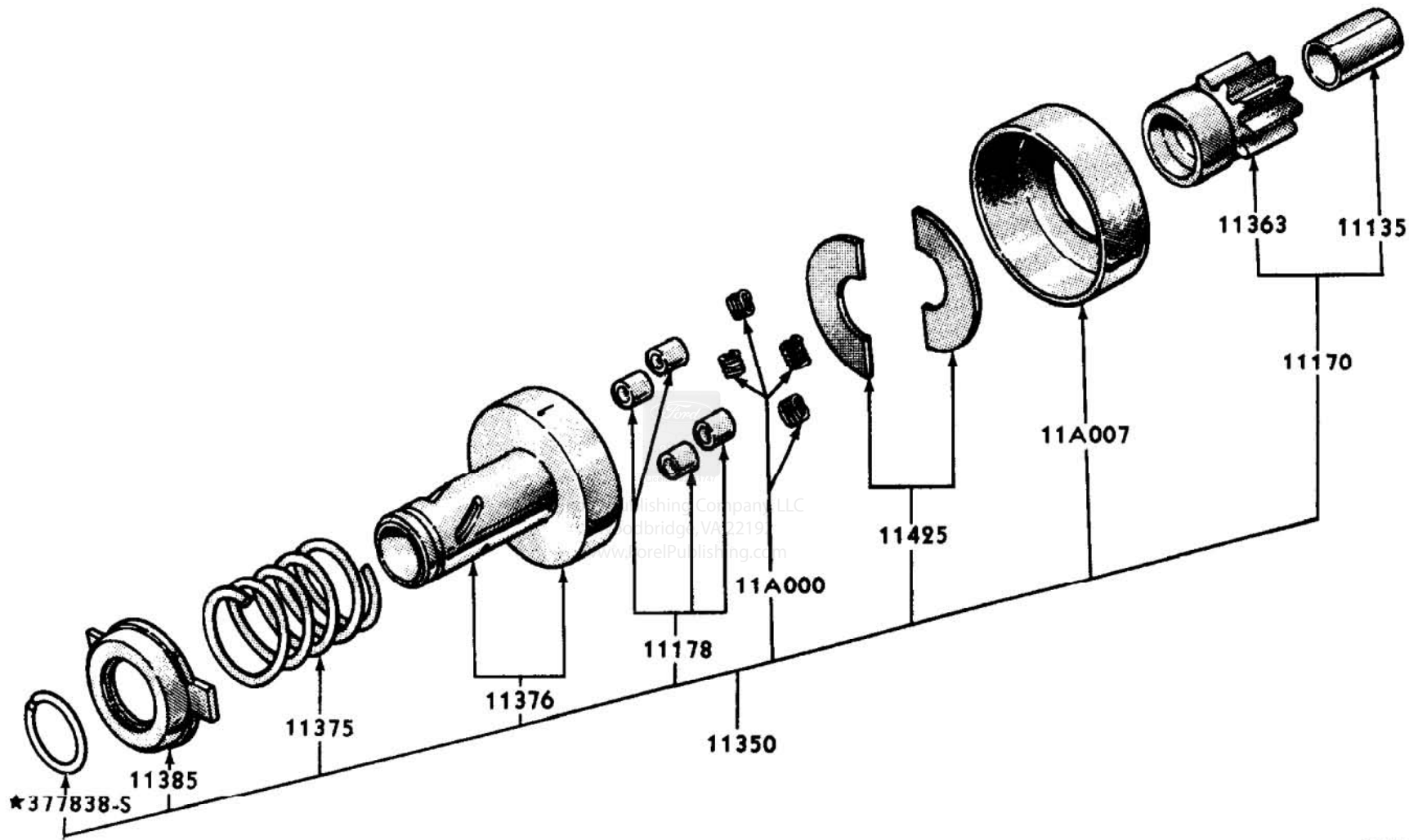

P-5526

STARTER DRIVE (12 VOLT - POSITIVE ENGAGEMENT)
1965 / 72 FORD

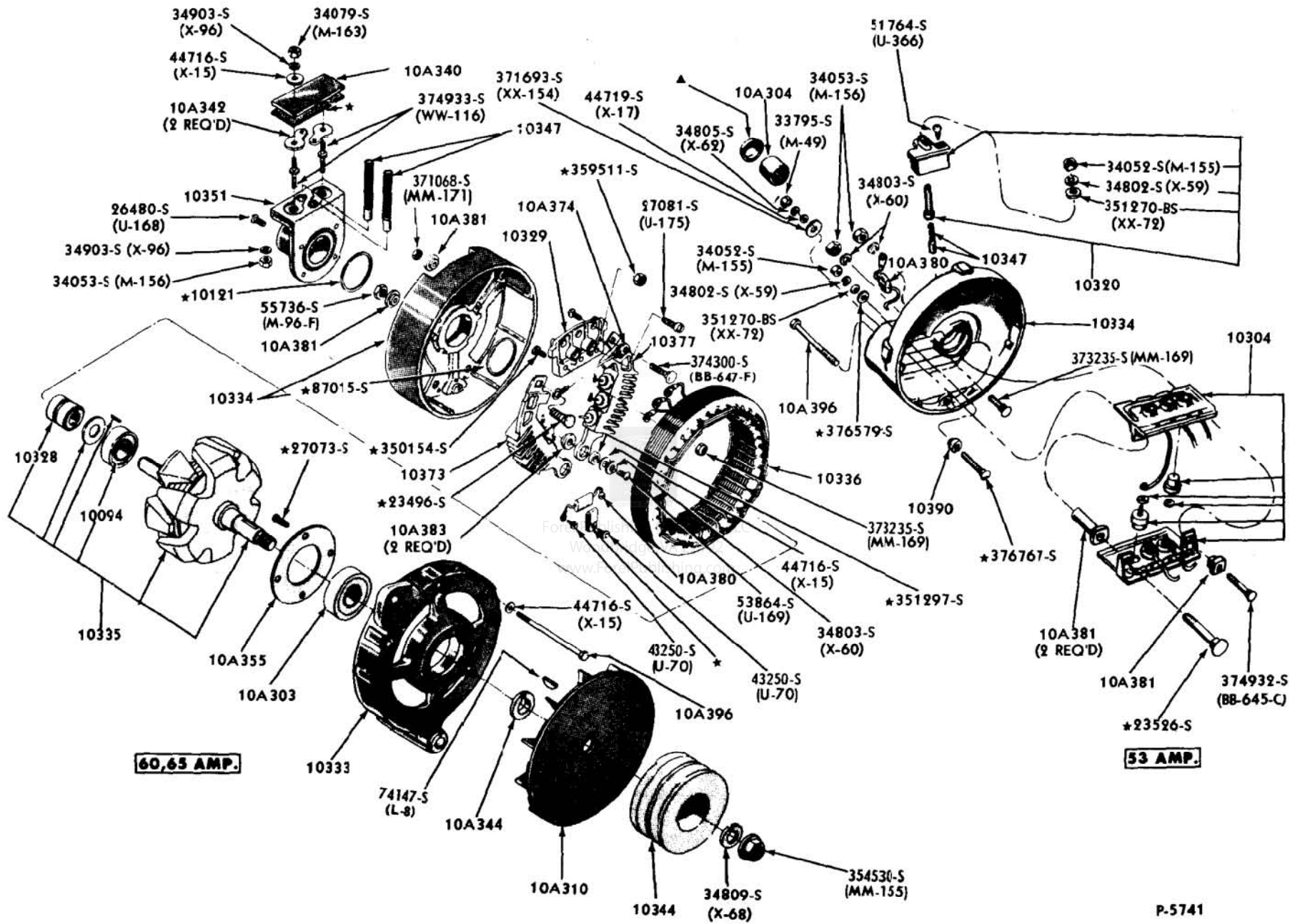

ALTERNATOR (LEECE NEVILLE 15 VOLT - 53, 60, 65 AMP.) - TYPICAL
1965 / 70

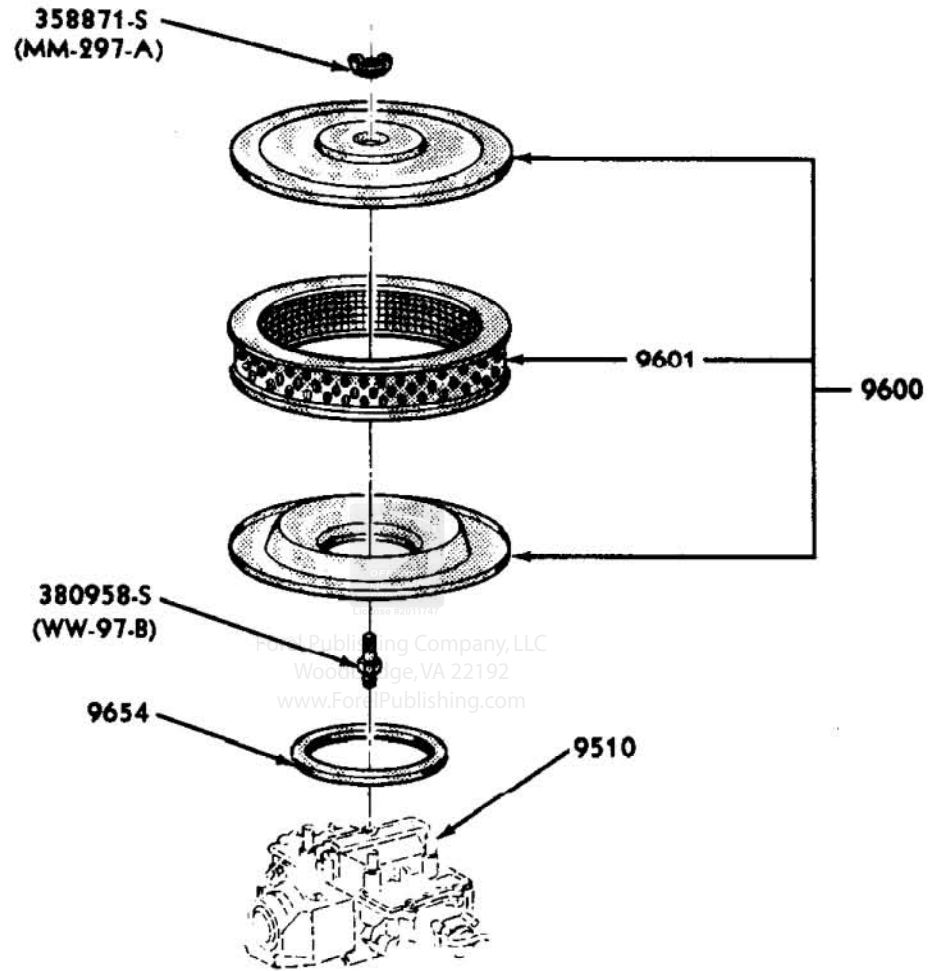

P-5784

AIR CLEANER - 8 CYLINDER
1965 / 67 FAIRLANE, MUSTANG (289 - 4V HIGH PERFORMANCE)
1966 / 68 FORD (427-4V AND 428-4V P.C.) 1967 / 68 FAIRLANE (427-4V)
1968 MUSTANG (427-4V)

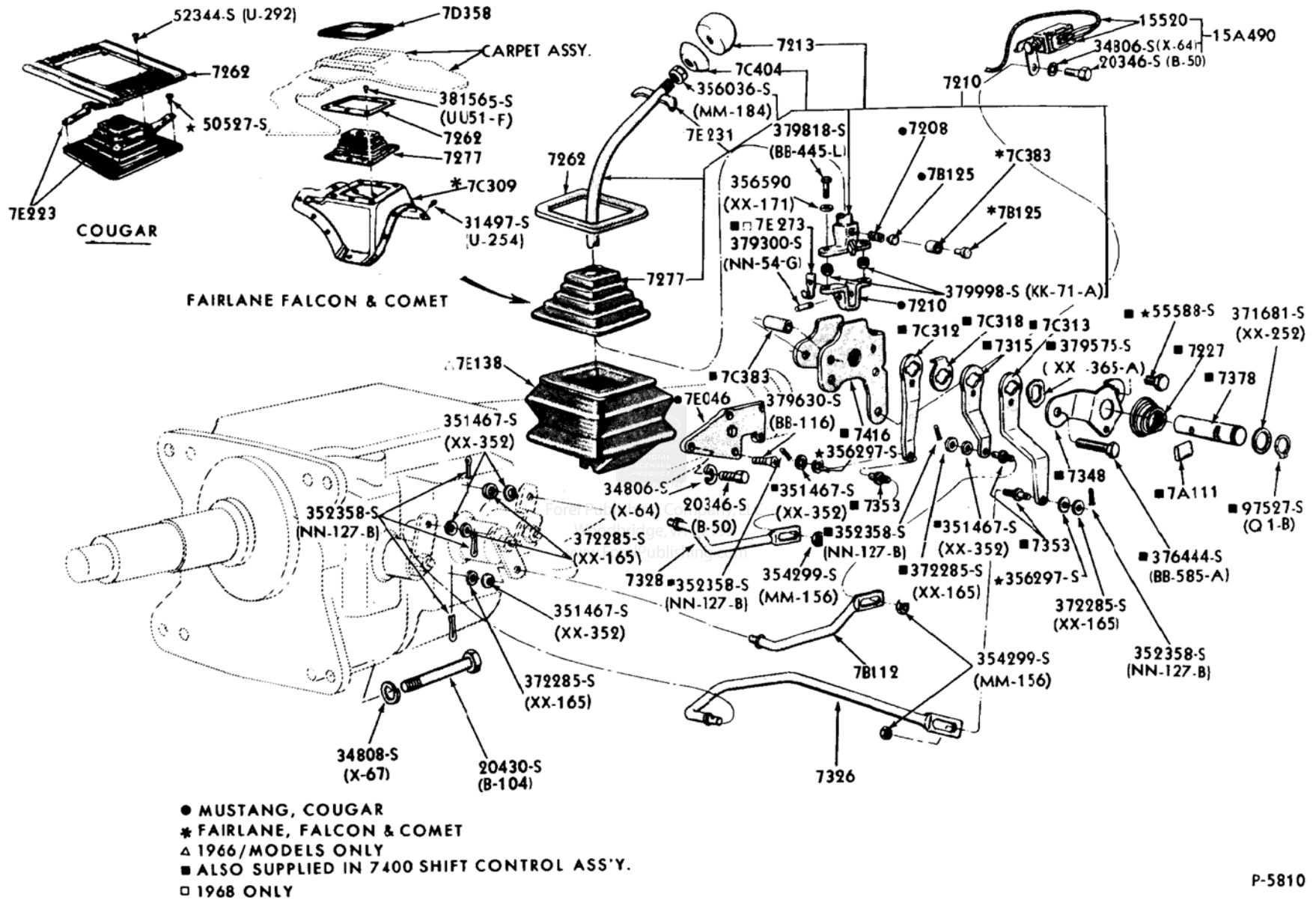

P-5810

**GEAR SHIFT MECHANISM - CONSOLE OR FLOOR MOUNTED - TYPICAL
 4 SPEED MANUAL TRANSMISSION - FORD DESIGN
 1965 / 68 FAIRLANE / TORINO, MUSTANG & FALCON**

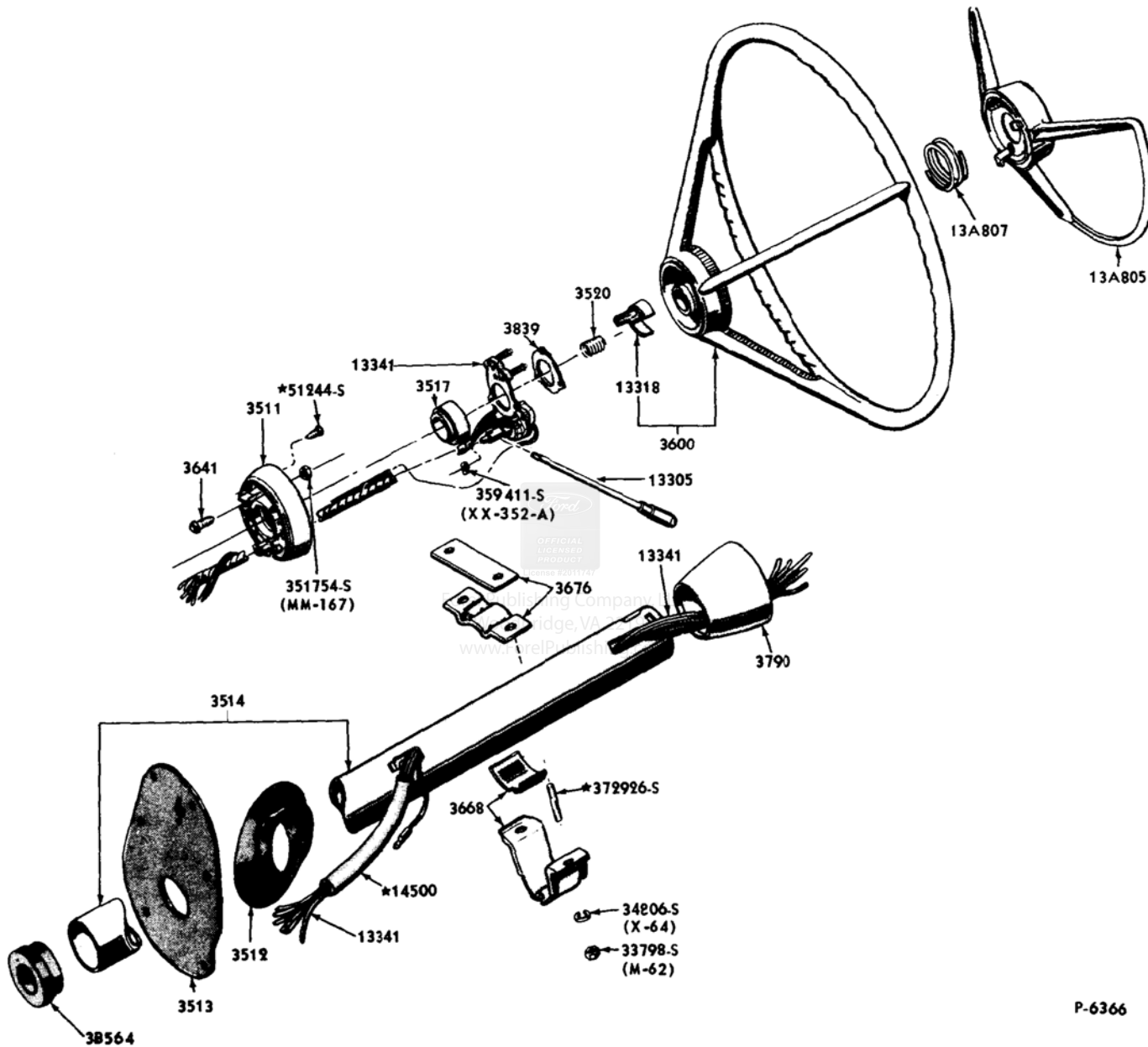

P-6366

**STEERING COLUMN FOR FLOOR SHIFT
1965 FALCON, 1965/66 MUSTANG**

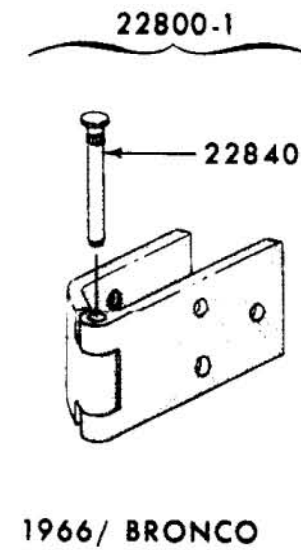
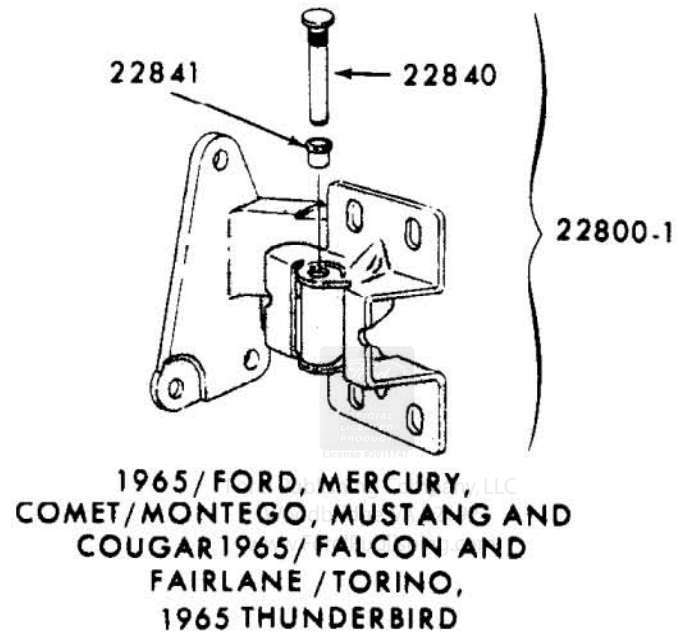
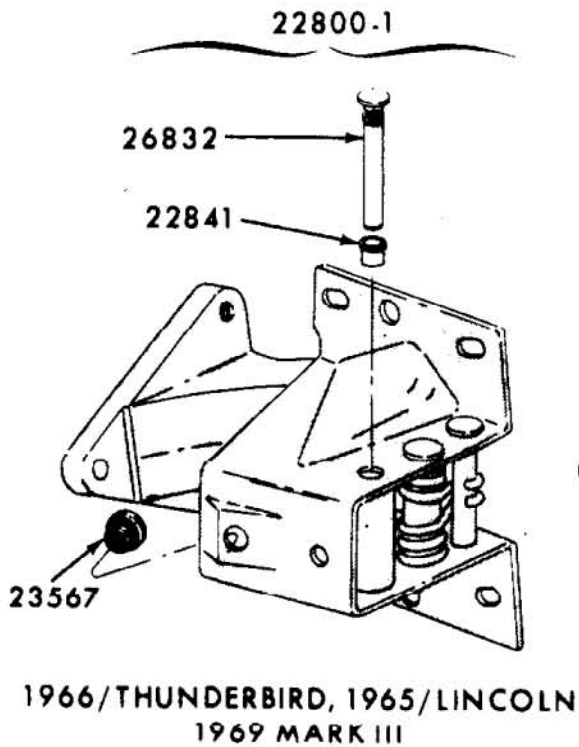

P-6980

FRONT DOOR HINGES - UPPER
1965/72 ALL

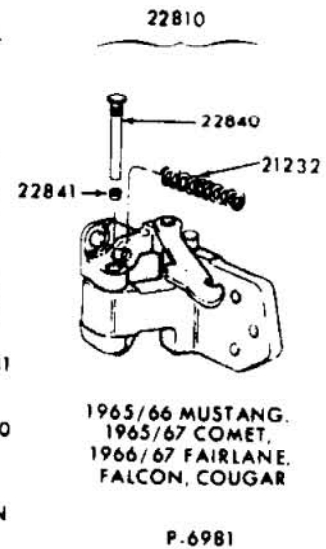
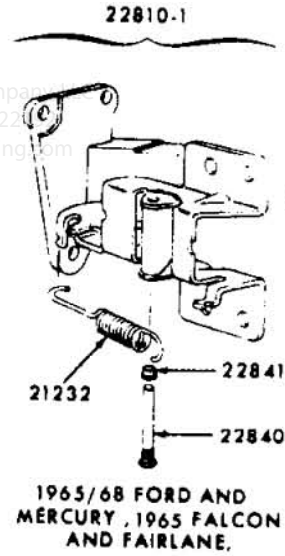
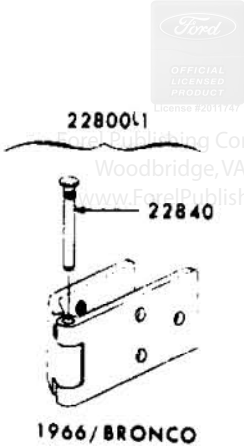
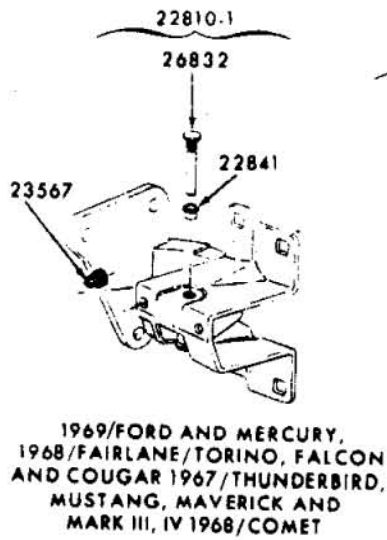
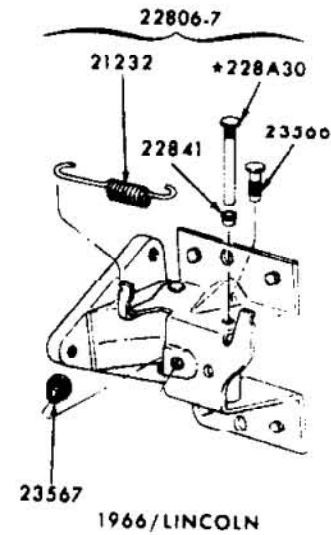
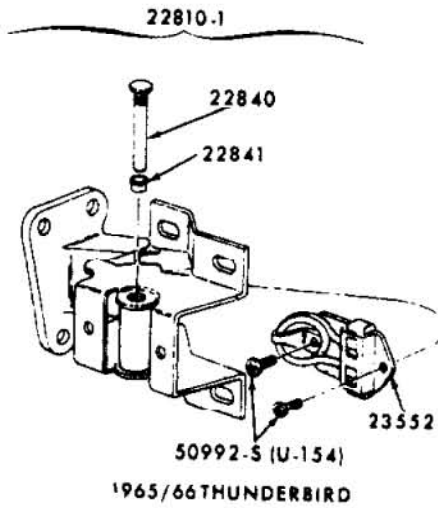
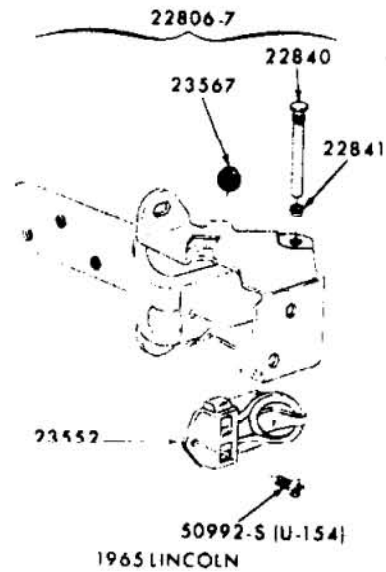

**FRONT DOOR HINGES - LOWER
1965 / 72 ALL**

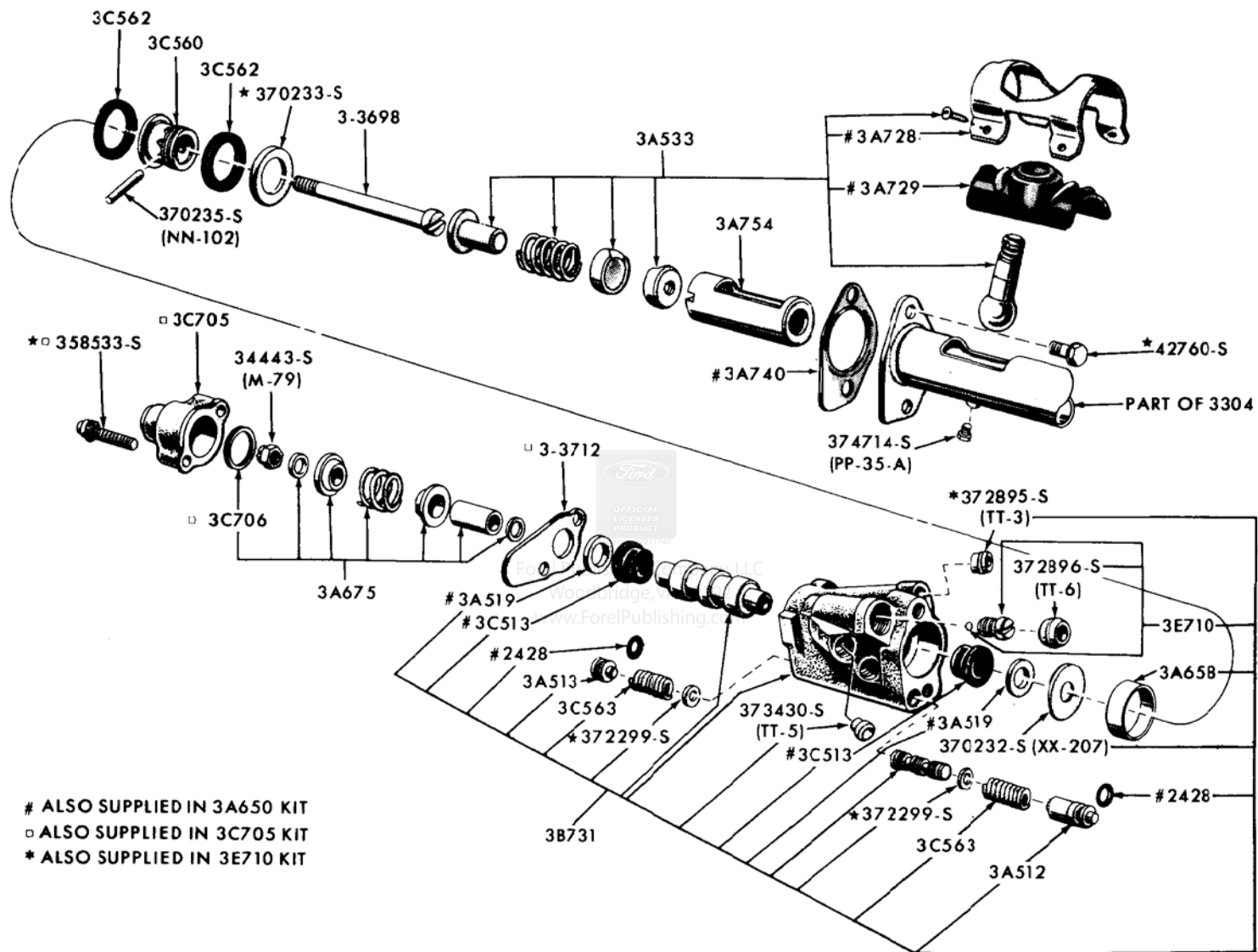

P-7453

**POWER STEERING CONTROL VALVE DETAILS - TYPICAL
1965 FALCON - 8 CYLINDER, 1965/66 MUSTANG - 8 CYLINDER**

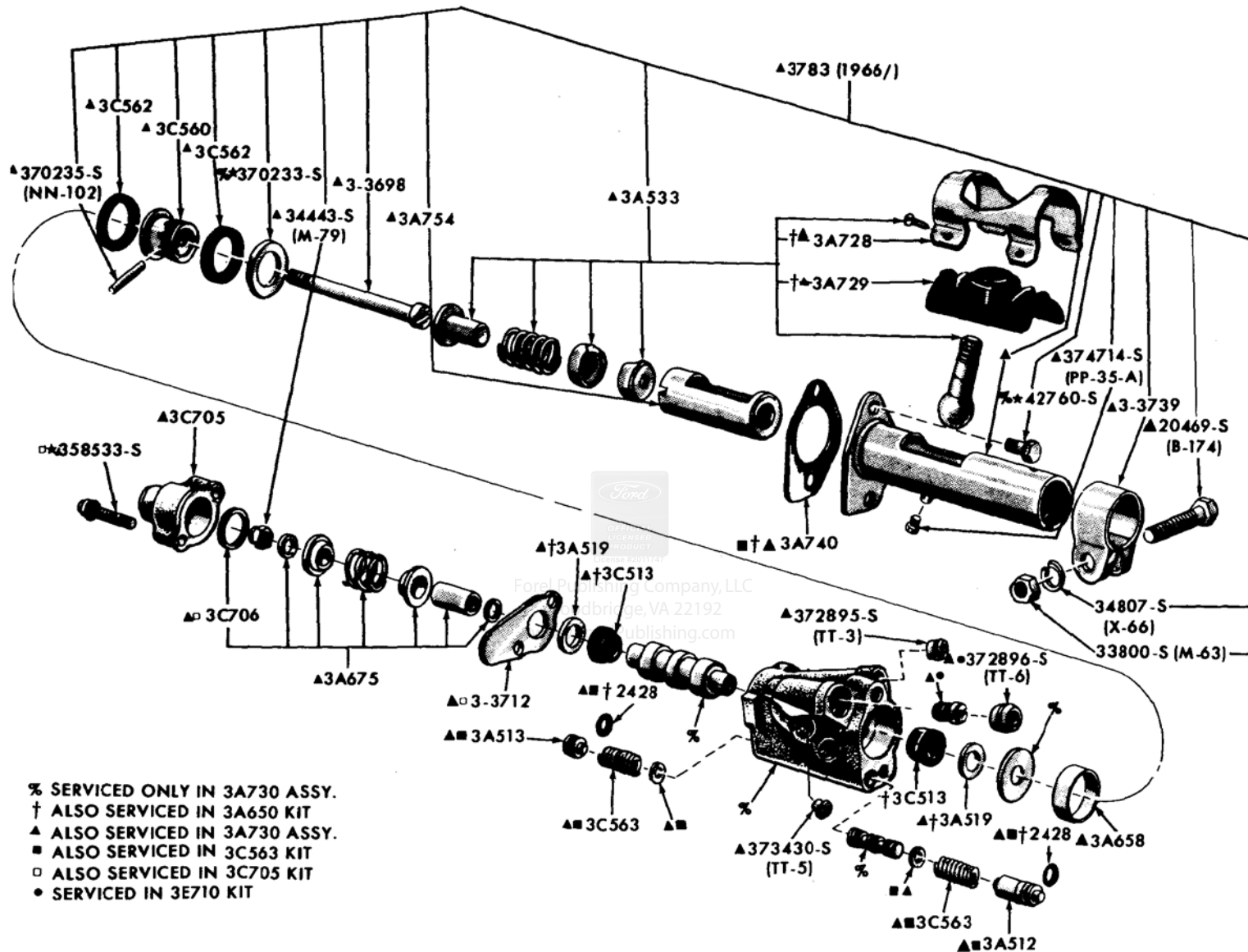

P-7454

POWER STEERING CONTROL VALVE DETAILS - TYPICAL
 1965/71 FAIRLANE/TORINO, 1965/70 FALCON - 6 CYL., 1966/70 FALCON - 8 CYL.
 1970/72 MAVERICK, 1965/66 MUSTANG - 6 CYL., 1967/70 MUSTANG

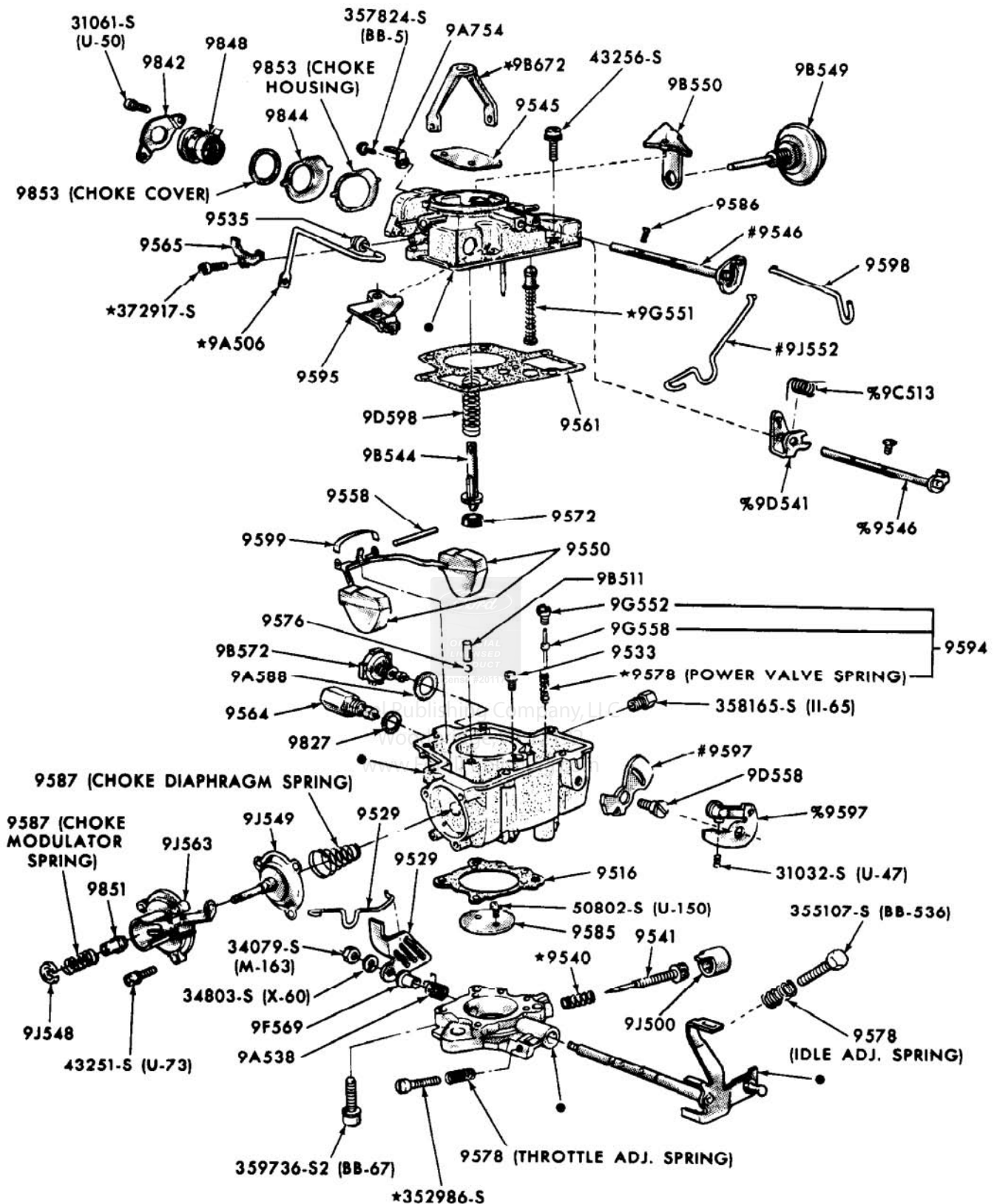

● SUPPLIED ONLY IN 9510 CARBURETOR ASSY.
 %MANUAL CHOKE
 #AUTOMATIC CHOKE

P-7460

CARBURETOR - HOLLEY 1V

1965 / 69 FORD, FAIRLANE, MUSTANG, FALCON (6 CYLINDER 170, 200, 240, 250 ENGINES)

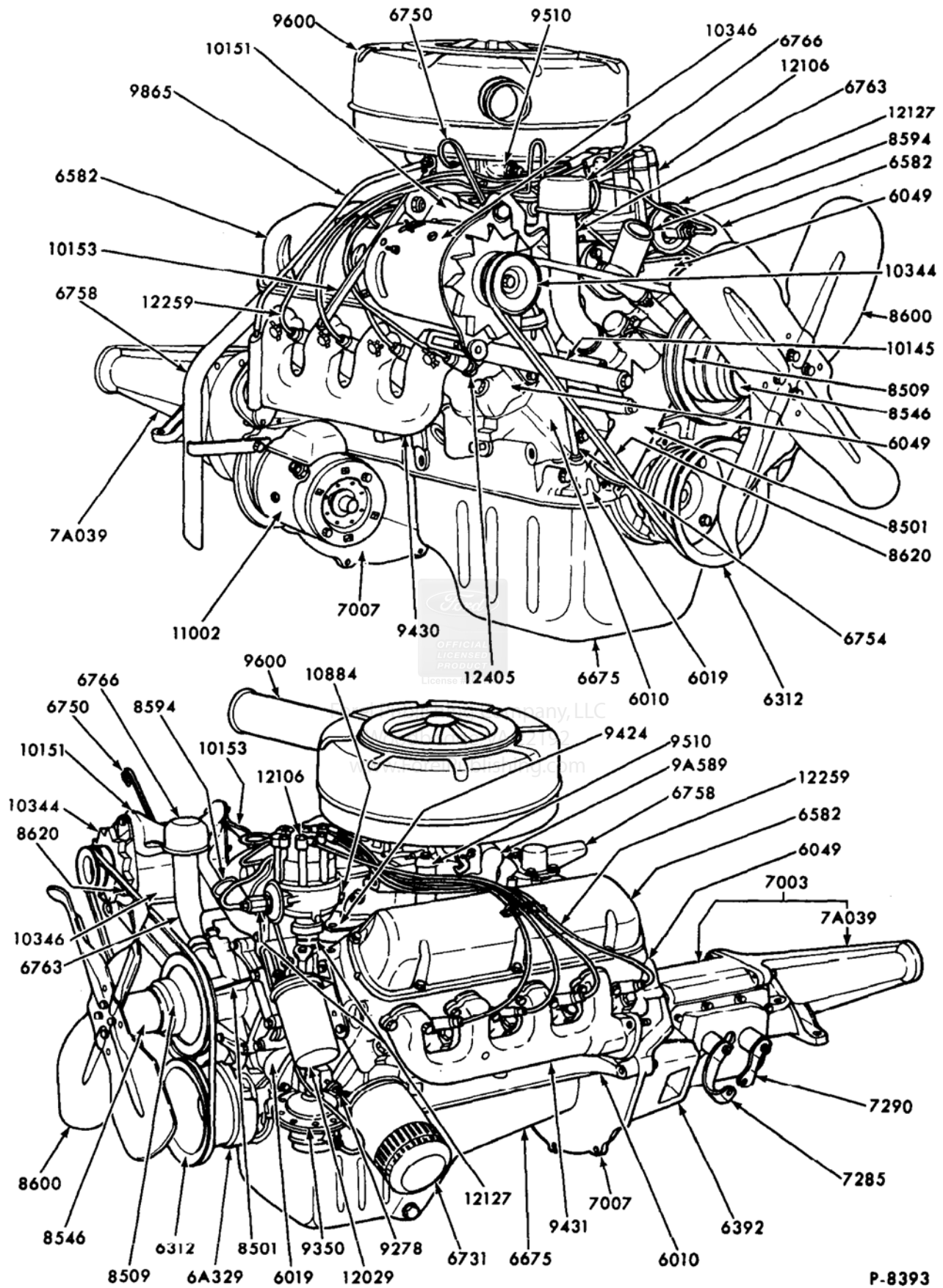

P-8393

ENGINE ASSEMBLY - 8 CYLINDER 260 TYPICAL
1965

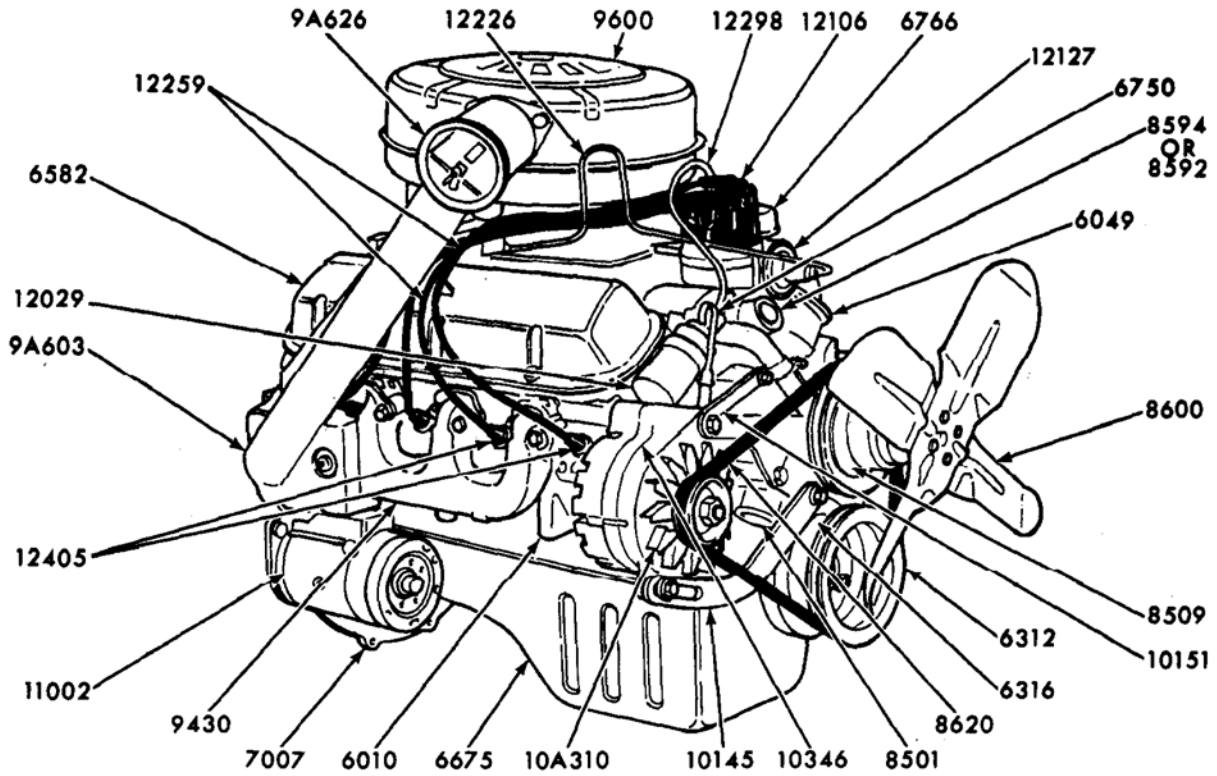

RIGHT-FRONT VIEW

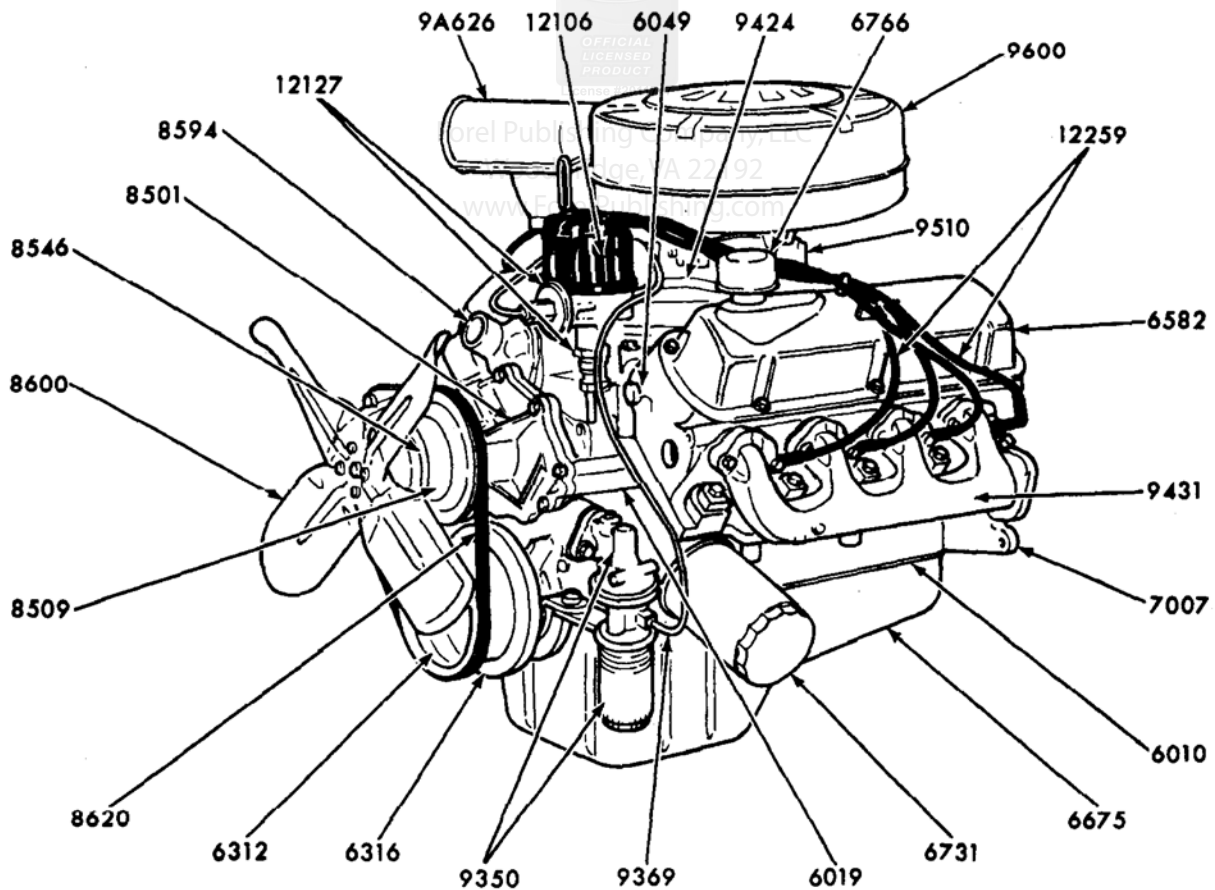

LEFT-FRONT VIEW

P-8396

**ENGINE ASSEMBLY - 8 CYLINDER 289 - TYPICAL
1965 / 68**

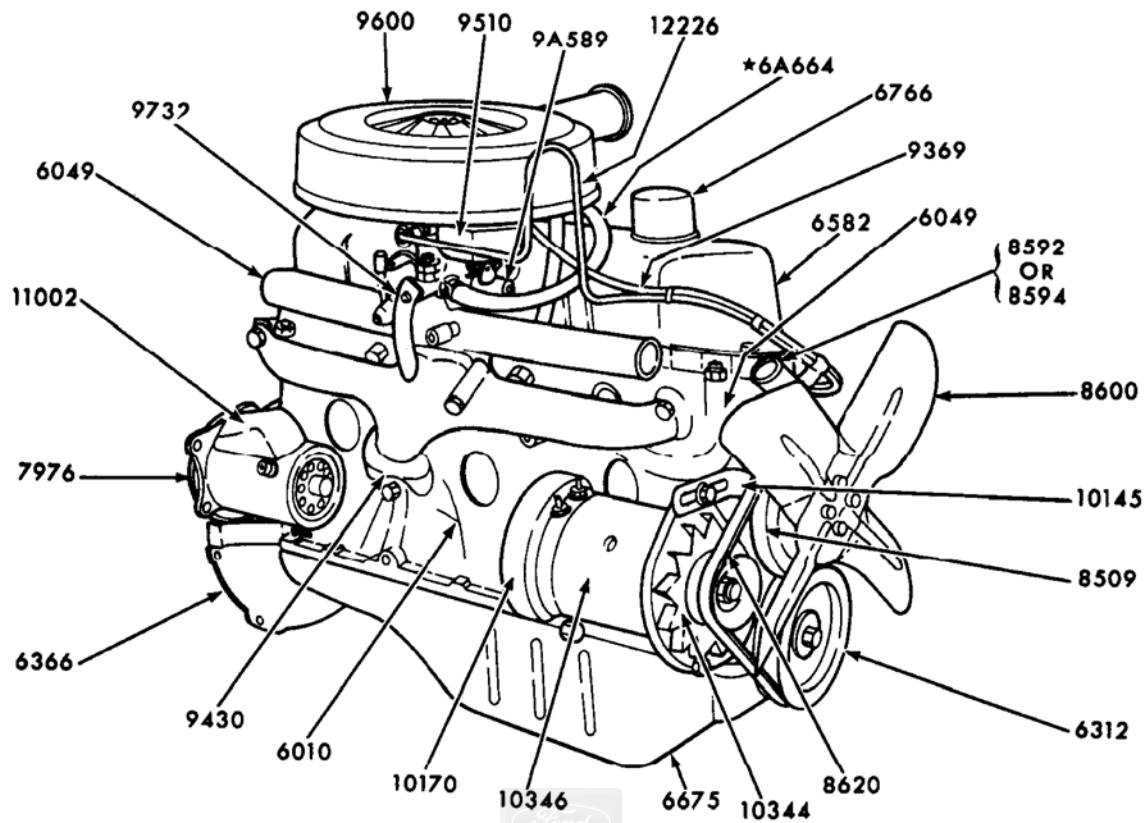

RIGHT-FRONT VIEW

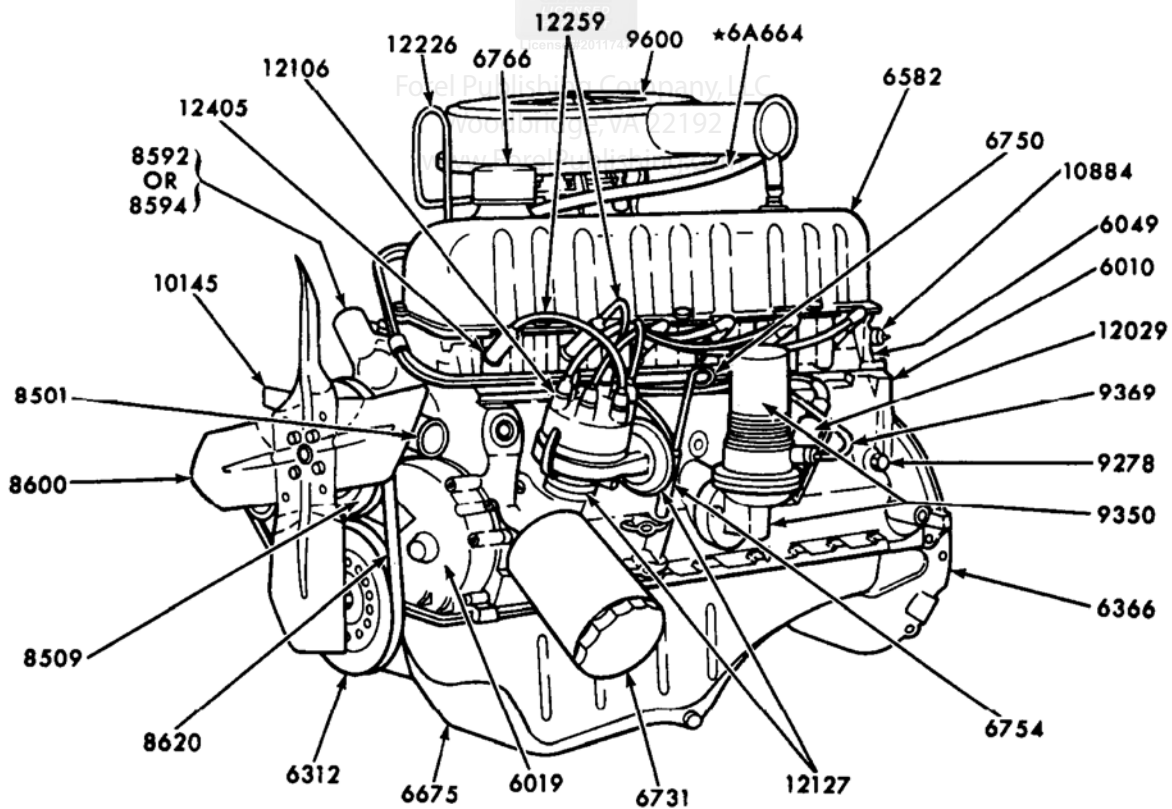

LEFT-FRONT VIEW

P-8398

**ENGINE ASSEMBLY - 6 CYLINDER 170, 200 AND 250 - TYPICAL
1965 / 72**

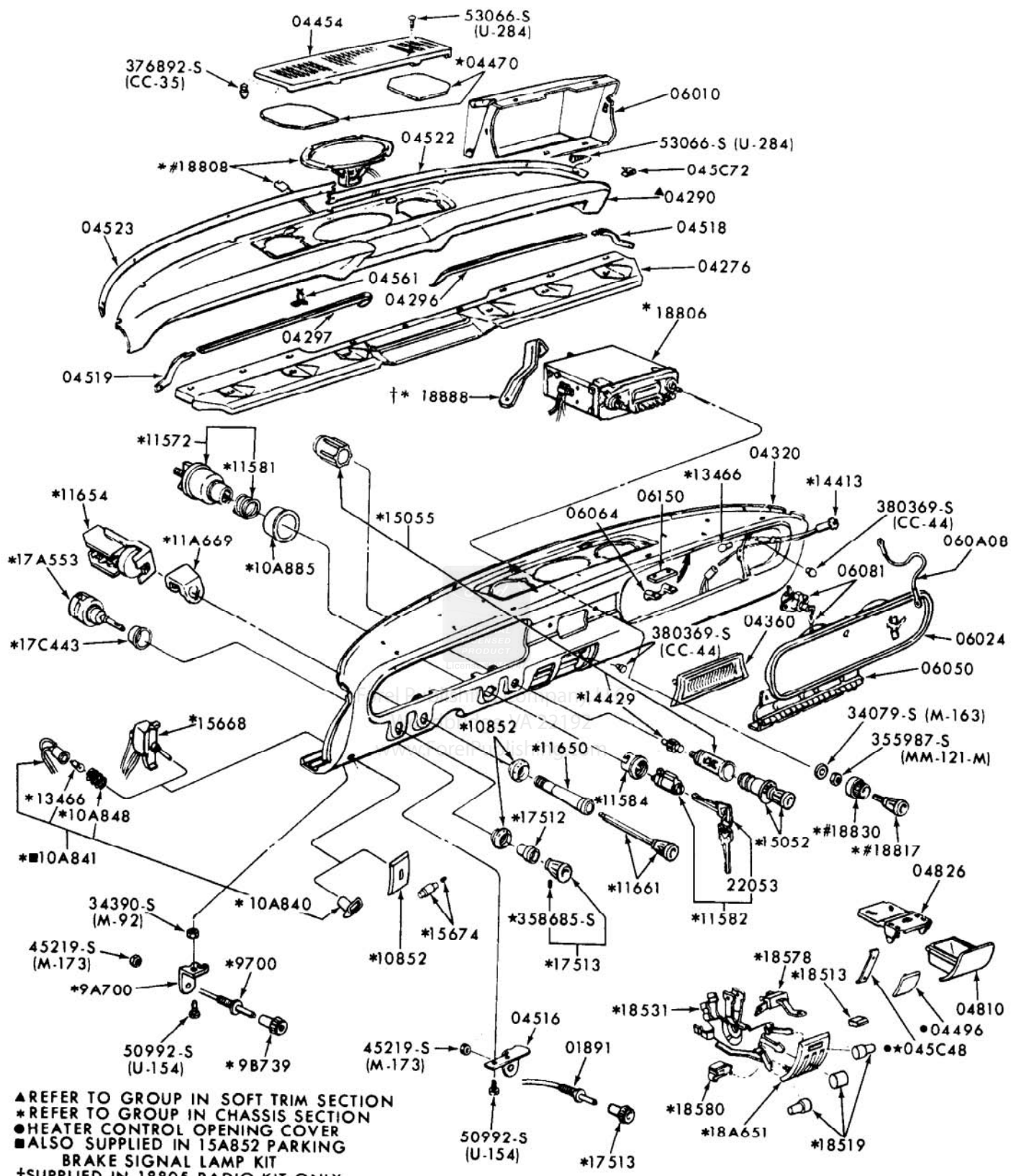

INSTRUMENT PANEL, PAD AND RELATED PARTS
1965 / 66 MUSTANG - W/ GAUGES

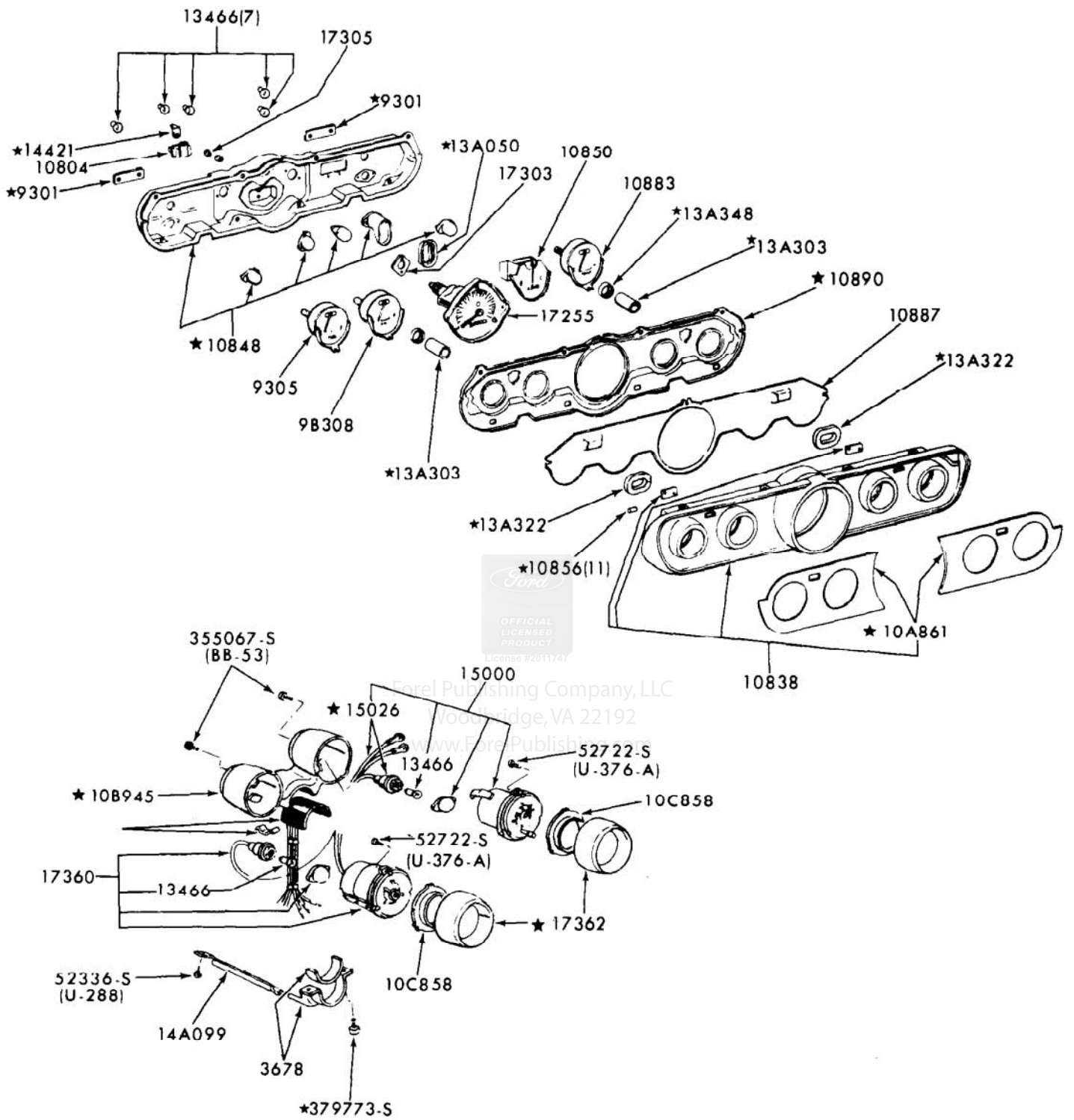

**INSTRUMENT CLUSTER AND RELATED PARTS
1965 / 66 MUSTANG WITH GAUGES**

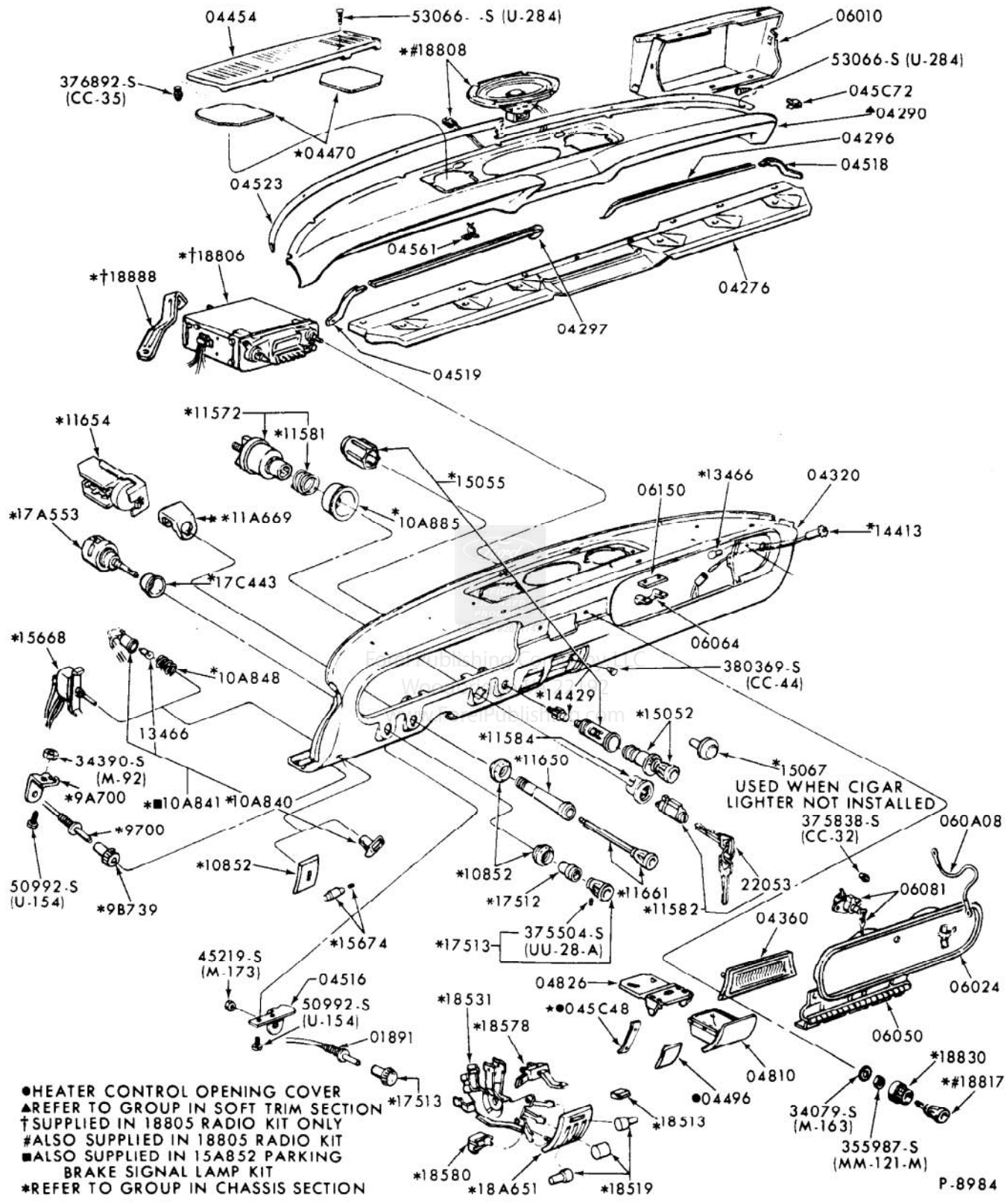

INSTRUMENT PANEL, PAD AND RELATED PARTS
1965 MUSTANG - W/ INDICATOR LIGHTS

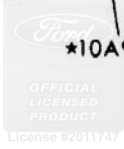
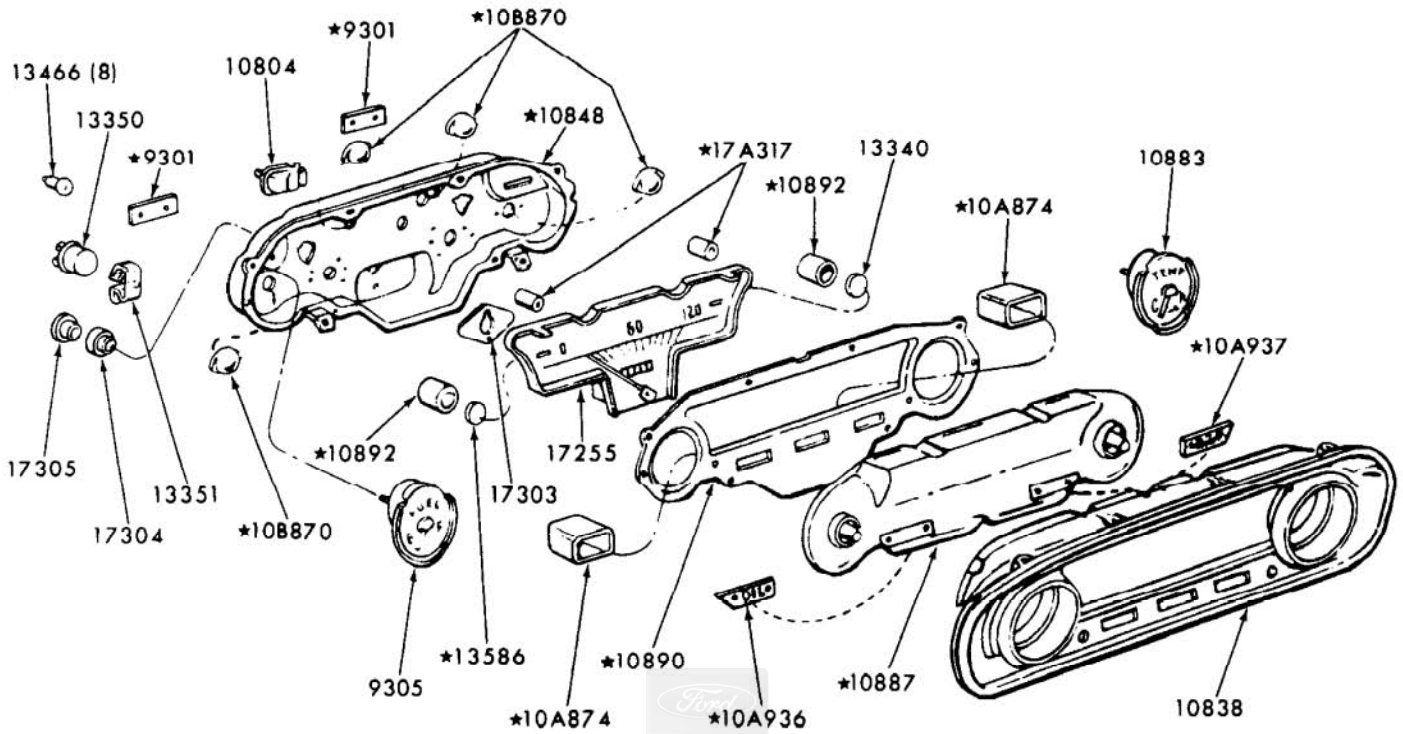

Forel Publishing Company, LLC
 Woodbridge, VA 22192
 www.forelpublishing.com

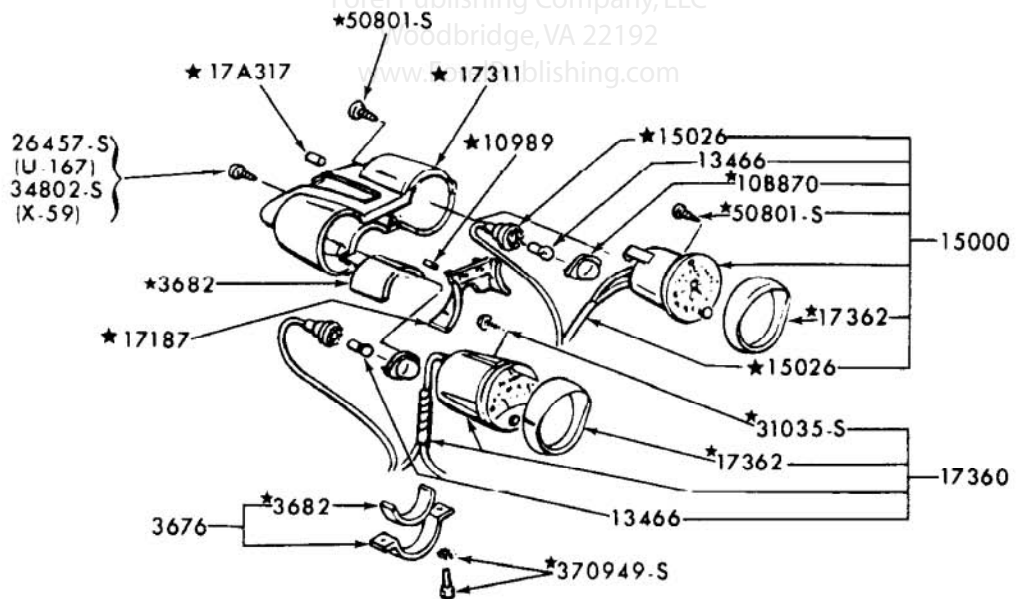

**INSTRUMENT CLUSTER AND RELATED PARTS
 1965 MUSTANG - WITH WARING LIGHTS**

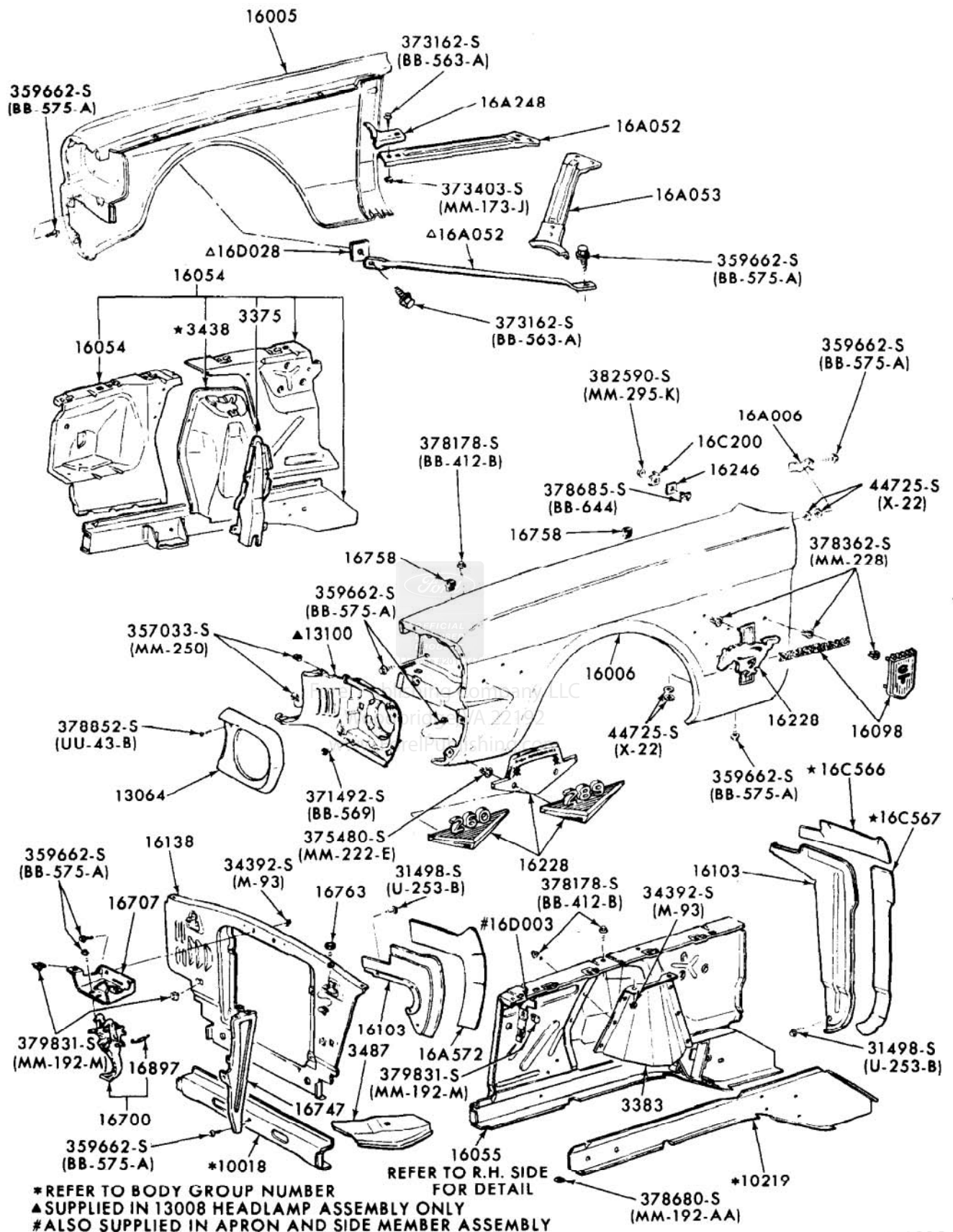

*REFER TO BODY GROUP NUMBER
 ▲SUPPLIED IN 13008 HEADLAMP ASSEMBLY ONLY
 #ALSO SUPPLIED IN APRON AND SIDE MEMBER ASSEMBLY
 ΔMODEL 76 (1966)

REFER TO R.H. SIDE
 FOR DETAIL

FENDERS, APRONS AND RELATED PARTS
1965 / 66 MUSTANG

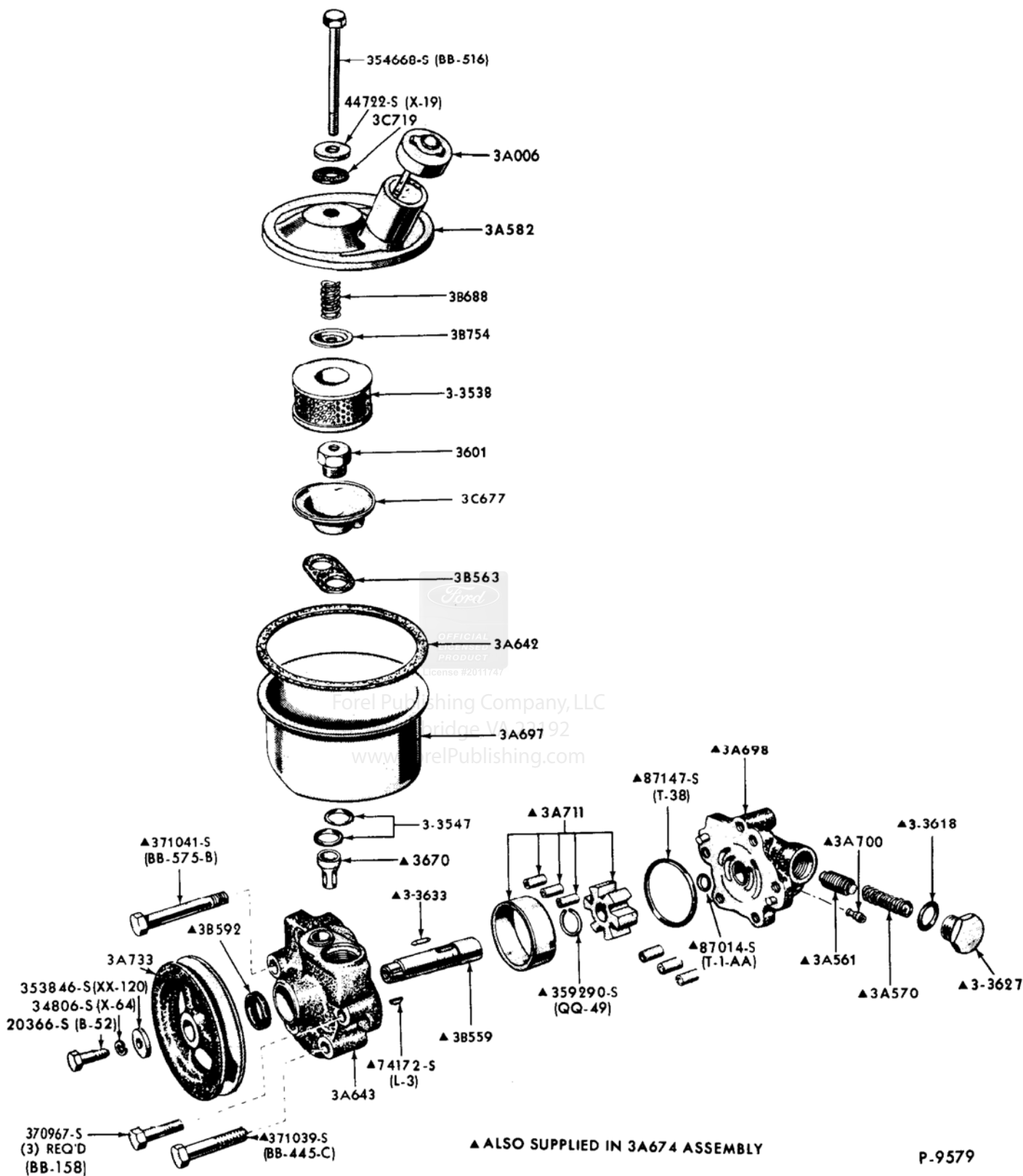

**POWER STEERING PUMP & RELATED PARTS - (EATON TYPE)
 1965 FORD, FAIRLANE, FALCON, MUSTANG & THUNDERBIRD**

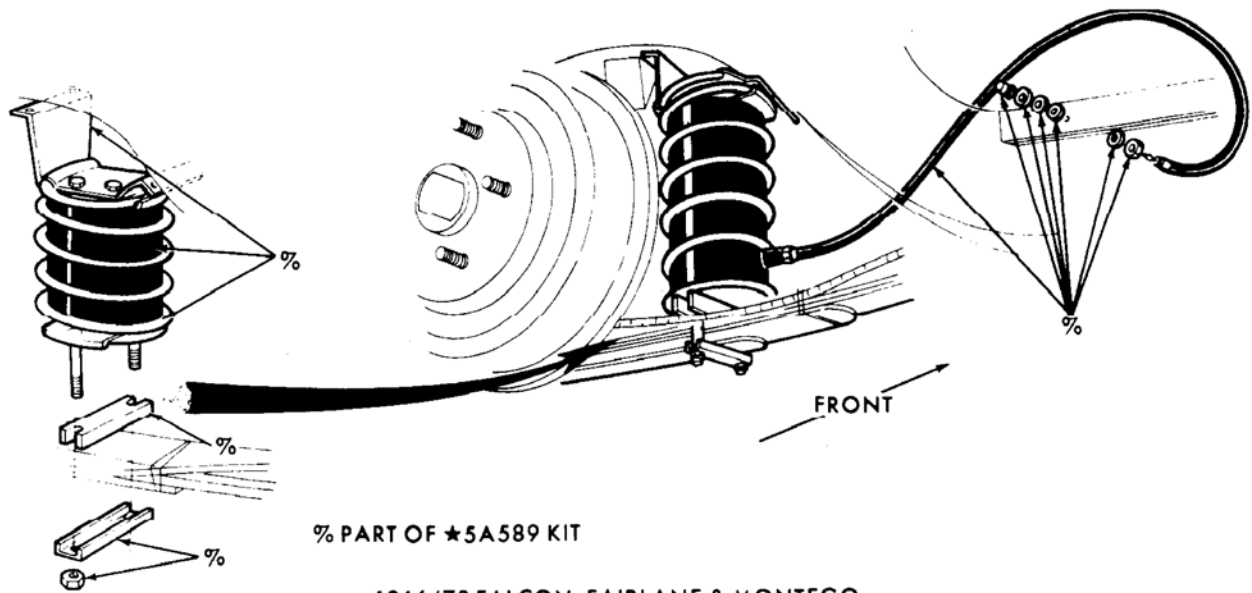

% PART OF ★5A589 KIT

1966/70 FALCON, FAIRLANE & MONTEGO -
BODY TYPE 71

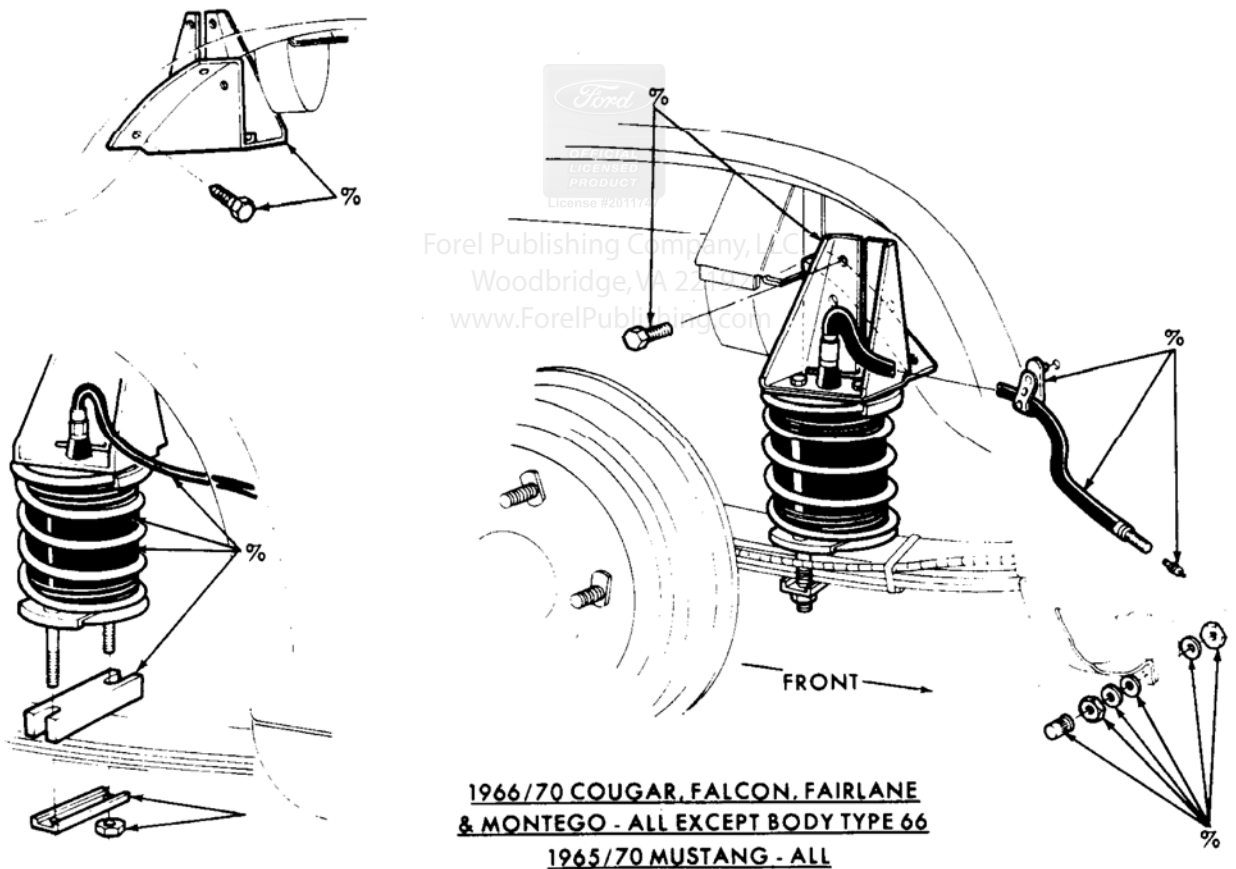

1966/70 COUGAR, FALCON, FAIRLANE
& MONTEGO - ALL EXCEPT BODY TYPE 66
1965/70 MUSTANG - ALL

% PART OF ★5A589 KIT

P-10675

REAR SUSPENSION (AUXILIARY AIR SPRING INSTALLATION)
1966 / 68 FALCON, 1966 / 70 FAIRLANE/TORINO AND 1965 / 70 MUSTANG

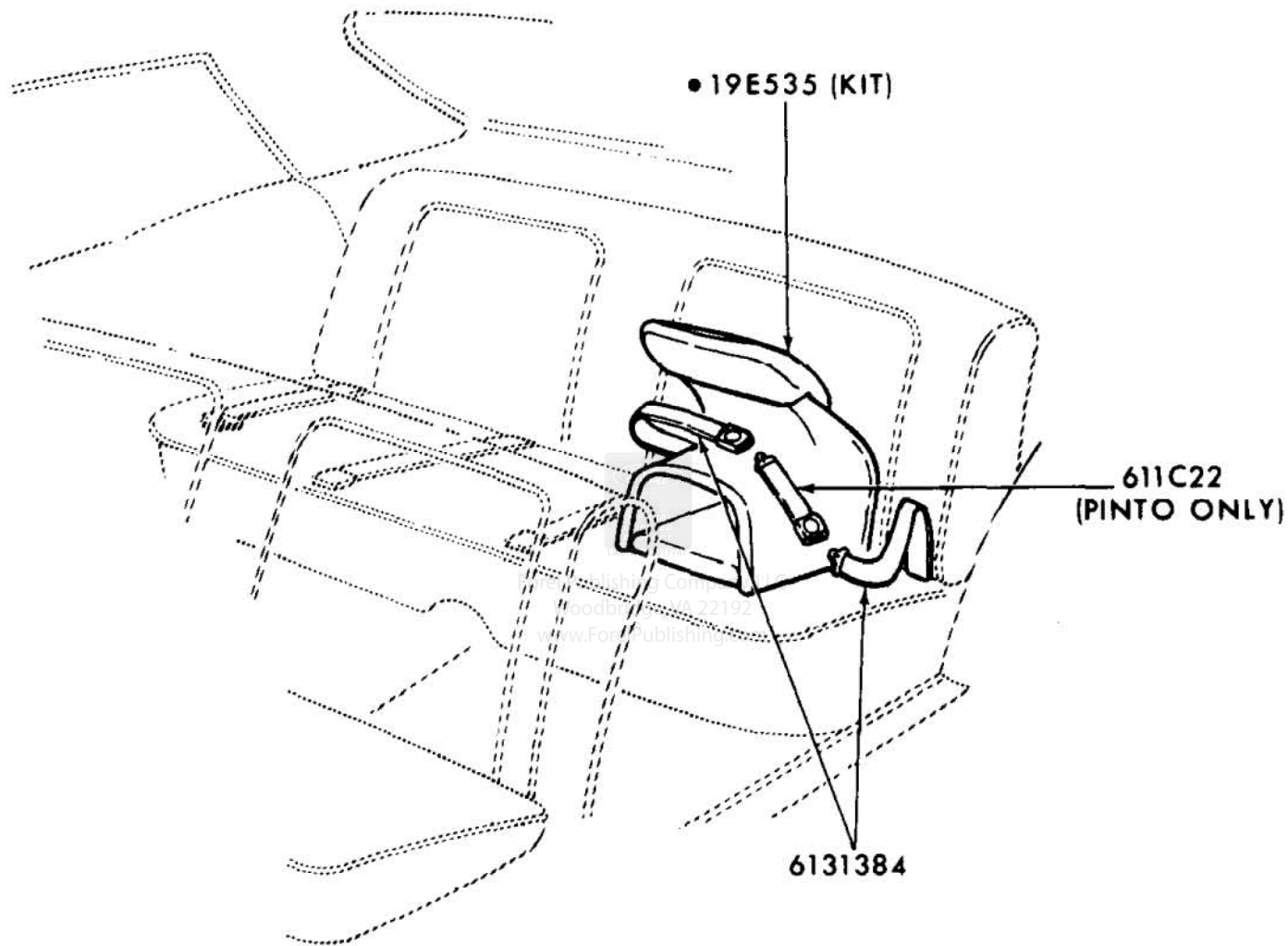

• REFER TO CHASSIS SECTION

P-11536

CHILD SAFETY SEAT
1965 / 72 ALL

**1965 MUSTANG—8 CYL. 289-4B PREMIUM FUEL &
8 CYL. 260-2B, 289-2B REGULAR FUEL**

CONSOLIDATED SERVICE REPLACEMENT (REPLACES ORIGINAL SERVICE SYSTEM BELOW)

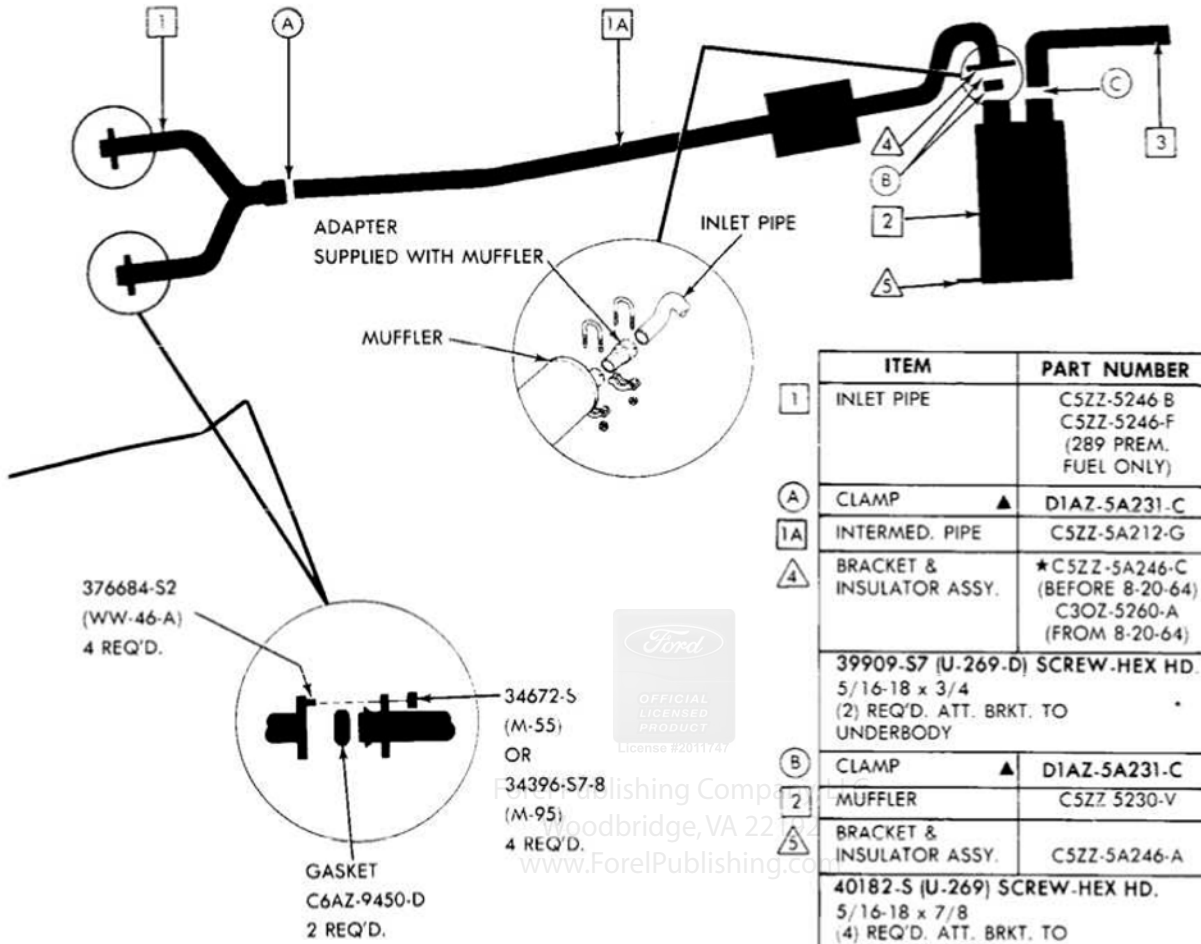

Original equipment muffler and outlet pipe are a welded assembly. To service this assembly you must replace it with both parts (muffler and outlet pipe) used together.

ORIGINAL SERVICE SYSTEM (REPLACED BY CONSOLIDATED SYSTEM ABOVE)

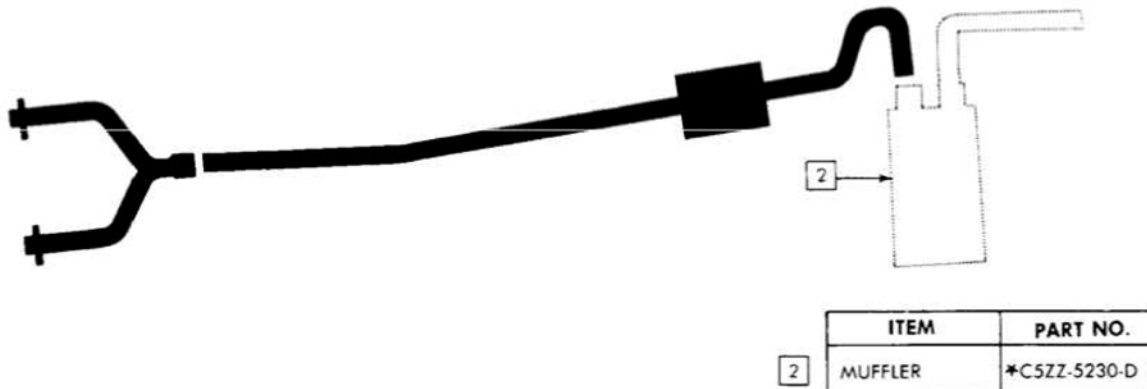

1965 MUSTANG—6 CYL. 170-1B & 200-1B

CONSOLIDATED SERVICE REPLACEMENT (REPLACES ORIGINAL SERVICE SYSTEM BELOW)

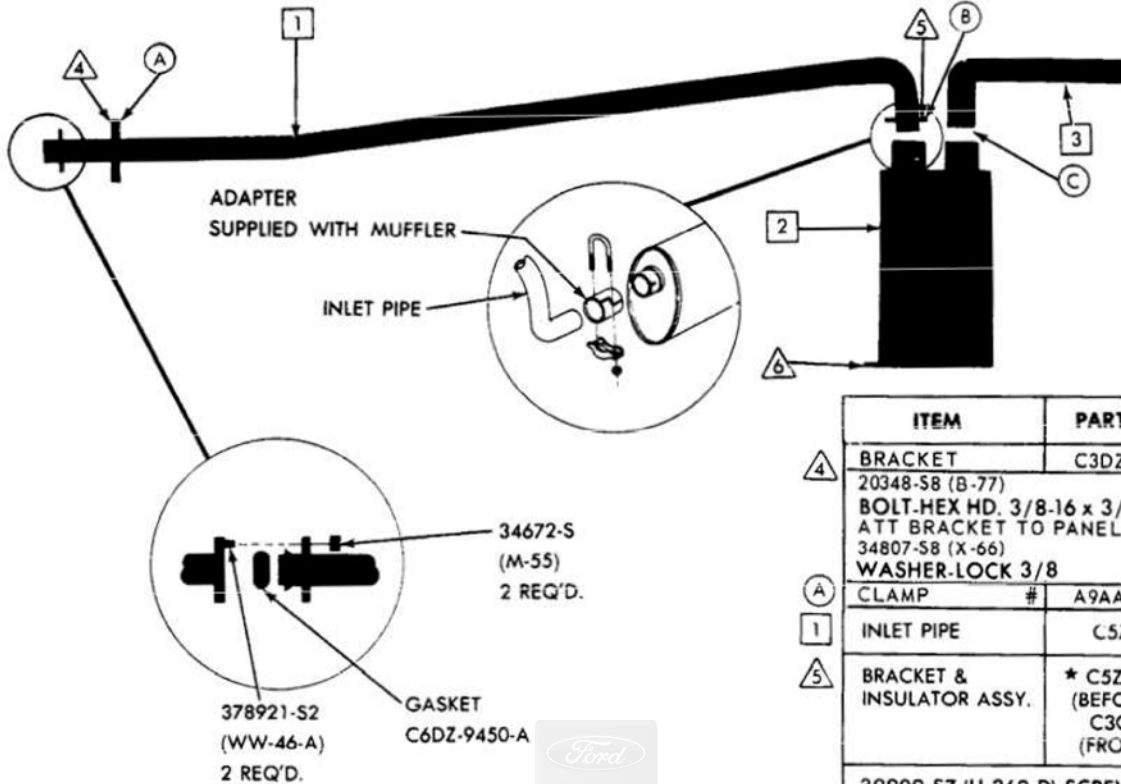

ITEM	PART NUMBER
C	CLAMP ▲ A9AA-5A231-B
3	OUTLET PIPE C5ZZ-5255-G

Original equipment muffler and outlet pipe are a welded assembly. To service this assembly you must replace it with both parts (muffler and outlet pipe) used together.

ITEM	PART NUMBER
4	BRACKET 20348-S8 (B-77) BOLT-HEX HD. 3/8-16 x 3/4 ATT BRACKET TO PANEL 34807-S8 (X-66) WASHER-LOCK 3/8
A	CLAMP # A9AA-5A231-A
1	INLET PIPE C5ZZ-5246-D
5	BRACKET & INSULATOR ASSY. * C5ZZ-5A246-C (BEFORE 8-20-64) C3OZ-5260-A (FROM 8-20-64)
	39909-S7 (U-269-D) SCREW - HEX HD. 5/16-18 x 3/4 (2) REQ'D. ATT. BRKT. TO UNDERBODY
B	CLAMP ▲ A9AA-5A231-B
2	MUFFLER KIT C5ZZ-5230-V
6	BRACKET & INSULATOR ASSY. C5ZZ-5A246-A
	40182-S (U-269) SCREW - HEX HD. 5/16-18 x 7/8 (4) REQ'D. ATT. BRKT. TO MUFFLER & BODY

ORIGINAL SERVICE SYSTEM (REPLACED BY CONSOLIDATED SYSTEM ABOVE)



ITEM	PART NUMBER
A	CLAMP # A9AA-5A231-A
2	MUFFLER *C5ZZ-5230-T

E-A-22

1965 MUSTANG—8 CYL. 289-4B GT & 289-4B SPECIAL (FROM 10-15-64)
INCLUDES SHELBY GT 350 & MODELS W/DUAL EXHAUST KIT - *

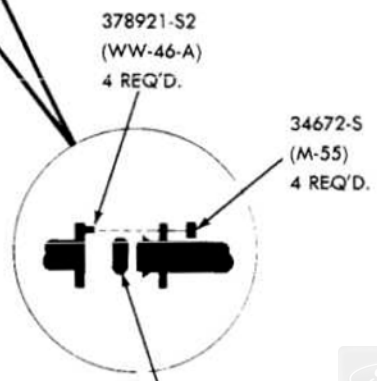
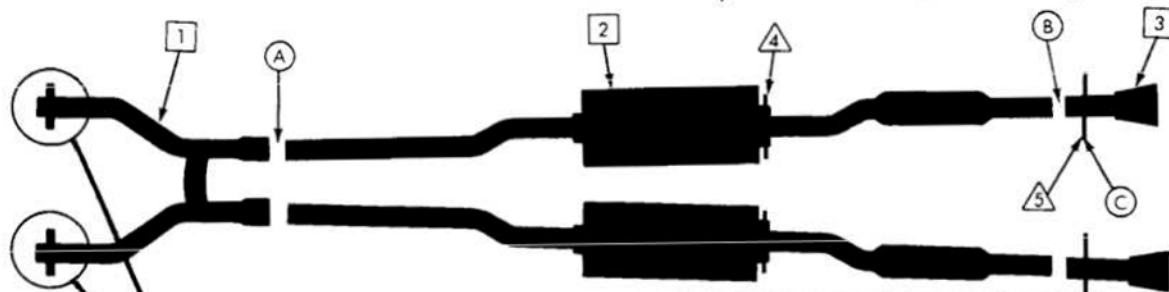

- C6AZ-9450-D GASKET (EXC. SHELBY)
- * S1MS-5260-A3A HEADER-TO-FLG. GASKET (SHELBY GT 350)
- * S1MS-5260-A1A HEADER-TO-ENG. GASKET (SHELBY GT 350) (2) REQ'D.
- * S1MS-5260-A2A HEADER-TO-ENG. BOLT (SHELBY GT 350)
- R/B 56138-S4 (8319V) (16) REQ'D.

ITEM	L.H.	R.H.
1 INLET PIPE	C5ZZ-5246-J (GT) C5ZZ-5246-K (SPECIAL) * S2MS-5246-A (SHELBY GT 350)	
A CLAMP	▲ D1AZ-5A231-C	D1AZ-5A231-C
2 MUFFLER	C6ZZ-5230-F (EXC. DUAL KIT) C5ZZ-5230-U (DUAL KIT)	C6ZZ-5230-E (EXC. DUAL KIT) C5ZZ-5230-U (DUAL KIT)
4 BRACKET & INSULATOR ASSY.	C3OZ-5260-A	C3OZ-5260-A
C1VV-5B236-C PLATE ASSY. (2) REQ'D. (BEFORE 3-30-65) 51765-S8 (U-370) SCREW-PAN HD.#10-24 x 1/2 (2) REQ'D. ATT. PLATE TO FLOOR PAN 373403-S8 (MM-173-J) NUT-HEX 3/8-16 (4) REQ'D. ATT. BRKT. TO MUFFLER C1VV-5B236-C PLATE ASSY. (2) REQ'D. (FROM 3-30-65) 51765-S8 (U-370) SCREW-HEX HD.#10-24 x 1/2 (2) REQ'D. ATT. PLATE TO FLOOR PAN 373403-S8 (MM-173-J) NUT-HEX 3/8-16 (4) REQ'D. ATT. BRKT. TO PLATE 351945-S2 (UU-52-J) SCREW-HEX HD.5/16-18 x 1-1/2 (4) REQ'D. ATT. BRKT. TO MUFFLER		
B CLAMP	C5ZZ-5A231-B	C5ZZ-5A231-B
PIPE MOULDING	C5ZZ-5C299-A (GT or PERF. IMAGE)	C5ZZ-5C299-A (GT or PERF. IMAGE)
5 BRACKET & INSULATOR ASSY.	C3DZ-5260-A (Before 3/22/65) C5ZZ-5277-A (From 3/22/65) C5ZZ-5260-F (From 3/22/65) C5ZZ-5277-A (From 3/22/65)	C3DZ-5260-A (Before 3/22/65) C5ZZ-5277-B (From 3/22/65) C5ZZ-5260-F (From 3/22/65) C5ZZ-5277-B (From 3/22/65)
23575-S8 (B-13) BOLT-HEX HD. 3/8-16 x 3 (4 REQ'D) ATT BRKT 5277 TO UNDERBODY 40182-S (U269) SCREW-HEX HD.5/16-18 x 7/8 (2 REQ'D) ATT 5260 TO 5277 373403-S8 (MM-173-J) NUT-HEX 3/8-16-16 (4 REQ'D) ATT BRKT TO UNDERBODY		
C CLAMP	C5ZZ-5A231-A	C5ZZ-5A231-A
3 PIPE EXTENSION	C5ZZ-5255-F (SPECIAL) C5ZZ-5255-D (GT or PERF. IMAGE)	C5ZZ-5255-F (SPECIAL) C5ZZ-5255-C (GT or PERF. IMAGE)

* - MUFFLER ONLY - OTHER PARTS OF 5210 KIT NOT SERVICED
 E-A-27

▲ Use D1AZ 5A231-C in U.S. only; use C000 5253-E in Canada

**1965 MUSTANG-8 CYL. 289-4B SPECIAL (BEFORE 10-15-64)-TRANSVERSE MUFFLER
(INCLUDES SHELBY GT-350)**

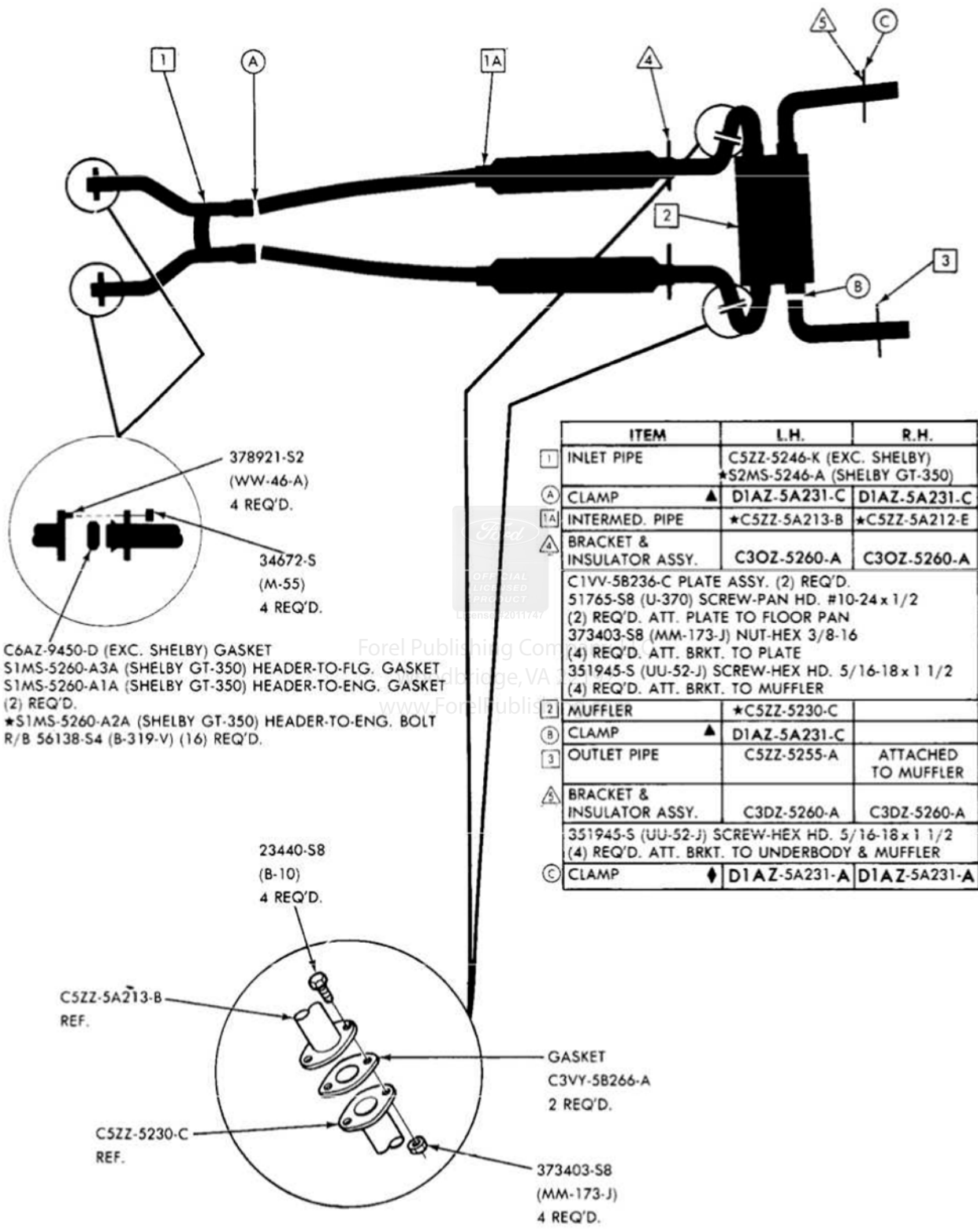

378921-S2
(WW-46-A)
4 REQ'D.

34672-S
(M-55)
4 REQ'D.

C6AZ-9450-D (EXC. SHELBY) GASKET
 *S1MS-5260-A3A (SHELBY GT-350) HEADER-TO-FLG. GASKET
 *S1MS-5260-A1A (SHELBY GT-350) HEADER-TO-ENG. GASKET (2) REQ'D.
 *S1MS-5260-A2A (SHELBY GT-350) HEADER-TO-ENG. BOLT R/B 56138-S4 (B-319-V) (16) REQ'D.

23440-S8
(B-10)
4 REQ'D.

C5ZZ-5A213-B
REF.

C5ZZ-5230-C
REF.

GASKET
C3VY-5B266-A
2 REQ'D.

373403-S8
(MM-173-J)
4 REQ'D.

ITEM	L.H.	R.H.
1 INLET PIPE	C5ZZ-5246-K (EXC. SHELBY) *S2MS-5246-A (SHELBY GT-350)	
A CLAMP	▲ DIAZ-5A231-C	DIAZ-5A231-C
1A INTERMED. PIPE	*C5ZZ-5A213-B	*C5ZZ-5A212-E
4 BRACKET & INSULATOR ASSY.	C3OZ-5260-A	C3OZ-5260-A
C1VV-5B236-C PLATE ASSY. (2) REQ'D. 51765-S8 (U-370) SCREW-PAN HD. #10-24 x 1/2 (2) REQ'D. ATT. PLATE TO FLOOR PAN 373403-S8 (MM-173-J) NUT-HEX 3/8-16 (4) REQ'D. ATT. BRKT. TO PLATE 351945-S (UU-52-J) SCREW-HEX HD. 5/16-18 x 1 1/2 (4) REQ'D. ATT. BRKT. TO MUFFLER		
2 MUFFLER	*C5ZZ-5230-C	
B CLAMP	▲ DIAZ-5A231-C	
3 OUTLET PIPE	C5ZZ-5255-A	ATTACHED TO MUFFLER
4 BRACKET & INSULATOR ASSY.	C3DZ-5260-A	C3DZ-5260-A
351945-S (UU-52-J) SCREW-HEX HD. 5/16-18 x 1 1/2 (4) REQ'D. ATT. BRKT. TO UNDERBODY & MUFFLER		
C CLAMP	◆ DIAZ-5A231-A	DIAZ-5A231-A

▲ Use DIAZ 5A231-C in U.S. only; use C000 5253-E in Canada
 ◆ Use DIAZ-5A231-A in U.S. only; use C000-5253-F in Canada

1965 MUSTANG—8 CYL. 289-4B SPECIAL
(BEFORE 10-15-64)—INLINE MUFFLER

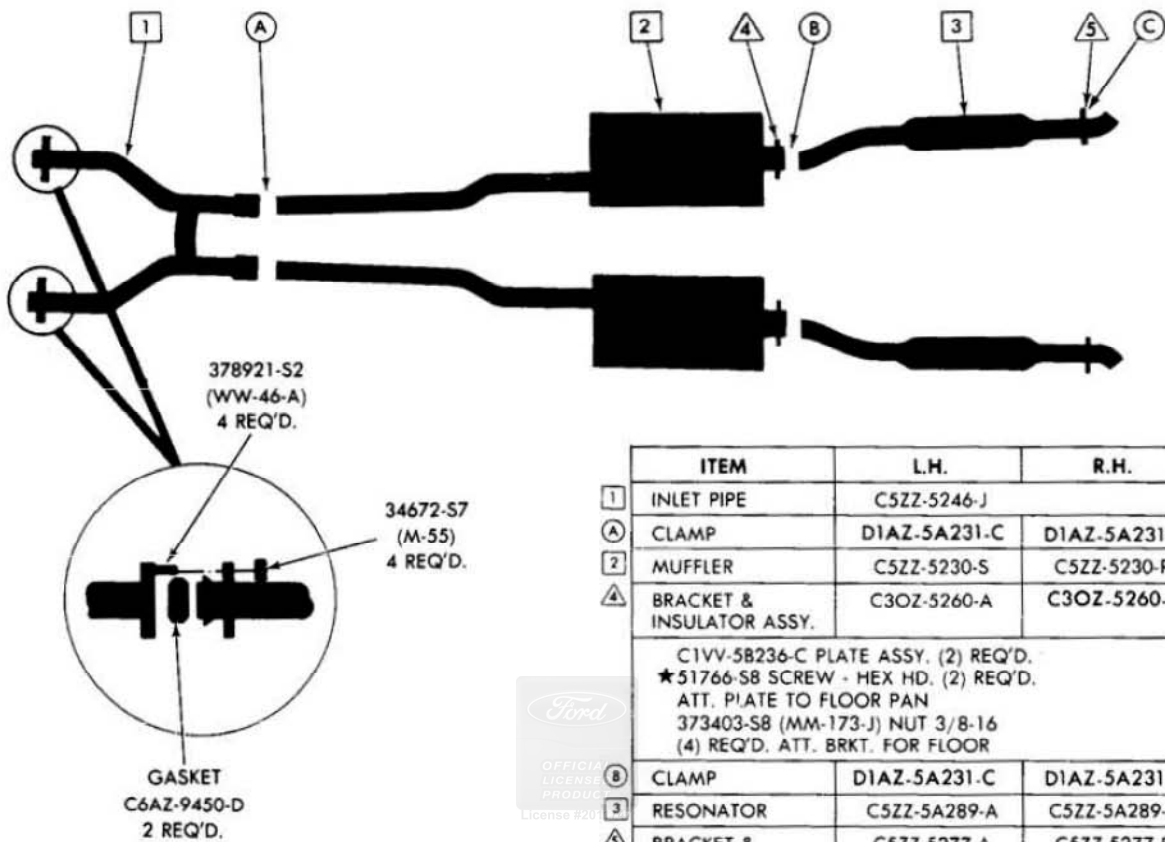

ITEM	L.H.	R.H.
1	C5ZZ-5246-J	
A	D1AZ-5A231-C	D1AZ-5A231-C
2	C5ZZ-5230-S	C5ZZ-5230-R
▲	C3OZ-5260-A	C3OZ-5260-A
C1VV-5B236-C PLATE ASSY. (2) REQ'D. ★ 51766-S8 SCREW - HEX HD. (2) REQ'D. ATT. PLATE TO FLOOR PAN 373403-S8 (MM-173-J) NUT 3/8-16 (4) REQ'D. ATT. BRKT. FOR FLOOR		
B	D1AZ-5A231-C	D1AZ-5A231-C
3	C5ZZ-5A289-A	C5ZZ-5A289-B
▲	C5ZZ-5277-A C5ZZ-5260-F C5ZZ-5266-B	C5ZZ-5277-B C5ZZ-5260-F C5ZZ-5266-B
C	D1AZ-5A231-C	D1AZ-5A231-C
39909-S7 (U-269-D) SCREW - HEX HD. 5/16-18 x 3/4 (2) REQ'D. ATT. BRKT. TO UNDERBODY		

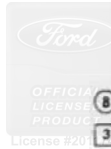

Forel Publishing Co.
Woodbridge, Vt. 02197
www.ForelPubl.com

This number, like the other numbers on the illustrations, is the **basic** part number and can be used to help identify the correct service part.

The basic part number is generally part of the complete part number. For example, highlighted in **bold** type is the basic part number as part of the complete part number:

C4DZ- 2211 -C	1965 Mustang (9" x 1 1/2" brakes)
C4DZ- 2211 -B	1965 Mustang (9" x 2 1/4" brakes)
C6OZ- 2211 -D	1965/69 Mustang (10" x 1 3/4" brakes), Before 8/12/68
C6DZ- 2211 -A	1966/70 Mustang (9" x 1 1/2" brakes)
C6OZ- 2211 -A	1969 Mustang (10" x 2" brakes), Before 8/12/68

How to Read Chassis and Body Part Numbers:

Chassis parts and Body parts have two different formats, so it is important to understand the differences.

Chassis Part Numbers:

Chassis Parts have a four character prefix, a four or five digit **basic part number**, and a one-letter suffix. The first two numbers of the basic part number identify the section. Chassis part numbers range from 1001 to 19A998

Example: C5ZZ-5255-F
(Exhaust "turn-down" tailpipe on '65-66 289 4V Non-GT Mustangs)

First digit: Decade

The first digit is a character entry relating to the decade of production.

A =1940's (often omitted)		D =1970's
B =1950'		E =1980's
C =1960's		F =1990's

Second digit: Year

The second digit is the last digit of the year of part introduction or revision.

5 =1965		9=1969
6 =1966		0=1970
7 =1967		1=1971
8 =1968		2=1972

The third digit is the model application. For example a part with a model code of B would generally apply to Bronco's. However, there are numerous examples where the model code is actually used for different models. For example, some of the Mustang Boss 429 parts have a C9AE prefix which corresponds to a 1969 generic Ford car or Galaxie.

Code	Description	Code	Description
A	Ford (Generic) / Galaxie	R	Rotunda (Generic)(1962-69) Ford of Europe (1970-up)
B	Bronco (1970-73)	S	Thunderbird
C	Remanufactured Parts (1966-75)	T	Bronco (1966-82, Except 1970-73)
D	Falcon (1960-69) Maverick (1970-74)	U	Econoline/Club Wagon Van
E	Truck (Cab over Engine) (1970-73)	V	Lincoln
F	Foreign / Trans Am Racing	W	Cougar (1967-80)
G	Comet (1961-67) Montego (1968-76)	X	Truck (Short Highway) (1970-73)
H	Holman/Moody HiPo Part	Y	Meteor (Canada) (1962-72)
J	Industrial	Z	Mustang
K	Tilt Cab (1970-73)	2	Pinto (1972-75)
L	Lincoln	4	Comet (1971-74)
M	Mercury	6	Pantera (1971-75) Topaz (1984-up)
N	Tractor	7	Courier (1971-82)
O	Fairlane Torino (1969-76)	8	Capri (U.S. Parts) (1972-75)
P	Autolite (Later Motorcraft)	9	Turbine Engine Parts (1970-75)

Fourth digit: Design Engineer Office

The fourth digit is the design engineering office. The design office, as the name implies, was the office responsible for the design of the part. Some of the more common codes are: B=body, C=chassis and E=engine.

Code	Design Engineering Office
A	Light Truck Engineering Division
B	Body and Electrical Product Division
C	Chassis
D	Overseas Product Engineering
E	Engine
F	General Parts/Electrical and Electronics Division
H	Climate Control

J	Autolite/Ford Parts & Service Division
L	Industrial Engine Parts & Service
M	Performance/Special Vehicle Operations
N	Tractor Parts
P	Auto Transmission
R	Manual Transmission
S	Light and Heavy Truck Special Order Parts
T	Heavy Truck Engineering
U	Special Vehicle Operations
W	Axle and Driveshaft
X	Emissions, Economy and Special Vehicle Engineering (also known as Special Vehicle Engineering)
Y	Lincoln/Mercury Service Parts
Z	Ford Service Parts

Fifth thru Eighth (or ninth, or tenth) digit: Group Number

(also referred to as the *Basic Part Number*)

The fifth thru perhaps the tenth digit is the Group Number or the Basic Part Number.

Example (Group numbered **bolded** for emphasis):

C5ZZ-**5255**-F

C8TZ-**1A401**-A (with an expanded basic part number)

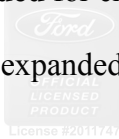

Last Digit or Suffix

The last digit is usually a letter (A, B, C, etc.) and indicates a revision or change to a particular part. If the part did not change, the suffix is not used. The letter A=the first change, B=second change, etc.

Body Part Numbers:

Body part numbers are similar to Chassis part numbers with the first four characters using the same format as the chassis part number (see Chassis Part Numbers above). However, the group number or basic part number uses a seven digit number. The first two digits identify the body type and the last five numbers ("Body Group") identify the specific part within a general body area. A one to three-letter suffix may be used, usually to indicate color. For example,

Example #1: **D0DZ-6200052-A**

Body Type Code = 62 (Falcon, 2 door sedan)

Group Number = 00052 (Vehicle Identification Retainer)

Example#2: **C6ZZ-6504290-BAB**

Body Type Code = 65 (Mustang, 2 door hardtop)

Group Number = 04290 (Instrument Panel,
Black)

Engineering or Casting Numbers

Service Part numbers differ from Engineering or Casting numbers. Part numbers were used for servicing, ordering and inventory purposes and were marked on parts boxes, tags, and labels attached to the part. Engineering or casting numbers were normally stamped or cast into the part itself for identification during the manufacturing process. Engineering or Casting numbers are *not* interchangeable with Service Part Numbers. The Ford Car Master Parts and Accessory Catalog contains Service Part Numbers but does provide some cross references to engineering numbers. A service part may differ from a part installed during the production of a vehicle, however, the service part is what Ford would use to repair or replace it during servicing.

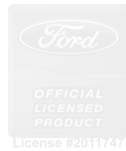

Forel Publishing Company, LLC
Woodbridge, VA 22192
www.ForelPublishing.com